

MOTOR DATA @ 460 VAC (TRAP)

MOTOR PARAMETERS	UNITS	VALUE
HORSEPOWER	HP RATED	2.1
KILOWATTS	KW RATED	1.6
MAX. OPERATING SPEED	N MAX	4200
MAX. OPERATING TORQUE	RPM	3000
* CONTINUOUS RATED TORQUE @ 3000 RPM	N RATED	45.0 [5.1]
* CONTINUOUS STALL TORQUE	IN-LBS [Nm]	54.0 [6.1]
CONTINUOUS LINE CURRENT	AMPS	4.4
PEAK TORQUE	IN-LBS [Nm]	189.1 [21.3]
PEAK CURRENT	AMPS	15.3
MAX. THEORETICAL ACCEL.	RAD/SEC ²	54,029
TORQUE SENSITIVITY	Kt IN-LBS/AMP [Nm/AMP]	12.4 [1.42]
BACK EMF (LINE TO LINE)	Vrms/Krpm	110.0
D.C. RESISTANCE (P-P)	OHMS	3.2
INDUCTANCE (P-P)	MILLIHENRIES	24.0
ROTOR INERTIA	Jm [IN-LBS-SEC ²] [Kg-M ²]	0.0035 [0.00039]
STATIC FRICTION	Tf [IN-LBS] [Nm]	1.0 [0.11]

*25°C AMBIENT WITH A MAXIMUM CASE TEMPERATURE OF 100°C ON MOTOR. MOTOR MOUNTED ON A 12" X 12" X 1/2" ALUMINUM HEATSINK. THERMOSTAT IN STATOR WINDINGS WILL OPEN IF WINDING TEMPERATURE EXCEEDS 155°C. THIS ALLOWS FOR AN APPROXIMATE +10% HEADROOM IN THE CONTINUOUS TORQUE RATING BEFORE THERMOSTAT OPENS.

MECHANICAL NOTES:

1. AXIAL LOAD: 50 LBS MAX
2. RADIAL LOAD: 100 LBS MAX @ 1" FROM FACE
3. MOTOR SEALED TO IP65.
4. MOTOR WEIGHT: 18 LBS. [8.2 kg]
5. MOTOR FINISH: BLACK EPOXY
6. MOTOR OUTPUT SHAFT: STAINLESS STEEL
7. MILLIMETERS (INCHES)

CONNECTION CHART

MOTOR CONNECTOR:
PT02E-14-5P(027)
(270-00026)

MOTOR WIRE LEADS	WIRE FUNCTION	WIRE COLOR
A	ΦR	RED
B	ΦS	BLACK
C	ΦT	BLUE
D	PE GND	GRN/YEL
E	-	-

RESOLVER/THERM CONNECTOR:

PT02E-14-18P(027)
(270-00024)

MOTOR WIRE LEADS	RES/THERM WIRE LEADS
A	U
B	N
C	H
D	G
E	S
F	F
R	R
E	E
D	D
P	P
A	A
B	B
C	C
J	J
K	K
L	L
M	M
T	T

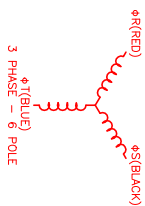
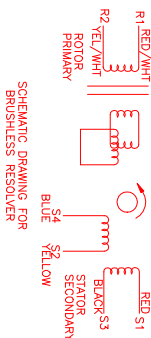
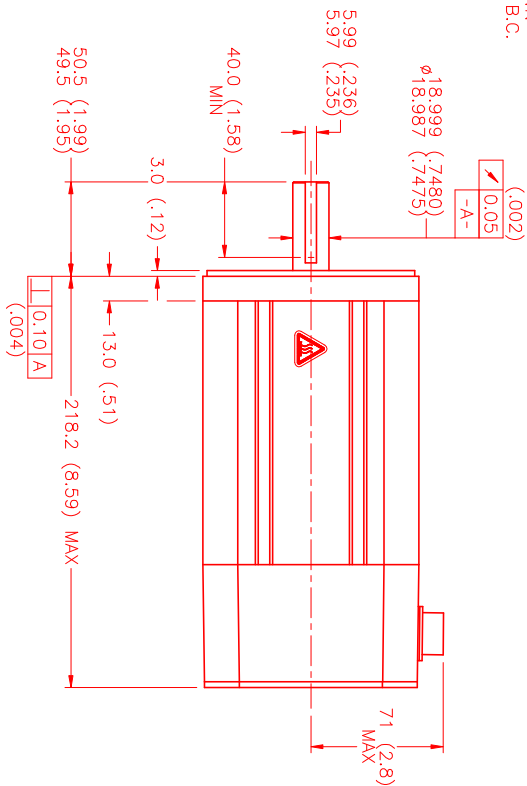
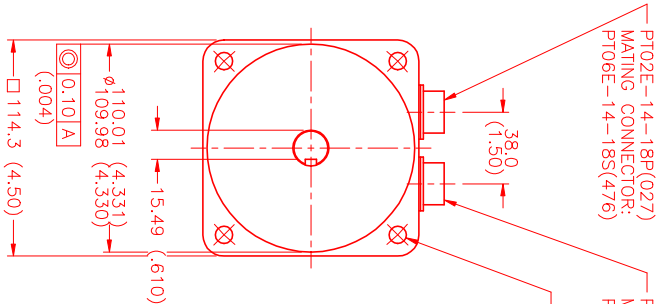

REV.	DESCRIPTION	DATE	APPD.
1	PRELIMINARY	2/10/00	LIN

NO.	PART NUMBER	DESCRIPTION	QTY.
1	MPM1141CTUG1N	RESOLVER/THERM CONNECTOR	1

NO.	PART NUMBER	DESCRIPTION	QTY.
1	MPM1141CTUG1N	RESOLVER/THERM CONNECTOR	1

NO.	PART NUMBER	DESCRIPTION	QTY.
1	MPM1141CTUG1N	RESOLVER/THERM CONNECTOR	1

NO.	PART NUMBER	DESCRIPTION	QTY.
1	MPM1141CTUG1N	RESOLVER/THERM CONNECTOR	1

NO.	PART NUMBER	DESCRIPTION	QTY.
1	MPM1141CTUG1N	RESOLVER/THERM CONNECTOR	1

NO.	PART NUMBER	DESCRIPTION	QTY.
1	MPM1141CTUG1N	RESOLVER/THERM CONNECTOR	1

NO.	PART NUMBER	DESCRIPTION	QTY.
1	MPM1141CTUG1N	RESOLVER/THERM CONNECTOR	1

NO.	PART NUMBER	DESCRIPTION	QTY.
1	MPM1141CTUG1N	RESOLVER/THERM CONNECTOR	1

NO.	PART NUMBER	DESCRIPTION	QTY.
1	MPM1141CTUG1N	RESOLVER/THERM CONNECTOR	1

NO.	PART NUMBER	DESCRIPTION	QTY.
1	MPM1141CTUG1N	RESOLVER/THERM CONNECTOR	1

NO.	PART NUMBER	DESCRIPTION	QTY.
1	MPM1141CTUG1N	RESOLVER/THERM CONNECTOR	1

NO.	PART NUMBER	DESCRIPTION	QTY.
1	MPM1141CTUG1N	RESOLVER/THERM CONNECTOR	1

NO.	PART NUMBER	DESCRIPTION	QTY.
1	MPM1141CTUG1N	RESOLVER/THERM CONNECTOR	1

NO.	PART NUMBER	DESCRIPTION	QTY.
1	MPM1141CTUG1N	RESOLVER/THERM CONNECTOR	1

NO.	PART NUMBER	DESCRIPTION	QTY.
1	MPM1141CTUG1N	RESOLVER/THERM CONNECTOR	1

NO.	PART NUMBER	DESCRIPTION	QTY.
1	MPM1141CTUG1N	RESOLVER/THERM CONNECTOR	1

NO.	PART NUMBER	DESCRIPTION	QTY.
1	MPM1141CTUG1N	RESOLVER/THERM CONNECTOR	1

NO.	PART NUMBER	DESCRIPTION	QTY.
1	MPM1141CTUG1N	RESOLVER/THERM CONNECTOR	1

NO.	PART NUMBER	DESCRIPTION	QTY.
1	MPM1141CTUG1N	RESOLVER/THERM CONNECTOR	1

NO.	PART NUMBER	DESCRIPTION	QTY.
1	MPM1141CTUG1N	RESOLVER/THERM CONNECTOR	1

NO.	PART NUMBER	DESCRIPTION	QTY.
1	MPM1141CTUG1N	RESOLVER/THERM CONNECTOR	1

NO.	PART NUMBER	DESCRIPTION	QTY.
1	MPM1141CTUG1N	RESOLVER/THERM CONNECTOR	1

NO.	PART NUMBER	DESCRIPTION	QTY.
1	MPM1141CTUG1N	RESOLVER/THERM CONNECTOR	1

NO.	PART NUMBER	DESCRIPTION	QTY.
1	MPM1141CTUG1N	RESOLVER/THERM CONNECTOR	1

NO.	PART NUMBER	DESCRIPTION	QTY.
1	MPM1141CTUG1N	RESOLVER/THERM CONNECTOR	1

NO.	PART NUMBER	DESCRIPTION	QTY.
1	MPM1141CTUG1N	RESOLVER/THERM CONNECTOR	1

NO.	PART NUMBER	DESCRIPTION	QTY.
1	MPM1141CTUG1N	RESOLVER/THERM CONNECTOR	1

NO.	PART NUMBER	DESCRIPTION	QTY.
1	MPM1141CTUG1N	RESOLVER/THERM CONNECTOR	1

NO.	PART NUMBER	DESCRIPTION	QTY.
1	MPM1141CTUG1N	RESOLVER/THERM CONNECTOR	1

NO.	PART NUMBER	DESCRIPTION	QTY.
1	MPM1141CTUG1N	RESOLVER/THERM CONNECTOR	1

NO.	PART NUMBER	DESCRIPTION	QTY.
1	MPM1141CTUG1N	RESOLVER/THERM CONNECTOR	1

NO.	PART NUMBER	DESCRIPTION	QTY.
1	MPM1141CTUG1N	RESOLVER/THERM CONNECTOR	1

NO.	PART NUMBER	DESCRIPTION	QTY.
1	MPM1141CTUG1N	RESOLVER/THERM CONNECTOR	1

NO.	PART NUMBER	DESCRIPTION	QTY.
1	MPM1141CTUG1N	RESOLVER/THERM CONNECTOR	1

NO.	PART NUMBER	DESCRIPTION	QTY.
1	MPM1141CTUG1N	RESOLVER/THERM CONNECTOR	1

NO.	PART NUMBER	DESCRIPTION	QTY.
1	MPM1141CTUG1N	RESOLVER/THERM CONNECTOR	1

NO.	PART NUMBER	DESCRIPTION	QTY.
1	MPM1141CTUG1N	RESOLVER/THERM CONNECTOR	1

NO.	PART NUMBER	DESCRIPTION	QTY.
1	MPM1141CTUG1N	RESOLVER/THERM CONNECTOR	1

NO.	PART NUMBER	DESCRIPTION	QTY.
1	MPM1141CTUG1N	RESOLVER/THERM CONNECTOR	1

NO.	PART NUMBER	DESCRIPTION	QTY.
1	MPM1141CTUG1N	RESOLVER/THERM CONNECTOR	1

NO.	PART NUMBER	DESCRIPTION	QTY.
1	MPM1141CTUG1N	RESOLVER/THERM CONNECTOR	1

NO.	PART NUMBER	DESCRIPTION	QTY.
1	MPM1141CTUG1N	RESOLVER/THERM CONNECTOR	1

NO.	PART NUMBER	DESCRIPTION	QTY.
1	MPM1141CTUG1N	RESOLVER/THERM CONNECTOR	1

NO.	PART NUMBER	DESCRIPTION	QTY.
1	MPM1141CTUG1N	RESOLVER/THERM CONNECTOR	1

NO.	PART NUMBER	DESCRIPTION	QTY.
1	MPM1141CTUG1N	RESOLVER/THERM CONNECTOR	1

NO.	PART NUMBER	DESCRIPTION	QTY.
1	MPM1141CTUG1N	RESOLVER/THERM CONNECTOR	1

NO.	PART NUMBER	DESCRIPTION	QTY.
1	MPM1141CTUG1N	RESOLVER/THERM CONNECTOR	1

NO.	PART NUMBER	DESCRIPTION	QTY.
1	MPM1141CTUG1N	RESOLVER/THERM CONNECTOR	1

NO.	PART NUMBER	DESCRIPTION	QTY.
1	MPM1141CTUG1N	RESOLVER/THERM CONNECTOR	1

NO.	PART NUMBER	DESCRIPTION	QTY.
1	MPM1141CTUG1N	RESOLVER/THERM CONNECTOR	1

NO.	PART NUMBER	DESCRIPTION	QTY.
1	MPM1141CTUG1N	RESOLVER/THERM CONNECTOR	1

NO.	PART NUMBER	DESCRIPTION	QTY.
1	MPM1141CTUG1N	RESOLVER/THERM CONNECTOR	1

NO.	PART NUMBER	DESCRIPTION	QTY.
1	MPM1141CTUG1N	RESOLVER/THERM CONNECTOR	1

NO.	PART NUMBER	DESCRIPTION	QTY.
1	MPM1141CTUG1N	RESOLVER/THERM CONNECTOR	1

NO.	PART NUMBER	DESCRIPTION	QTY.
1	MPM1141CTUG1N	RESOLVER/THERM CONNECTOR	1

NO.	PART NUMBER	DESCRIPTION	QTY.
1	MPM1141CTUG1N	RESOLVER/THERM CONNECTOR	1

NO.	PART NUMBER	DESCRIPTION	QTY.
1	MPM1141CTUG1N	RESOLVER/THERM CONNECTOR	1

NO.	PART NUMBER	DESCRIPTION	QTY.
1	MPM1141CTUG1N	RESOLVER/THERM CONNECTOR	1

NO.	PART NUMBER	DESCRIPTION	QTY.
1	MPM1141CTUG1N	RESOLVER/THERM CONNECTOR	1

NO.	PART NUMBER	DESCRIPTION	QTY.
1	MPM1141CTUG1N	RESOLVER/THERM CONNECTOR	1

NO.	PART NUMBER	DESCRIPTION	QTY.
1	MPM1141CTUG1N	RESOLVER/THERM CONNECTOR	1

NO.	PART NUMBER	DESCRIPTION	QTY.
1	MPM1141CTUG1N	RESOLVER/THERM CONNECTOR	1

NO.	PART NUMBER	DESCRIPTION	QTY.
1	MPM1141CTUG1N	RESOLVER/THERM CONNECTOR	1

NO.	PART NUMBER	DESCRIPTION	QTY.
1	MPM1141CTUG1N	RESOLVER/THERM CONNECTOR	1

NO.	PART NUMBER	DESCRIPTION	QTY.
1	MPM1141CTUG1N	RESOLVER/THERM CONNECTOR	1

NO.	PART NUMBER	DESCRIPTION	QTY.
1	MPM1141CTUG1N		