

MOTOR DATA @ 230 VAC (TRAP)

| MOTOR PARAMETERS | UNITS | VALUE |
|--------------------------------------|--|---------------|
| HORSEPOWER | HP | 9.1 |
| KILOWATTS | KW | 6.8 |
| MAX. OPERATING SPEED | N MAX RPM | 2700 |
| SPEED @ RATED TORQUE | N RATED RPM | 2400 |
| * CONTINUOUS RATED TORQUE @ 2400 RPM | IN-LBS[Nm] | 238.0[26.9] |
| * CONTINUOUS STALL TORQUE | IN-LBS[Nm] | 280.0[31.5] |
| CONTINUOUS LINE CURRENT | AMPS | 35.4 |
| PEAK TORQUE | IN-LBS[Nm] | 840.0[94.4] |
| PEAK CURRENT | AMPS | 106.3 |
| MAX. THEORETICAL ACCEL. | RAD/SEC ² | 30.769 |
| TORQUE SENSITIVITY | Kt[IN-LBS/AMP][Nm/AMP] | 7.9[0.89] |
| BACK EMF (LINE TO LINE) | Vrms/Krpm | 70.0 |
| D.C. RESISTANCE (P-P) | OHMS | 0.13 |
| INDUCTANCE (P-P) | MILLIHENRIES | 1.4 |
| ROTOR INERTIA | Jm[IN-LBS-SEC ²][Kg-M ²] | .0273[.00308] |
| STATIC FRICTION | Tf[IN-LBS][Nm] | 3.6[0.40] |

CONNECTION CHART

| MOTOR WIRE LEADS | WIRE FUNCTION | WIRE COLOR |
|------------------|---------------|------------|
| 1 | ΦS | BLACK |
| 2 | ΦT | BLUE |
| 3 | PE GND | GRN/YEL |

| RES/THERM WIRE LEADS | WIRE FUNCTION | WIRE COLOR |
|----------------------|---------------|------------|
| S9 | REF GND | YEL/WHI |
| S8 | REF | RED/WHI |
| S7 | SIN | YELLOW |
| S6 | COS | RED |
| S5 | COS GND | BLACK |
| S4 | SIN GND | BLUE |
| S3 | THERM | BLACK |
| S2 | THERM | BLACK |
| S1 | RES SHLD | GRN/YEL |

*25°C AMBIENT WITH A MAXIMUM CASE TEMPERATURE OF 100°C ON MOTOR. MOTOR MOUNTED ON A 12" X 12" X 1/2" ALUMINUM HEATSINK. THERMOSTAT IN STATOR WINDINGS WILL OPEN IF WINDING TEMPERATURE EXCEEDS 155°C. THIS ALLOWS FOR AN APPROXIMATE +10% HEADROOM IN THE CONTINUOUS TORQUE RATING BEFORE THERMOSTAT OPENS.

MECHANICAL NOTES:

- AXIAL LOAD: 50 LBS MAX
- RADIAL LOAD: 150 LBS MAX @ 1" FROM FACE
- MOTOR SEALED TO IP65.
- MOTOR WEIGHT: 66 LBS. [29.9 Kg]
- MOTOR FINISH: BLACK EPOXY
- MOTOR OUTPUT SHAFT: STAINLESS STEEL
- MILLIMETERS (INCHES)

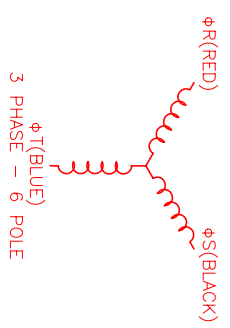
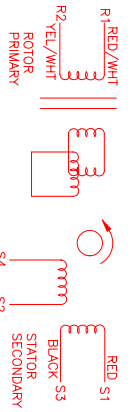
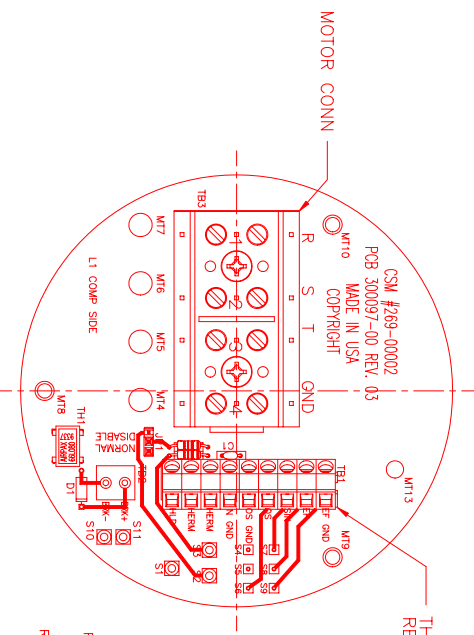
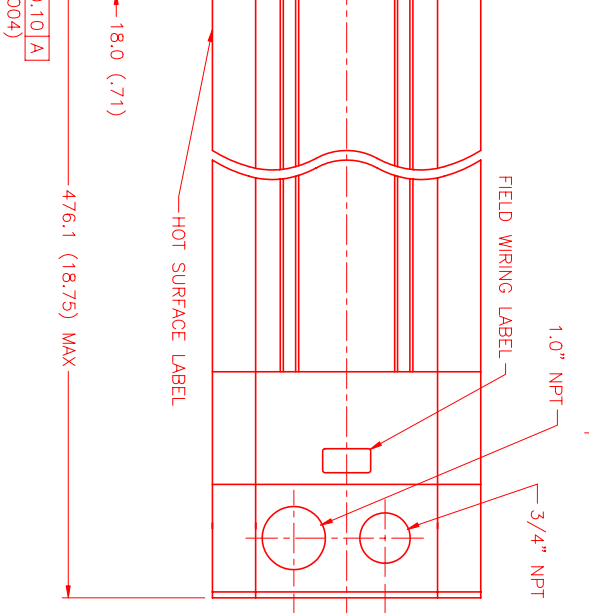
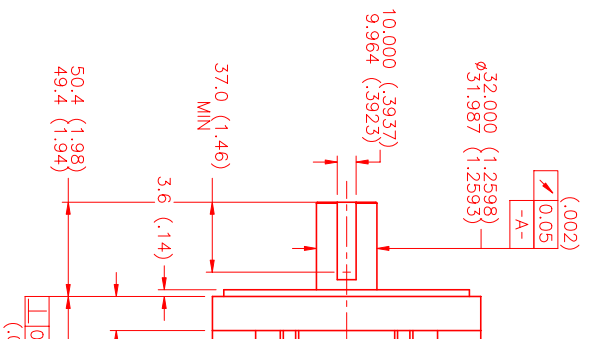
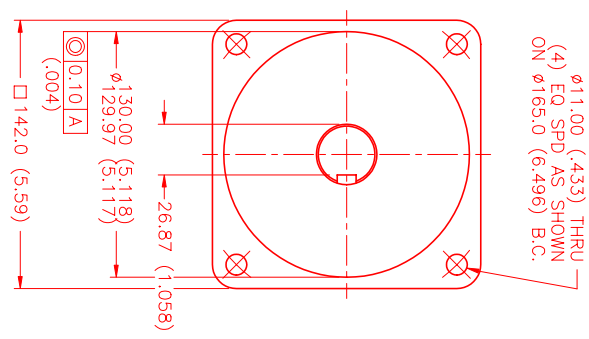

| NO. | PART NUMBER | DESCRIPTION | QTY. |
|-----|----------------|-------------|------|
| 1 | MPM1423ATG7G3N | MOTOR | 1 |

| REV. | DESCRIPTION | DATE | APPD. |
|-------------|-------------|---------|-------|
| PRELIMINARY | | 7/16/99 | EJS |

| NO. | PART NUMBER | DESCRIPTION | QTY. |
|-----|----------------|-------------|------|
| 1 | MPM1423ATG7G3N | MOTOR | 1 |

| REV. | DESCRIPTION | DATE | APPD. |
|-------------|-------------|---------|-------|
| PRELIMINARY | | 7/16/99 | EJS |

| NO. | PART NUMBER | DESCRIPTION | QTY. |
|-----|----------------|-------------|------|
| 1 | MPM1423ATG7G3N | MOTOR | 1 |

| REV. | DESCRIPTION | DATE | APPD. |
|-------------|-------------|---------|-------|
| PRELIMINARY | | 7/16/99 | EJS |

| NO. | PART NUMBER | DESCRIPTION | QTY. |
|-----|----------------|-------------|------|
| 1 | MPM1423ATG7G3N | MOTOR | 1 |

| REV. | DESCRIPTION | DATE | APPD. |
|-------------|-------------|---------|-------|
| PRELIMINARY | | 7/16/99 | EJS |

| NO. | PART NUMBER | DESCRIPTION | QTY. |
|-----|----------------|-------------|------|
| 1 | MPM1423ATG7G3N | MOTOR | 1 |

| REV. | DESCRIPTION | DATE | APPD. |
|-------------|-------------|---------|-------|
| PRELIMINARY | | 7/16/99 | EJS |

| NO. | PART NUMBER | DESCRIPTION | QTY. |
|-----|----------------|-------------|------|
| 1 | MPM1423ATG7G3N | MOTOR | 1 |

| REV. | DESCRIPTION | DATE | APPD. |
|-------------|-------------|---------|-------|
| PRELIMINARY | | 7/16/99 | EJS |

| NO. | PART NUMBER | DESCRIPTION | QTY. |
|-----|----------------|-------------|------|
| 1 | MPM1423ATG7G3N | MOTOR | 1 |

| REV. | DESCRIPTION | DATE | APPD. |
|-------------|-------------|---------|-------|
| PRELIMINARY | | 7/16/99 | EJS |

| NO. | PART NUMBER | DESCRIPTION | QTY. |
|-----|----------------|-------------|------|
| 1 | MPM1423ATG7G3N | MOTOR | 1 |

| REV. | DESCRIPTION | DATE | APPD. |
|-------------|-------------|---------|-------|
| PRELIMINARY | | 7/16/99 | EJS |

| NO. | PART NUMBER | DESCRIPTION | QTY. |
|-----|----------------|-------------|------|
| 1 | MPM1423ATG7G3N | MOTOR | 1 |

| REV. | DESCRIPTION | DATE | APPD. |
|-------------|-------------|---------|-------|
| PRELIMINARY | | 7/16/99 | EJS |

| NO. | PART NUMBER | DESCRIPTION | QTY. |
|-----|----------------|-------------|------|
| 1 | MPM1423ATG7G3N | MOTOR | 1 |

| REV. | DESCRIPTION | DATE | APPD. |
|-------------|-------------|---------|-------|
| PRELIMINARY | | 7/16/99 | EJS |

| NO. | PART NUMBER | DESCRIPTION | QTY. |
|-----|----------------|-------------|------|
| 1 | MPM1423ATG7G3N | MOTOR | 1 |

| REV. | DESCRIPTION | DATE | APPD. |
|-------------|-------------|---------|-------|
| PRELIMINARY | | 7/16/99 | EJS |

| NO. | PART NUMBER | DESCRIPTION | QTY. |
|-----|----------------|-------------|------|
| 1 | MPM1423ATG7G3N | MOTOR | 1 |

| REV. | DESCRIPTION | DATE | APPD. |
|-------------|-------------|---------|-------|
| PRELIMINARY | | 7/16/99 | EJS |

| NO. | PART NUMBER | DESCRIPTION | QTY. |
|-----|----------------|-------------|------|
| 1 | MPM1423ATG7G3N | MOTOR | 1 |

| REV. | DESCRIPTION | DATE | APPD. |
|-------------|-------------|---------|-------|
| PRELIMINARY | | 7/16/99 | EJS |

| NO. | PART NUMBER | DESCRIPTION | QTY. |
|-----|----------------|-------------|------|
| 1 | MPM1423ATG7G3N | MOTOR | 1 |

| REV. | DESCRIPTION | DATE | APPD. |
|-------------|-------------|---------|-------|
| PRELIMINARY | | 7/16/99 | EJS |

| NO. | PART NUMBER | DESCRIPTION | QTY. |
|-----|----------------|-------------|------|
| 1 | MPM1423ATG7G3N | MOTOR | 1 |

| REV. | DESCRIPTION | DATE | APPD. |
|-------------|-------------|---------|-------|
| PRELIMINARY | | 7/16/99 | EJS |

| NO. | PART NUMBER | DESCRIPTION | QTY. |
|-----|----------------|-------------|------|
| 1 | MPM1423ATG7G3N | MOTOR | 1 |

| REV. | DESCRIPTION | DATE | APPD. |
|-------------|-------------|---------|-------|
| PRELIMINARY | | 7/16/99 | EJS |

| NO. | PART NUMBER | DESCRIPTION | QTY. |
|-----|----------------|-------------|------|
| 1 | MPM1423ATG7G3N | MOTOR | 1 |

| REV. | DESCRIPTION | DATE | APPD. |
|-------------|-------------|---------|-------|
| PRELIMINARY | | 7/16/99 | EJS |

| NO. | PART NUMBER | DESCRIPTION | QTY. |
|-----|----------------|-------------|------|
| 1 | MPM1423ATG7G3N | MOTOR | 1 |

| REV. | DESCRIPTION | DATE | APPD. |
|-------------|-------------|---------|-------|
| PRELIMINARY | | 7/16/99 | EJS |

| NO. | PART NUMBER | DESCRIPTION | QTY. |
|-----|----------------|-------------|------|
| 1 | MPM1423ATG7G3N | MOTOR | 1 |

| REV. | DESCRIPTION | DATE | APPD. |
|-------------|-------------|---------|-------|
| PRELIMINARY | | 7/16/99 | EJS |

| NO. | PART NUMBER | DESCRIPTION | QTY. |
|-----|----------------|-------------|------|
| 1 | MPM1423ATG7G3N | MOTOR | 1 |

| REV. | DESCRIPTION | DATE | APPD. |
|-------------|-------------|---------|-------|
| PRELIMINARY | | 7/16/99 | EJS |

| NO. | PART NUMBER | DESCRIPTION | QTY. |
|-----|----------------|-------------|------|
| 1 | MPM1423ATG7G3N | MOTOR | 1 |

| REV. | DESCRIPTION | DATE | APPD. |
|-------------|-------------|---------|-------|
| PRELIMINARY | | 7/16/99 | EJS |

| NO. | PART NUMBER | DESCRIPTION | QTY. |
|-----|----------------|-------------|------|
| 1 | MPM1423ATG7G3N | MOTOR | 1 |

| REV. | DESCRIPTION | DATE | APPD. |
|-------------|-------------|---------|-------|
| PRELIMINARY | | 7/16/99 | EJS |

| NO. | PART NUMBER | DESCRIPTION | QTY. |
|-----|----------------|-------------|------|
| 1 | MPM1423ATG7G3N | MOTOR | 1 |

| REV. | DESCRIPTION | DATE | APPD. |
|-------------|-------------|---------|-------|
| PRELIMINARY | | 7/16/99 | EJS |

| NO. | PART NUMBER | DESCRIPTION | QTY. |
|-----|----------------|-------------|------|
| 1 | MPM1423ATG7G3N | MOTOR | 1 |

| REV. | DESCRIPTION | DATE | APPD. |
|-------------|-------------|---------|-------|
| PRELIMINARY | | 7/16/99 | EJS |

| NO. | PART NUMBER | DESCRIPTION | QTY. |
|-----|----------------|-------------|------|
| 1 | MPM1423ATG7G3N | MOTOR | 1 |

| REV. | DESCRIPTION | DATE | APPD. |
|-------------|-------------|---------|-------|
| PRELIMINARY | | 7/16/99 | EJS |

| NO. | PART NUMBER | DESCRIPTION | QTY. |
|-----|----------------|-------------|------|
| 1 | MPM1423ATG7G3N | MOTOR | 1 |

| REV. | DESCRIPTION | DATE | APPD. |
|-------------|-------------|---------|-------|
| PRELIMINARY | | 7/16/99 | EJS |

| NO. | PART NUMBER | DESCRIPTION | QTY. |
|-----|----------------|-------------|------|
| 1 | MPM1423ATG7G3N | MOTOR | 1 |

| REV. | DESCRIPTION | DATE | APPD. |
|-------------|-------------|---------|-------|
| PRELIMINARY | | 7/16/99 | EJS |

| NO. | PART NUMBER | DESCRIPTION | QTY. |
|-----|----------------|-------------|------|
| 1 | MPM1423ATG7G3N | MOTOR | 1 |

| REV. | DESCRIPTION | DATE | APPD. |
|-------------|-------------|---------|-------|
| PRELIMINARY | | 7/16/99 | EJS |

| NO. | PART NUMBER | DESCRIPTION | QTY. |
|-----|----------------|-------------|------|
| 1 | MPM1423ATG7G3N | MOTOR | 1 |

| REV. | DESCRIPTION | DATE | APPD. |
|-------------|-------------|---------|-------|
| PRELIMINARY | | 7/16/99 | EJS |

| NO. | PART NUMBER | DESCRIPTION | QTY. |
|-----|----------------|-------------|------|
| 1 | MPM1423ATG7G3N | MOTOR | 1 |

| REV. | DESCRIPTION | DATE | APPD. |
|-------------|-------------|---------|-------|
| PRELIMINARY | | 7/16/99 | EJS |

| NO. | PART NUMBER | DESCRIPTION | QTY. |
|-----|----------------|-------------|------|
| 1 | MPM1423ATG7G3N | MOTOR | 1 |

| REV. | DESCRIPTION | DATE | APPD. |
|-------------|-------------|---------|-------|
| PRELIMINARY | | 7/16/99 | EJS |

| NO. | PART NUMBER | DESCRIPTION | QTY. |
|-----|----------------|-------------|------|
| 1 | MPM1423ATG7G3N | MOTOR | 1 |

| REV. | DESCRIPTION | DATE | APPD. |
|-------------|-------------|---------|-------|
| PRELIMINARY | | 7/16/99 | EJS |

| NO. | PART NUMBER | DESCRIPTION | QTY. |
|-----|----------------|-------------|------|
| 1 | MPM1423ATG7G3N | MOTOR | 1 |

| REV. | DESCRIPTION | DATE | APPD. |
|-------------|-------------|---------|-------|
| PRELIMINARY | | 7/16/99 | EJS |

| NO. | PART NUMBER | DESCRIPTION | QTY. |
|-----|----------------|-------------|------|
| 1 | MPM1423ATG7G3N | MOTOR | 1 |

| REV. | DESCRIPTION | DATE | APPD. |
|-------------|-------------|---------|-------|
| PRELIMINARY | | 7/16/99 | EJS |

| NO. | PART NUMBER | DESCRIPTION | QTY. |
|-----|----------------|-------------|------|
| 1 | MPM1423ATG7G3N | MOTOR | 1 |

| REV. | DESCRIPTION | DATE | APPD. |
|-------------|-------------|---------|-------|
| PRELIMINARY | | 7/16/99 | EJS |

| NO. | PART NUMBER | DESCRIPTION | QTY. |
|-----|----------------|-------------|------|
| 1 | MPM1423ATG7G3N | MOTOR | 1 |

| REV. | DESCRIPTION | DATE |
|------|-------------|------|
|------|-------------|------|