

MOTOR DATA @ 460 VAC (TRAP)

MOTOR PARAMETERS	UNITS	VALUE
HORSEPOWER	HP RATED	18.0
KILOWATTS	KW RATED	13.4
MAX. OPERATING SPEED	N. MAX RPM	1500
SPEED @ RATED TORQUE	N RATED RPM	1200
* CONTINUOUS RATED TORQUE @ 1200 RPM	IN-LBS[Nm]	939.0 [105.0]
* CONTINUOUS STALL TORQUE	IN-LBS[Nm]	1092.0 [123.0]
CONTINUOUS LINE CURRENT	AMPS	31.0
PEAK TORQUE	IN-LBS[Nm]	3276.0 [370.0]
PEAK CURRENT	AMPS	93.0
MAX. THEORETICAL ACCEL.	RAD/SEC ²	24.632
TORQUE SENSITIVITY	Kt [IN-LBS/AMP] [Nm/AMP]	35.0 [4.0]
BACK EMF (LINE TO LINE)	Vrms/Krpm	316.0
D.C. RESISTANCE (P-P)	OHMS	.72
INDUCTANCE (P-P)	MILLIHENRIES	13.4
ROTOR INERTIA	Jm [IN-LBS-SEC ²] [Kg-M ²]	.133 [0.150]
STATIC FRICTION	Tf [IN-LBS] [Nm]	13.0 [1.5]

*25°C AMBIENT WITH A MAXIMUM CASE TEMPERATURE OF 100°C ON MOTOR. MOTOR MOUNTED ON A 14" X 14" X 3/4" ALUMINUM HEATSINK. THERMOSTAT IN STATOR WINDINGS WILL OPEN IF WINDING TEMPERATURE EXCEEDS 155°C. THIS ALLOWS FOR AN APPROXIMATE +10% HEADROOM IN THE CONTINUOUS TORQUE RATING BEFORE THERMOSTAT OPENS.

- MECHANICAL NOTES:**
- AXIAL LOAD: 100 LBS MAX
 - RADIAL LOAD: 250 LBS MAX @ 1" FROM FACE
 - MOTOR SEALED TO IP65
 - MOTOR WEIGHT: 160 LBS [72.6 Kg]
 - MOTOR FINISH: BLACK EPOXY
 - MILLIMETERS (INCHES)

ENCODER: (290-00064)
OH48-1000P6-L6-5V

CONNECTION CHART

MOTOR CONNECTOR:
SG3102E-32-17P(027)
(270-00066)

MOTOR WIRE LEADS	WIRE FUNCTION	WIRE COLOR
A	ΦR	BLACK
B	ΦS	RED
C	ΦT	BLUE
D	PE GND	GRN/YEL

ENCODER/THERM CONNECTOR:

PT02E-14-18P(027)
(270-00024)

ENC/THERM WIRE LEADS	WIRE FUNCTION	WIRE COLOR
T	GROUND	BLACK
K	+5VDC	RED
B	CH A	BLUE
N	CH B	GREEN
P	CH B'	GRN/BLK
M	CH Z	YELLOW
U	CH Z'	YEL/BLK
E	CH U	BROWN
R	CH U'	BRN/BLK
F	CH V	GRAY
S	CH V'	GRAY/BLK
G	CH W	WHITE
H	CH W'	WHT/BLK
D	GND/CABLE	SHLD
A	THERM	BLACK
L	THERM	BLACK
J	GND	GRN/YEL

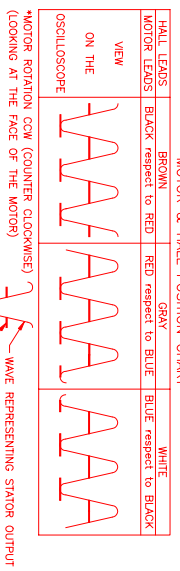
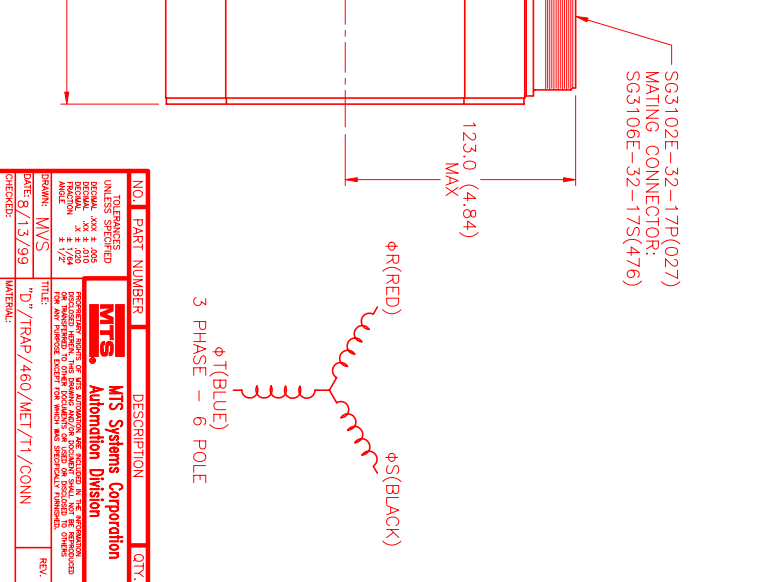
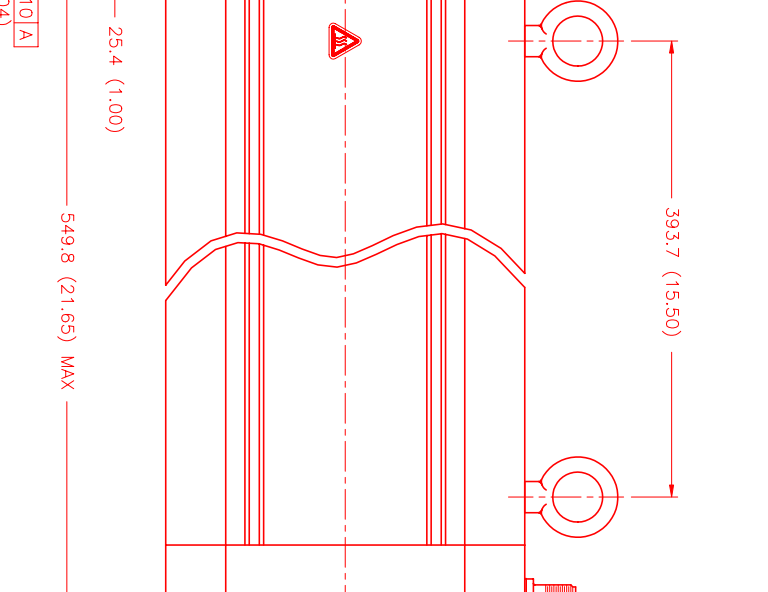
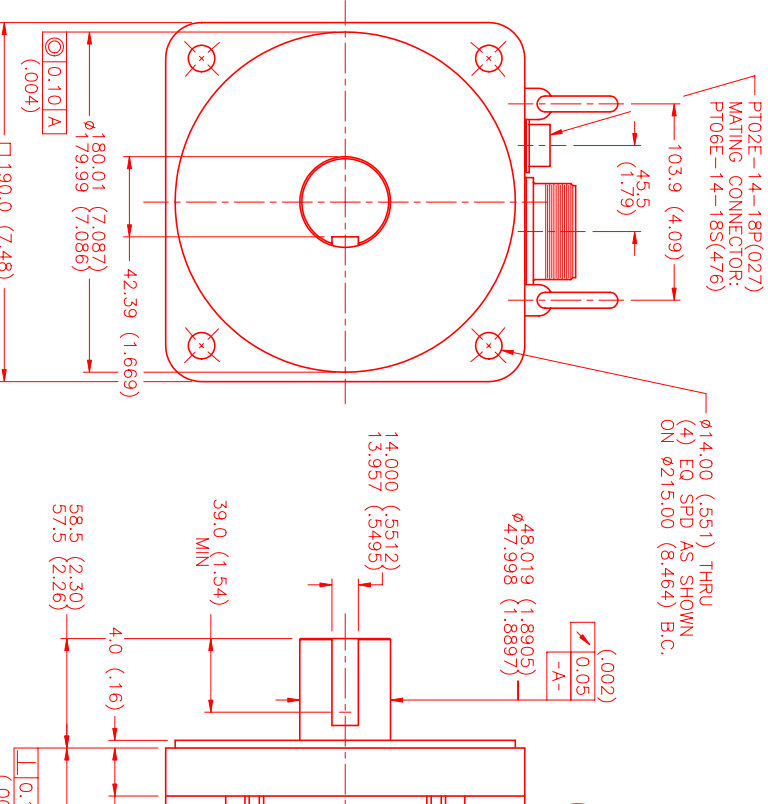

*MOTOR ROTATION CCW (COUNTER CLOCKWISE) (LOOKING AT THE FACE OF THE MOTOR)

REV.	DESCRIPTION	DATE	APPD.
PRELIMINARY		8/13/99	MVS

NO.	PART NUMBER	DESCRIPTION	QTY.
1	SG3102E-32-17P(027)	MOTOR	1
2	PT02E-14-18P(027)	ENCODER/THERM CONNECTOR	1
3	SG3106E-32-17S(476)	MATING CONNECTOR	1

MVS MVS Systems Corporation
Automation Division

DATE: 8/13/99
DRAWN: MVS
CHECKED: MVS
TITLE: "D"/TRAP/460/MET/T1/CONN
MATERIAL: ALUMINUM
SCALE: 1/2:1