

6K Controllers



Universal Motion Controller—The 6K

Compumotor's revolutionary 6K Controller is an embedded motion controller or stand-alone motion controller built into one convenient package. The 6K is a multi-axis motion controller capable of solving basic to complex motion control applications including: pick-and-place, packaging, following, cam profiling and hundreds of others. The 6K utilizes Ethernet communications to allow high speed connections to many different products such as PLCs, HMIs, I/O modules and vision systems.

The 6K comes with Compumotor's latest software interface, Motion Planner™, to allow for seamless integration and quick setup of the 6K. Motion Planner™ utilizes programming wizards, which eliminate the need to learn a proprietary language and take the chore out of repetitive programming tasks, and a SmartEditor™ to virtually eliminate debug time. ServoTuner™, a graphical tuning tool, and PanelMaker™, a VB Script interface, are also included with Motion Planner™.

Universal Connectivity

The 6K is truly universal, providing industry standard +/- 10V or step-and-direction output. It is capable of controlling any combination of steppers and servos from 1 to 8 axes.

With its Ethernet capability, the 6K offers a flexible communication scheme compatible with hundreds of Ethernet devices on the market. From HMIs and PLCs to industrial I/O and vision systems, the 6K can connect to them all. Ethernet is a vendor-neutral, industry-accepted communication protocol, and it is very inexpensive to implement. The addition of fieldbus options (6K Profibus-DP and 6K DeviceNet) offer connectivity to PLCs and PCs using industry-standard protocols and hardware.

Networking

Every 6K Controller has a programmable IP address so single or multiple 6Ks can be easily networked in an Ethernet LAN. Ethernet devices such as hubs or switches allow multiple controllers to be linked onto a single LAN.

With the addition of more sophisticated equipment, complex factory networks incorporating motion control are possible, allowing easier troubleshooting and wider access to the controller.

Flexibility and Expandability

Expansion I/O allows the 6K to expand with your application.

The EVM32 expansion I/O module allows easy configuration of digital I/O, analog I/O, and relay points in addition to the already extensive amount of standard 6K I/O.

Programmability

The 6K is built on the solid platform of Compumotor's 6000 Programming Language. With powerful features such as cam following, multitasking, PLC Scan Mode, PLS (Programmable Limit Switch) functionality, contouring, and teach mode, the 6K can handle the most demanding of applications. Yet program development time is greatly reduced with wizards, which uses a simple graphical environment to build the program structure, making the 6K easier than ever.

*Motion Architect, Servo Tuner and CompuCAM are registered trademarks of Parker Hannifin Corporation, Compumotor Division
Microsoft Windows is a registered trademark of Microsoft Corporation*

*Motion Toolbox is a registered trademark of Snider Integration Group
LabVIEW is a registered trademark of National Instruments Corporation
All others are trademarks of their respective companies*

Discover How The 6K Motion Controller Can Solve Your Next Application. Call 1-800-358-9070 Today.

Fieldbus and the 6K

The 6K controller offers fieldbus options! For applications requiring a dedicated network to carry I/O and controller status information to and from PLCs or PCs, Compumotor has developed Profibus-DP and DeviceNet options for the 6K.

6K Fieldbus Specifications

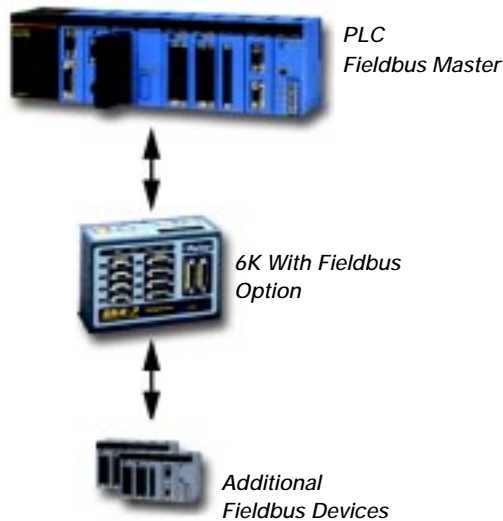

- Profibus-DP or DeviceNet implementation
- Passive station (Slave device)
- Parity and cable disconnect error checking
- Cyclical Data Transfer
 - * Profibus-DP
 - Dual port transfer of first 16 binary variables
 - * DeviceNet
 - Dual port transfer of first 16 binary variables
- Network Addressing
 - * Profibus-DP
 - Manual addressing up to 127 nodes
 - * DeviceNet
 - Manual addressing up to 63 nodes

NOTE: Fieldbus options are not field installable. Call your local Automation Technology Center or Compumotor to order a fieldbus version of the 6K.

Expandable I/O

The ability to add digital and analog I/O to the 6K makes it a very flexible and attractive controller choice for both OEMs and end-users alike. You are free to choose exactly how much I/O your system requires. The expansion I/O of the 6K ensures that you pay only for the I/O that you need. Contrast this to other controller manufacturers that make you pay for a fixed amount of I/O regardless of whether you utilize all of it or not.

EVM32

The EVM32 is a compact and rugged DIN Rail-mountable module that houses up to 32 channels of I/O. Up to eight EVM32 modules may be used with each 6K. SIM (Single In-Line Module) cards are added to the EVM32 to expand the I/O.



SIM cards are available with:

- 8 analog inputs
 - 12-bit (+/- 10 V)
- 8 analog outputs
 - 10-bit (+/- 10 V)
- 8 digital inputs
 - 24 VDC, sourcing or sinking is jumper selectable
 - LEDs for visual reference
- 8 digital outputs
 - 24 VDC, sourcing or sinking, 300 mA current sink, short circuit protected
 - LEDs for visual reference
- 8 reed relay outputs
 - 10 Watt max power*
 - 0.5 A max current, 75 V max voltage*
 - 400 μ s activation time typical
 - 100 μ s release time typical

* **Note:** On the reed relay SIM, neither power, current nor voltage should ever exceed the maximum rated values listed. Exceeding the rated values will damage the reed relay SIM. Example: 10 Watts = 0.416 Amps @ 24 Volts.

Configuration

SIM cards may be added to the EVM32 to achieve a maximum of 256 bits (32 bits per EVM32 times eight EVM32 modules per 6K):

- 256 additional bits
 - 256 digital inputs
 - 256 digital outputs
 - 64 analog inputs (4 bits per input)
 - 64 analog outputs (4 bits per output)
 - 256 reed relay outputs

Note: The actual number of digital outputs is dependent on heat. Please consult the product documentation to determine duty cycle and load considerations.

Features

Motion

- 1-8 axes of stepper/servo control (any combination)
- Outputs standard +/- 10V or step & direction
- Servo update rates of 62.5 μ s/axis

Interface Capability

- 10 Mbps twisted pair Ethernet
- Multiple protocols
- 1 RS232 port (3 wire) - 9600 or 19200 baud
- 1 RS232/485 port (2 or 4 wire) - 9600 or 19200 baud
- Profibus-DP option
- DeviceNet option
- Parker CTC Motion Panel™, PowerStation™ and other CTC touchpanels via Ethernet or RS232/485

Language and Software

- Wizards-based Motion Planner™ Software provided
- Compumotor 6000 programming language
- Multi-tasking (Up to 10 separate tasks)
- Position based following
- Contouring (2-axes circular, tangent & proportional third axis)
- Compiled moves
- PLC Scan Mode
- PLS (Programmable Limit Switch) capability
- Scaling
- Cam profiling
- Variables and high level math functions
- 300K non-volatile memory for program storage

Physical

- Standalone operation
- PC-based control via Ethernet
- Fieldbus via Profibus -DP or DeviceNet
- 24VDC user supplied
- DIN Rail mountable

Onboard I/O

- 5-24 VDC
- Home, Positive and Negative Limits per axis
- 9-17 fast trigger inputs for high-speed position capture
- 4-8 digital outputs
- Drive Fault output per axis
- Shutdown and Enable inputs per axis
- 12 MHz encoder input for each axis
- Auxiliary encoder input for following

Expansion I/O

- 12-24 VDC, 32 channel expansion modules
- Up to 256 digital I/O points
- Up to 64 analog I/O points
- All digital I/O is updated every 2ms
- Digital I/O have LEDs for visual reference
- Compatible with Ethernet I/O



Discover How The 6K Motion Controller Can Solve Your Next Application. Call 1-800-358-9070 Today.

Ethernet

What is Ethernet?

Ethernet Today

Ethernet is a well-known and widely used communication protocol that has been in existence since the 1970s when it was developed by Xerox. Since that time it has expanded rapidly and today it is the most commonly used LAN in existence. We know Ethernet best for its everyday uses such as email, Internet and Intranet.

Availability of Ethernet

Ethernet is an open platform serial communication that is vendor neutral. It is governed by the IEEE 802.3 standard adopted in 1985. Due to the large market and availability, Ethernet component choices are numerous and inexpensive. Since Ethernet is a standard, connectivity between a wide range of Ethernet capable products is fast and easy.

Ethernet Mediums

The medium over which Ethernet communication is transmitted is varied. The most common medium to date is 10Base-T. 10Base-T means a 10-Mbps (10 million bits per second) baseband signal carried over twisted pair cable. Most facilities using Ethernet are using 10Base-T as their medium. Other mediums used are 10Base5 and 10Base2, thick coaxial and thin coaxial cable respectively. 10Base-F is a fiber optic medium. 100 Base-T is becoming more common today. . . .

Communication Protocol

Ethernet is a standard of communication between hardware devices. Several protocols, or languages, are spoken over the Ethernet network and provide a common interface between devices. TCP/IP (Transfer Control Protocol/Internet Protocol) is by far the most prevalent protocol due to its common usage in office environments. Protocols such as Modbus/TCP and AB Ethernet have become more popular in industrial environments over Ethernet networks because they support industrial device communication better than typical PC protocols such as TCP/IP.

Summary

The availability of Ethernet, a wide range of Ethernet products, extremely fast communications, and proven communication protocols make Ethernet a perfect choice for networking and communication between industrial devices.

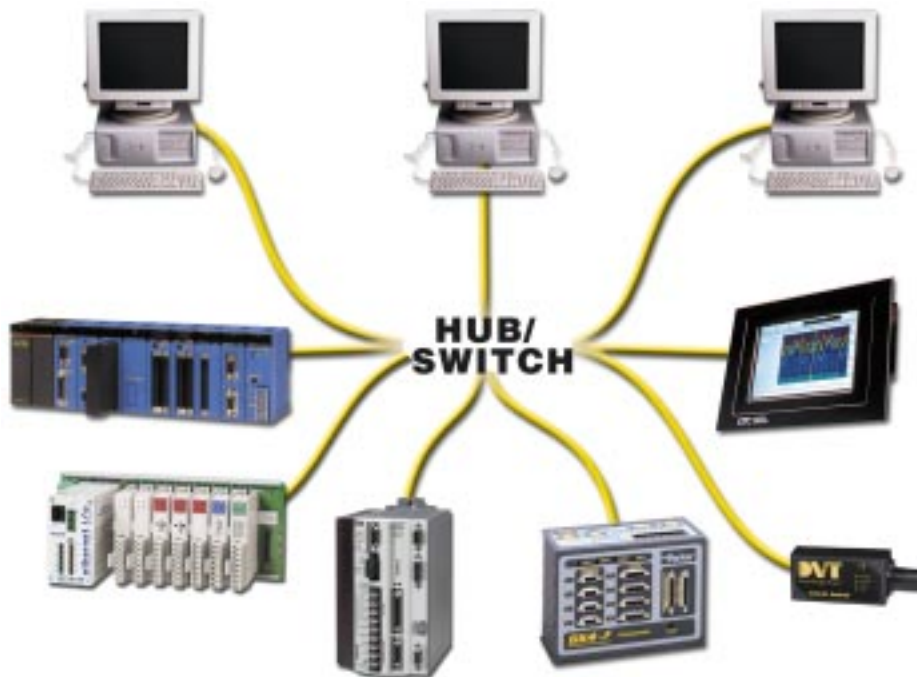

Visit DVT on the web at
www.dvtsensors.com

Ethernet and Motion Control

Motion Control Via Ethernet

Ethernet was developed as a high-speed method of communication between two computers. When looking at a motion controller it is obvious that it is nothing more than a highly specialized computer; therefore, it makes sense to use Ethernet for high-speed communication between an industrial computer and a motion controller.

Ethernet Flexibility

On the market today are thousands of products with Ethernet communication capability. A motion controller using Ethernet can join these products on a LAN and share information with I/O modules, sensors, PLCs, HMIs and vision systems, to name a few. Additionally, Ethernet controllers allow connectivity to not just one PC but literally thousands and can have several host computers located throughout an entire factory.

Incorporating TCP/IP protocols in an Ethernet controller also allows for access to the Internet and other software and devices utilizing TCP/IP. Now you can sit at your desk and upload or download information to a motion controller on the factory floor. The factory floor might be in another building, another state or another country.

Ethernet Networking

With the popularity of Ethernet growing on the plant floor, the ability to network industrial devices over ethernet has become a viable alternative to traditional fieldbus. This type of communication is typically handled via a client/server relationship over the ethernet network.

The client is the device that opens a connection to a server and queries for information or commands some action. The client on an Ethernet network is synonymous with a "master" on a traditional fieldbus network. The server is the device that, once queried by a client, serves the information back to or carries out the actions commanded by the client and is synonymous with a "slave" on a traditional fieldbus network. As an example, in a system with a 6K and a PC running Motion Planner, the PC is the client and the 6K is the server. The following explains two ways to use networking capability of the 6K or Gem6K.

6K or Gem6K as a Client

You can connect the 6K via Ethernet to multiple devices, creating a client/server network. The 6K is the *client*, and has the ability to open or close a connection with another device (*server*) and request information from that device. The 6K supports up to 6 simultaneous server connections. Devices (servers) that may be connected to the 6K include:

- Allen Bradley SLC5-05 PLC, using AB Ethernet protocol
- OPTO22 SNAP I/O, using Modbus/TCP protocol
- DVT vision system cameras

Peer-to-Peer Network with other 6K or Gem6K units

The 6K may be connected to other 6K devices (6K Controllers or Gem6K drive/controllers) via Ethernet. This type of connection uses *UDP broadcasting* and is *not* a client/server relationship.

Data Chain is a peer-to-peer network created by Compumotor to share data between multiple 6K/Gem6K units. Up to eight units may broadcast on the Ethernet network simultaneously with an unlimited number of units subscribing to these broadcasts. Each broadcast unit may send up to eight 32-bit values. Each subscribing unit may receive all eight values from each broadcast unit, adding up to a possible 64 values in each subscribing units. The update rate in each unit is user definable for maximum system performance.

Determinism

Ethernet is a flexible alternative to traditional bus-based control. It also offers an attractive networking solution on a widely accepted platform. It is important however to understand how the 6K integrates on an open network. For applications requiring minimal data transfer such as periodic scanning of product status or program downloads, this can be accomplished on an open network. For highly data intensive applications such as continuously updating visual interfaces, Compumotor recommends a direct PC to 6K Ethernet connection via a crossover cable. For applications requiring intensive data transfer network access, isolate the 6K from the open network using an Ethernet switch.

Utilizing Ethernet as a motion control communication scheme makes sense from an economic, technological and adaptability standpoint. The sheer number of Ethernet compatible products and the low cost of obtaining Ethernet technology make it an attractive solution for many years to come.



Discover How The 6K Motion Controller Can Solve Your Next Application. Call 1-800-358-9070 Today.

The 6K Software

The Right Idea and the Right Tools

Motion Planner™

Motion Planner is a code development package like no other. Several features are incorporated to assist novice and expert users alike in developing code. Develop your code correctly the first time with powerful wizards and debugging tools. Tune servos quickly and easily with built in servo tuning software. Create visually appealing user interfaces with our PanelMaker Visual Basic scripting tool. Motion Planner is an essential part of any 6K project.

Wizards

Working with Compumotor's 6K multi-axis motion controllers just got even easier. Now the 6K's Motion Planner™ application software comes with wizards, eliminating any need to learn a proprietary language. Let our wizards do the programming for you!

- Develop your application code in one-third the time
- Multiple, modular wizards for set up, error handling, networking and all motion commands
- Generate error-free application code with full comments
- Eliminate the need to learn specific command syntax.

It's Free

Motion Planner is shipped free with every 6K and together they present hardware and software designers with a faster and better motion control solution than ever before. We have spent time perfecting our software so you don't have to spend your time putting it to work. Motion Planner software is also available for free at our website: (www.compumotor.com).



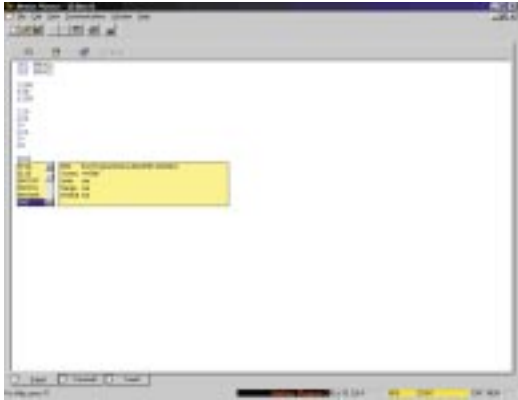

SmartEditor™

Creating code is one of the most time consuming aspects of system development. The software designers at Compumotor understand this, so Motion Planner's editor was designed with efficiency in mind. The SmartEditor™ incorporates these functions:

- Automatic syntax checking as you type
- Color coded syntax highlighting
- Ever present help screen to access command descriptions

Motion Planner's SmartEditor™ will virtually eliminate syntax debugging and will help you generate efficient error free code the first time.



PanelMaker

You spend a lot of time developing your application potential. You need a way to relay that potential to users and operators. Motion Planner's PanelMaker features allows you to create informative and aesthetically pleasing interface screens without purchasing expensive software. PanelMaker utilizes powerful Microsoft® Visual Basic™ scripting to assist in panel creation. If you are already familiar with Visual Basic™ you will find the programming very similar and if not, we have created several pre-defined interfaces for you in our interface gallery. An ActiveX control is also provided for fast checking of controller parameters.

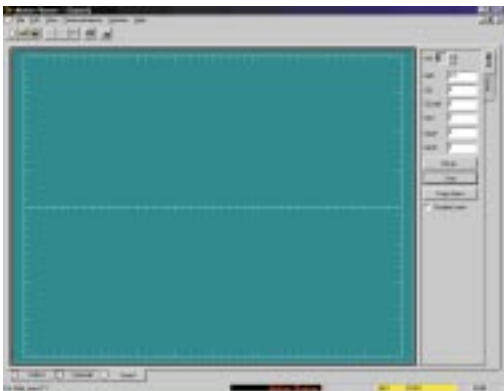

ServoTuner™

To help you optimize your servo axes and speed you on your way towards creating motion, Motion Planner™ includes a servo tuning utility. Using ServoTuner™ you can change all tuning gains and see the motor response on the graphical tuning interface. Motion Planner™ will seamlessly integrate your programming, setup and tuning so you spend more time developing your application's full potential.

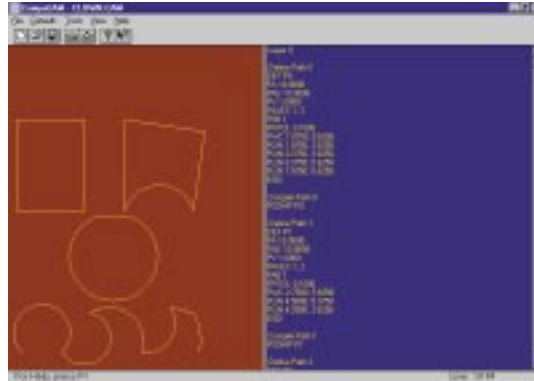

CompuCAM

Now you can convert your .DXF, HPGL or G-Code files directly into language that the 6K understands with CompuCAM. Built-in filters, available for this add-on utility to Motion Planner™, allow quick creation of complex contouring code. All scaling and tolerances are handled within CompuCAM, just set your default parameters, import your file to create the 6K code. It's that easy!

Discover How The 6K Motion Controller Can Solve Your Next Application. Call 1-800-358-9070 Today.



6K Language

Now More Powerful than Ever!

The 6000 Motion Control Language is the cornerstone of Compumotor's control products. Users of 6000 products value the simple yet powerful nature of the 6000 Language. Several major software features have been added to the 6K to make it even more powerful:

- Multitasking
- PLC Scan Mode
- PLS (Programmable Limit Switch)
- Virtual Master
- Web Registration
- Repetitive Cycle

These features add to the already impressive list of 6000 Language features such as:

- Contouring
- Cam Profiling
- Teach Mode
- Data Arrays
- Position Following
- Registration

Multi Tasking

The 6K offers pre-emptive multitasking which allows the user to simultaneously run up to 10 tasks from one controller. Separate logic and motion programs can now be created and executed at the same time allowing more flexible error handling and I/O monitoring than ever before.

PLC Scan Mode

PLC Scan Mode allows you to mimic the functions of a PLC. A high speed compiled program is dedicated to scan as fast as 2 ms and handles only logic functions such as error bits, I/O bits, variables and timing to ensure high-speed scanning. PLC Scan Mode also allows powerful features to be programmed including PLS functionality (Programmable Limit Switches).

Following

The 6K introduces three new following features to its repertoire:

- Virtual Master allows you to follow an internal count source to solve multi-axis electronic cams and sinusoidal move profile applications.
- Web Registration allows you to easily handle web processing applications with dedicated registration handling subroutines.
- Following Repetitive Cycle defines a motion synchronized to a repetitive external event such as high speed cut-on-the-fly.

MotionPanel for the 6K Controller and Gem6K Drive/Controller

Cut your motion/HMI setup time from hours to minutes! With MotionPanel's menu-driven interface, you can manage multiple 6K motion programs without having to write and debug additional code. Unlike two- and four-line alphanumeric displays, MotionPanel provides easy-to-read touchscreens (optional color displays are available) with more understandable menus for the user. With the Windows-based Interact development software, you can even customize panels to simplify and enhance screens for the operator. Try doing that with a proprietary alphanumeric display device!

This PC-based flexibility, combined with high-speed Ethernet communications, provides the most advanced, easy-to-use motion/HMI package available for machine control today!

- Automatically detects up to 8 axes of 6K motion
- Automatically detects digital and analog expansion I/O
- Instantly uploads motion programs from solid-state Compact FLASH disk - including scaling
- PC-based hardware/software with an upgrade path to advanced HMI functionality

Plug and Play Setup

1. Connect Ethernet cable.
2. Power up MotionPanel.
3. Enable Compumotor 6K Ethernet connection.
4. Touch the pre-configured panels and go!



Four Machine Control Architecture Types

Machine control is the control of all elements of a machine or stand alone system. The elements can include motion control, control of the inputs and outputs, control of analog inputs and outputs from more advanced sensors, interface to the human machine interface (HMI), and communication with the enterprise level of the factory or other equipment.

As a motion control company, Compumotor engineers our products to tightly couple with machine control products. The following presentation over the next three pages highlight four common approaches for a machine control solution. Displayed with each machine control architecture is the 6K solution and the options for connection between the devices.

Motion Controller Based Machine Control

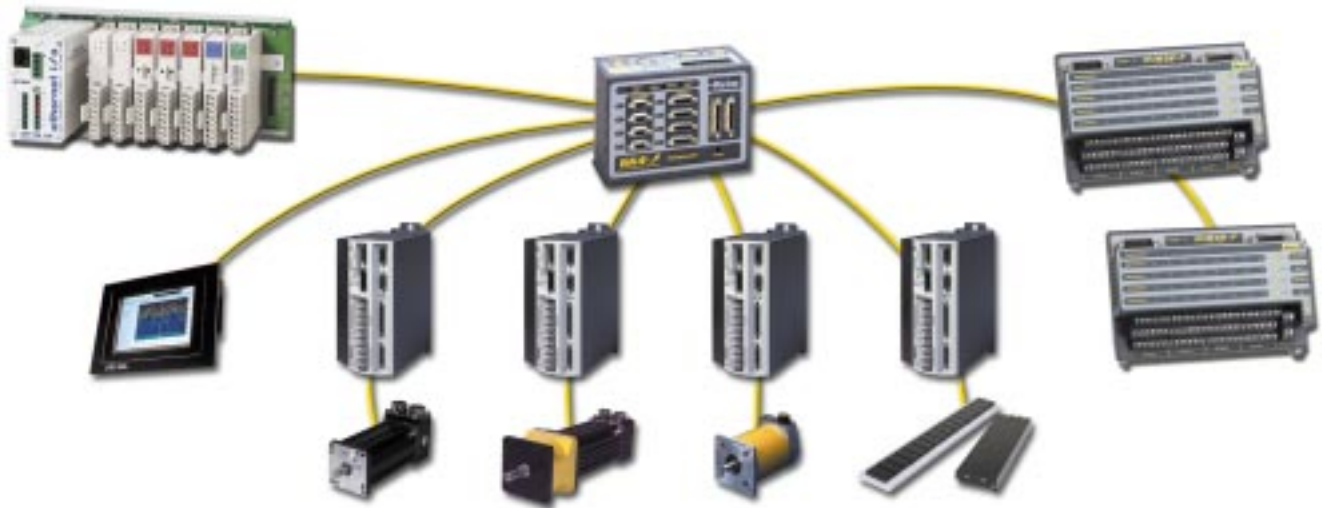

System Description

Many applications from low to moderate complexity can eliminate a separate machine control component and use the motion controller as the sole machine control. Motion controller capabilities have been expanding rapidly and are capable of controlling inputs and outputs as well as motion parameters. For many applications, this can provide the tightest coupling between a motion function and a machine control function.

For this type of control scheme the motion controller must be a stand-alone controller. A stand-alone controller has its own operating system and must be able to be installed as an individual component. In addition, the controller must be able to interface to human machine interface for data entry and be capable of efficiently controlling inputs and outputs.

This control scheme can also be used to break apart a complex machine into several simpler machine control components. In this case, communication between the sub-components must be fast and efficient.

Key Advantages with this Control Scheme:

- Best value for low to moderate complexity applications
- One programming platform for all machine control functions
- Tight coupling between motion control and machine control

Typical Applications:

- Less than 256 I/O points
- Tight coupling of machine control and motion control like electronic cam control

How the 6K Fits:

The 6K has several unique features to help integrate it easily as a machine control solution:

- PLC scan mode allows high scan rates on specified I/O points or registers
- Expandable I/O of the 6K with the EVM modules allows customization and expandability up to 256 I/O points
- Drivers to CTC's full family of human machine interfaces



Discover How The 6K Motion Controller Can Solve Your Next Application. Call 1-800-358-9070 Today.

Four Machine Control Architecture Types

PC-Logic Control (PCLC) Based Machine Control

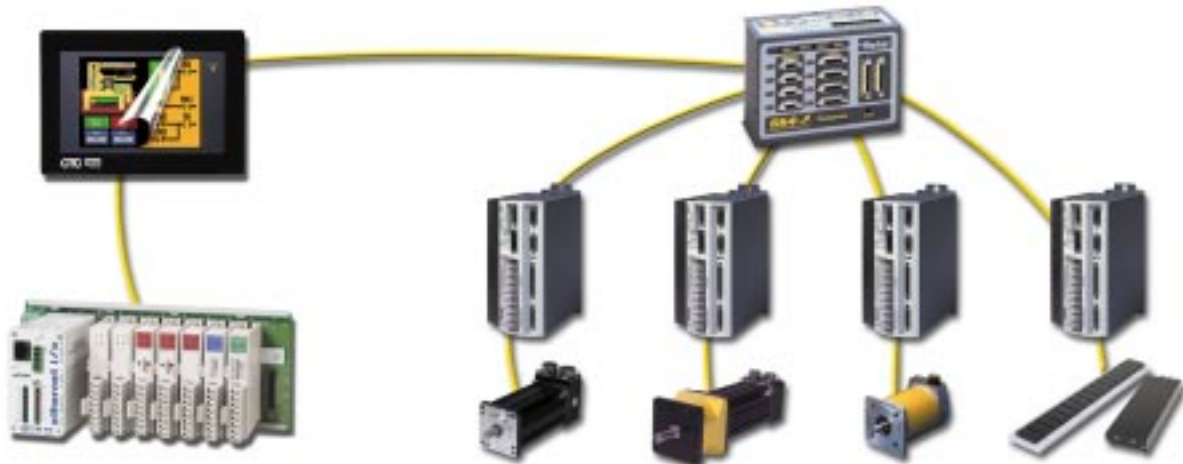

System Description

Traditional industrial control methodologies meet with PC industry driven performance and price with the PCLC control type. By using a software-based PLC, or "soft control", cost effective PLC replacement is a reality.

MachineLogic™ is a DOS-based real time operating system control program that was developed by CTC, a division of Parker Hannifin. The program provides deterministic control that runs on any PC or any CTC PowerStation human-machine interface (HMI). As a real-time system, a hard disk is not required for operation removing a potential source of failure. Because soft control is provided with all the popular PLC programming languages, there is no need for incremental learning.

This solution provides the open environment inherent with PCs without having to reeducate the whole factory. This approach enhances supportability and minimizes the learning curve for programming and developmental tools.

This solution fully integrates HMI with the machine control in a tightly coupled and rugged package.

This machine control method is especially cost effective when used with a PowerStation HMI. For the same price of a HMI comes all the processing power of a machine controller.

Key Advantages With This Control Scheme:

- CTC PowerStation flash memory is more rugged than a PC hard disk
- Real time and deterministic behavior (Windows™ NT cannot guarantee this)
- Maintainable just like a PLC (programming language already known to maintenance and programmers)
- Reliable HW and SW integration when using PowerStation
- Standard network support for ease of information flow
- Common development environments save time and money
- New engineers are more familiar with PCs than PLCs
- System solution available through one vendor (motion, HMI, PLC), all fully integrated

Typical Applications

- Less than <500 I/O points
- Needed combination of HMI with the control engine or needed higher speed graphics

How the 6K Fits

- The 6K connects directly to the CTC PowerStation family with either an Ethernet or RS232/485 connection. Drivers are available with each PowerStation to make integration a snap.

Four Machine Control Architecture Types

PC-Based Machine Control



System Description

As a machine controller, no other device can compete with a common PC or Industrial PC in the areas of flexibility and the sheer versatility it can offer. Since the early 1980's, when the PC was first used to control industrial automation systems, industry has witnessed a technology explosion from extremely slow and limited memory machines into the very powerful and productive machines available today. A direct result of this increased power is that many industrial automation manufacturers have turned to the PC as a machine controller.

The PC is the natural choice for data intensive applications and also applications that benefit from front-end Windows-based software and operator interfaces. Many applications have specific data handling and visual display requirements that cannot be handled by other types of machine control.

Additionally, industrial automation users have found that there is a multitude of communication protocols for the PC providing several connectivity options. Bus-based cards, which fit into an empty computer expansion slot, RS-232, RS-485 serial communications, and most recently high-speed Ethernet communication are all used to communicate between the PC and control hardware.

Compumotor offers a line of motion control for any connectivity need. RS-232 and Ethernet interfaces are available in single- or multi-axis controllers. Ethernet is the latest platform gaining popularity in industrial environments and offers a simple, inexpensive yet very high-speed connection to the PC and other industrial devices.

Key Advantages With This Control Scheme

- Handles data intensive applications
- Variety of connectivity options
- Front end software can be customized
- New engineers are more familiar with PCs than PLCs

Typical Applications

- Data acquisition/processing in addition to machine control—handling large amounts of data
- Networking of many machines or to other factory activities—connectivity to plant information technology system
- Need for central control of I/O devices distributed over a large area

How the 6K Fits

- The 6K communicates with any PC system via a 10Base-T Ethernet port making it a solution for bus-based machine control schemes. Connections are established by using the 6K Communications Server which is included on the Motion Planner™ CD ROM. The 6K Communications Server is a 32-bit OLE automation (COM) server which facilitates communications between 6K controllers and PC software applications. It is compatible with any 32-bit software application or programming environment which can utilize an OLE automation component, including Visual Basic, Visual C++, and JAVA. Individual commands or entire motion programs can be sent from the computer program to the 6K Controller. Likewise, alarm information and fast status updates are sent from the 6K back to the computer.



Discover How The 6K Motion Controller Can Solve Your Next Application. Call 1-800-358-9070 Today.

Four Machine Control Architecture Types

PLC-Based Machine Control

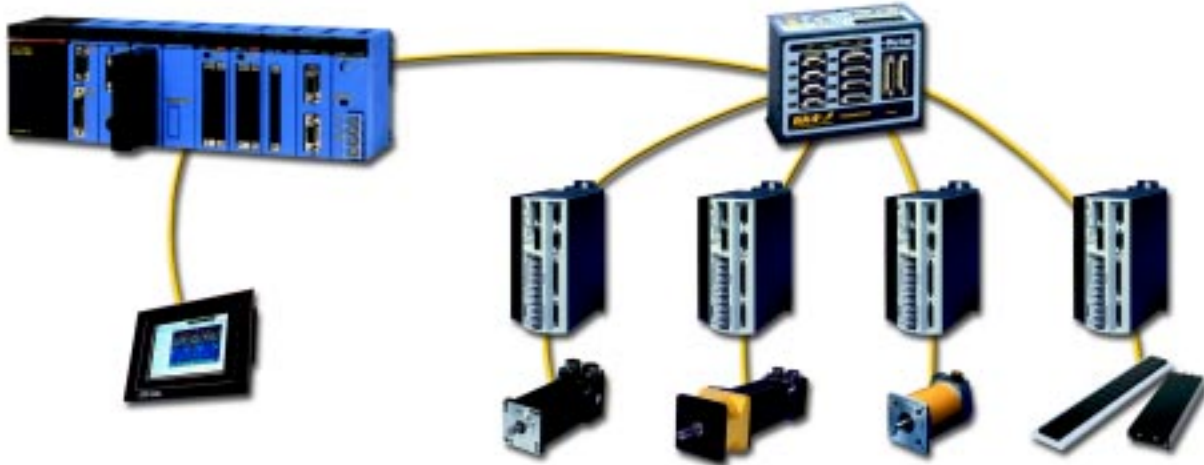

System Description

The programmable logic controller or PLC is the most common type of machine control and by far the most prevalent. PLCs were first developed in the late 1960s as an alternative to the relay cabinets that were the most common solution for machine control. Thirty years later, PLCs have had continual iterative developments and are now extremely reliable and flexible devices for machine control.

PLCs are perfect for applications requiring hundreds or thousands of I/O points and can control complex processes. Their weakness however has been in interfacing with complex equipment outside of the PLC rack such as vision systems and motion control equipment. Traditionally, the PLC used discrete outputs to communicate to the peripheral devices. This placed a great limitation on the type of communication that was possible and made the transmission of numerical values very inconvenient. Often an ASCII module was added to the PLC solely to communicate to the device.

The recent advent of the fieldbus promises to greatly increase the flexibility of communication by developing standards for communication that could bring many elements together.

Key Advantages with this Control Scheme:

- High reliability
- Proven technology
- On line editing

Typical Applications

- I/O centric applications (I/O control is the most critical criteria)
- Process control
- Greater than 500+ I/O points

How the 6K Fits

The 6K has several unique features to help integrate it easily with a PLC based system:

- Fieldbus interface cards for Profibus-DP and DeviceNet allow new levels of compatibility
- Ethernet interface using AB Ethernet protocol
- RS232/485 communication
- Functions controllable via discrete inputs and outputs

Specifications

Parameter	Parameter Type	Value
Power	Input	24 VDC, 2 Amp, User Supplied Additional power may be required for I/O use See Installation Guide for Details
Environmental	Operating Temperature	32° to 122°F (0° to 50°C)
	Storage Temperature	-22° to 185°F (-30° to 85°C)
	Humidity	0% to 95% non-condensing
Performance	Command	+/- 10V or Step & Direction Configurable per axis
	Servo Update	As fast as 62.5 μs/axis
	Encoder	Two phase quadrature detect incremental encoders with differential (recommended) or single ended outputs (+5 VDC TTL compatible) Max Frequency = 12 MHz post quadrature
	Stepping Accuracy	+/-0 steps from preset total
	Position Range	+/-2,147,483,648 counts
	Velocity Range	1 to 2,048,000 counts/sec (step & direction output) 1 to 12,000,000 counts/sec (+/- 10V output)
	Inputs	End-of-Travel & Home Limits per axis
Inputs	Onboard	Fast trigger inputs 9 on 6K2 & 6K4, 17 on 6K6 & 6K8 Factory default is 24 VDC sourcing Jumper TRIG-P to GND for sinking 0-24 VDC range through VIN _{ref} 1/3 1/3 1/3 voltage switching threshold
	EVM32 Expansion (optional)	Up to 256 digital inputs (2 ms update rate) Up to 64 12-bit analog inputs (+/- 10 VDC) 12-24 VDC user supplied through EVM32 module 1/3 1/3 1/3 voltage switching threshold on digital inputs LEDs provided on digital inputs for visual reference
	Outputs	Onboard
Outputs	EVM32 Expansion (optional)	Up to 256 digital outputs (300 mA maximum current sink)* Up to 64 10-bit analog outputs (+/- 10VDC) 12-24 VDC user supplied through EVM32 module Up to 256 relay outputs (0.5 A) LEDs provided on digital and relay outputs for visual reference
	Communications	Ethernet
Communications	Serial	RS-232, RS-485 2-wire or 4-wire Up to 115,200 baud, Up to 99 units in daisy-chain or multi-drop
	* Maximum number of outputs and maximum current sink are heat dependent. See product documentation for duty cycle considerations.	



Discover How The 6K Motion Controller Can Solve Your Next Application. Call 1-800-358-9070 Today.

Front Surface Connectors

Encoder • 9-pin D connector, female

Pin No.	Signal
1	+5VDC
2	A+
3	A-
4	B+
5	B-
6	Z+
7	Z-
8	Single Ended
9	ISO GND

Drive • 15-pin D connector, female

Pin No.	Signal
1	Step+ (stepper)
2	Direction+ (stepper)
3	Command+ (servo)
4	Stall (stepper)
5	Drive Fault (both)
6	Command- (servo)
7	Shutdown (NO) (servo)
8	Shutdown (NC) (servo)
9	Step- (stepper)
10	Direction- (stepper)
11	Shutdown+ (stepper)
12	Shutdown- (stepper)
13	ISO GND (both)
14	Shtdn Common (servo)
15	Analog Ground (servo)

Limits/Home • 25-pin D connector, female

Pin No.	Signal
1	Home4
3	Neg4
5	Pos4
7	Home3
9	Neg3
11	Pos3
13	Home2
15	Neg2
17	Pos2
19	Home1
21	Neg1
23	Pos1
25	Reserved
Even	ISO GND

Triggers/Outputs • 25-pin D connector, female

Pin No.	Signal
1	Output4
3	Output3
5	Output2
7	Output1
9	Trigger8
11	Trigger7
13	Trigger6
15	Trigger5
17	Trigger4
19	Trigger3
21	Trigger2
23	Trigger1
25	Reserved
Even	ISO GND

Top Surface Connectors

Power Input • 12-pin Screw Terminal

Pin No.	Signal
1	SHIELD
2	ISO GND
3	ENABLE
4	OUT DIODE
5	MASTER TRIG
6	ISO GND
7	CNTRL-P
8	LIM-P
9	TRIG-P
10	VINref
11	24 VDC RTN
12	+ 24 VDC PWR

Master Encoder Input • 9-pin D connector, female

Pin No.	Signal
1	+5VDC
2	A+
3	A-
4	B+
5	B-
6	Z+
7	Z-
8	ISO GND
9	ISO GND

I/O Expansion (15-pin D connector, male)

Connection to the expansion I/O modules. I/O modules sold separately. Up to 256 digital inputs, 256 digital outputs, 64 analog inputs, 64 analog outputs, and 256 relay outputs.

RS-232/485 (9-pin connector, male)

Configurable for RS-232 or RS-485 at 9600 to 115,200 baud

RS-232/Fieldbus In (9-pin D connector male)

RS-232 port at 9600 to 115,200 baud
 Data in port on fieldbus options

Ethernet (RJ45 Connector)

10Base-T Ethernet connection with TCP/IP and UDP protocol



Ordering Information and Part Numbers



Controller

I/O Screw Terminal Breakout



Expansion I/O*



Power Supply

PS-60W
 60 Watt 24 volt DC power supply

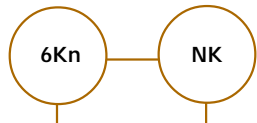

n= 2 – 2 axes
 n= 4 – 4 axes
 n= 6 – 6 axes
 n= 8 – 8 axes

No ship kit (omit to include ship kits)

VM25 25 pin-D to screw terminal breakout board w/ 2' cable (for use with onboard I/O)

MotionPanel™



See HMI section for product details

- EVM32-BASE Expansion I/O module w/ 2' cable and cover
- SIM8-IN-EVM32 8 digital input SIM with LEDs
- SIM8-OUT-PNP 8 digital sourcing output SIM with LEDs
- SIM8-OUT-NPN 8 digital sinking output SIM with LEDs
- SIM8-AN-IN 4 +/- 10V analog input SIM
- SIM8-AN-OUT 4 +/- 10V analog 10-bit output SIM
- SIM8-RLY10 8 10 watt reed relay SIM

Cables

- 71-016137-10 10' 6K to Stepper (ZETA, OEM750, S-Drive)
- 71-017003-10 10' 6K to Servo (cut off)
- 71-016949-100 100' expansion I/O cable
- 71-016987-10 Gemini to 6K Servo
- 71-016966-10 Gemini to 6K Stepper

Ship Kit

- 6K-Kit 6K Hardware Installation Guide
- 6K Programmer's Guide
- 6K Command Reference
- Motion Planner CD
- Panel Mounting Hardware
- Crossover Ethernet cable for direct PC to 6K communication only

Example: 6K4-NK
 (a 4-axes controller with no ship kit included and no synchronization bus included.)

*For fieldbus options, please contact your local ATC or call Compumotor.

* EVM32-BASE and SIM cards sold separately. Up to 4 SIM cards fit in each EVM32-BASE.

Dimensions for 6K and EVM32

Dimensions in inches (mm)

6K2 & 6K4

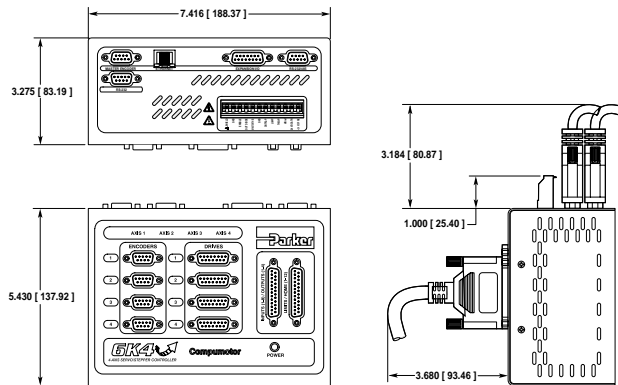

EVM32

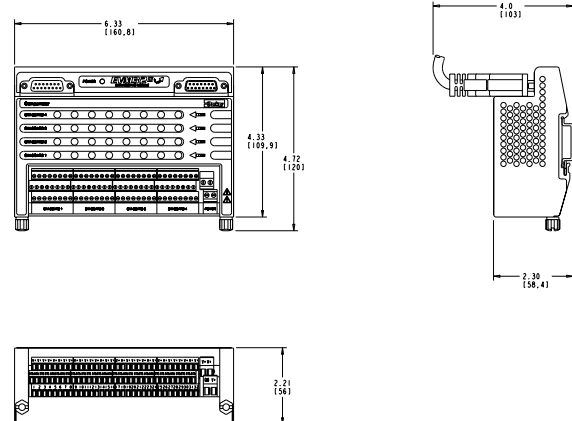

6K6 & 6K8

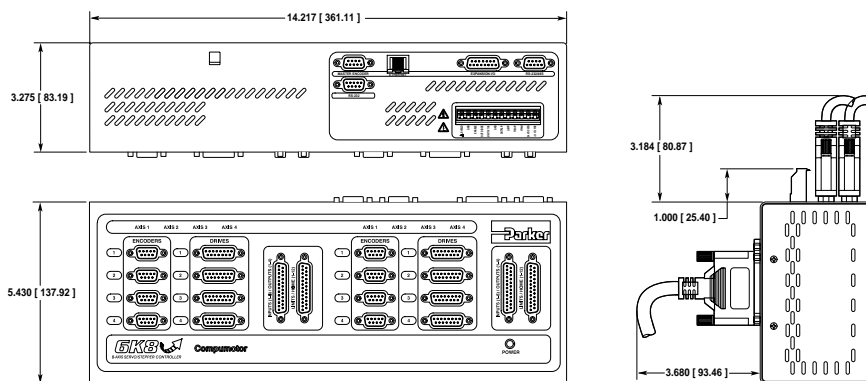

Discover How The 6K Motion Controller Can Solve Your Next Application. Call 1-800-358-9070 Today.