

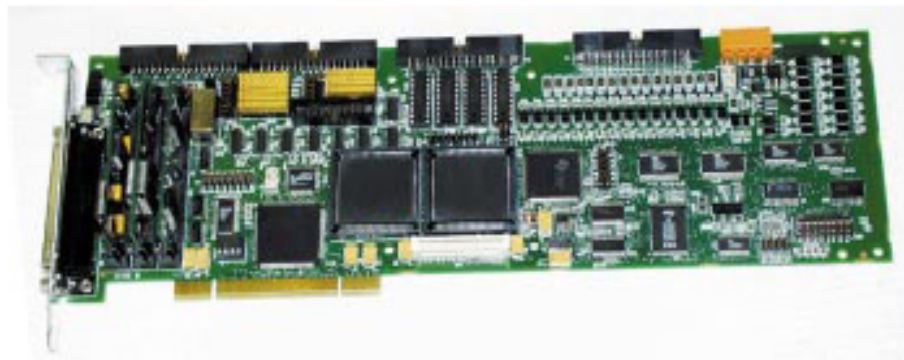

p/n YPM08126

ACR8020 Hardware Manual

Effective: October 7, 2002



This page intentionally left blank.

CHANGE NOTICE

ACR8020 Hardware Manual P/N PM08126 Version Change:

From: Version 1.00, Dated 12/8/2000

To: Version 1.01, Dated 12/8/2001

To: Version 1.02, Dated 1/10/2002

To: Version 1.03, Dated 1/29/2002

1. Page 12, Plug and Play Capability Added Plug and Play information.
2. Page 22, Digital Input Reference Select (JP17 and JP18) Added figure.
3. Page 23, Digital Output Sink/Source Select (JP15 and JP16) Added output driver IC source.
4. Page 24, Digital Output Sink/Source Select (JP15 and JP16) Added figure.
5. Page 38, Serial Communications Corrected MUX table.
6. Page 39, ACRCOMM Module Setup Added figure information.
7. Page 66, Technical Specification Corrected operating temperature range.
8. Page 41, EXPAXIS 9-16 Axis Expansion board Added Chapter
9. Page 13 Fixed ENC number error Moved Chapter 5 to ODD page..

ACR8020 Hardware Manual P/N PM08126 Version Change:

Version 1.02, Dated 1/10/02

- | | | |
|----|--------------------------|-----------------|
| 1. | ACR8020 Hardware Manual | Initial Release |
| 2. | ACR8020 Hardware Manual | Version 1.02 |
| 3. | ACR8020 Hardware Manual. | Version 1.03 |

TABLE OF CONTENTS

INTRODUCTION	7
CHAPTER 1	9
ACR8020 MOTHERBOARD PLUG AND PLAY CAPABILITY	9
CHAPTER 1 OVERVIEW	11
ACR8020 MOTHERBOARD PLUG AND PLAY CAPABILITY	12
<i>Dual Port Memory Address Select</i>	12
<i>Interrupt Select</i>	12
CHAPTER 2	13
ACR8020 MOTHERBOARD HARDWARE SETUP	13
CHAPTER 2 OVERVIEW	15
ACR8020 MOTHERBOARD SWITCHES	17
<i>Serial Communication Card Selection /User Switch (SW1)</i>	17
ACR8020 MOTHERBOARD JUMPERS	18
<i>ACR8020 Jumper Table List</i>	18
<i>Encoder Pull-up Select Jumpers (JP5-JP14)</i>	19
<i>Digital Input Reference Select Jumper (JP17 and JP18)</i>	21
<i>Digital Output Sink / Source Select Jumpers (JP15 and JP16)</i>	23
ACR8020 MOTHERBOARD HARDWARE WIRING	25
<i>Encoder Inputs (P1A, P1B, P1C)</i>	26
<i>Analog Input / Output (P2)</i>	30
<i>Digital Inputs / Outputs (P3 and P4)</i>	31
<i>Miscellaneous Output (P9)</i>	32
<i>Digital I/O Power (PWR1)</i>	33
CHAPTER 3	35
ACRCOMM MODULE HARDWARE SETUP (OPTIONAL)	35
CHAPTER 3 OVERVIEW	37
ACRCOMM SERIAL COMMUNICATIONS	38
ACRCOMM MODULE JUMPERS	40
<i>ACRCOMM Jumper Table List</i>	40
<i>RS-422 Termination Jumpers (J1 thru J4)</i>	41
<i>Battery Enable Jumpers (J5 and J6)</i>	42
<i>Autobaud Detect Jumper (J7)</i>	43
ACRCOMM MODULE HARDWARE WIRING (OPTIONAL)	44
<i>ACRCOMM Standalone Power (PWR2)</i>	45
<i>ACRCOMM Communications (P5)</i>	46
CHAPTER 4	47

EXPAXIS 9-16 AXIS EXPANSION BOARD (OPTIONAL)	47
CHAPTER 4 OVERVIEW	49
EXPAXIS MODULE PLUGS	51
<i>Encoder Inputs (XP1A, XP1B, XP1C)</i>	53
<i>Expaxis Analog Input / Output (DXP2)</i>	57
<i>Expaxis Module Encoder Pullups</i>	58
EXPAXIS MODULE SUGGESTED STACKING	59
EXPAXIS MODULE AIRFLOW	61
EXPAXIS MODULE SOFTWARE	63
CHAPTER 5	65
TECHNICAL SPECIFICATIONS	65
ACR8020 TECHNICAL SPECIFICATION	66
CHAPTER 6	69
ACR8020 MECHANICAL DETAILS	69
ACR8020/ACRCOMM BOARD	70
ACR8020 TYPICAL CONNECTION DIAGRAMS	71

TABLES

Table 2.1	ACR8020 Serial Communication Card Number Select.....	17
Table 2.2	ACR8020 Encoder Pull-Up Jumpers.....	20
Table 2.3	ACR8020 Digital Input Reference Jumper.....	21
Table 2.4	ACR8020 Digital Output Sink/Source Select Jumper.....	23
Table 2.5	ACR8020 Encoder Input Connectors P1A and P1B.....	26
Table 2.6	ACR8020 Encoder Input Connector P1C.....	27
Table 2.7	ACR8020 Analog I/O Connector.....	30
Table 2.8	ACR8020 Digital I/O Connector.....	31
Table 2.9	ACR8020 Miscellaneous Output Connector P9.....	32
Table 2.10	ACR8020 SVCC Power Fuses.....	32
Table 2.11	ACR8020 Isolated Power Connector.....	33
Table 2.12	ACR8020 Isolated Power Fuses.....	33
Table 3.1	ACRCOMM RS-422 Termination Jumpers.....	41
Table 3.2	ACRCOMM Autobaud Detect Jumper.....	43
Table 3.3	ACRCOMM Communications Connector.....	46
Table 4.1	EXPAXIS Module Encoder Pull-Up Jumpers.....	58

FIGURES

Figure 1.	ACR8020 Motherboard Outline	16
Figure 2.	ACR8020 Digital Input User Circuit	22
Figure 4.	ACRCOMM RS-422 Interface Schematic.....	38
Figure 5.	ACRCOMM Module Outline	39
Figure 6	EXPAXIS (9-16) Axis Expansion Board for the ACR8020.....	52
Figure.7	Recommended Stacking for ACR8020 Options.	59

INTRODUCTION

This document provides hardware connection information for the Acroloop ACR8020 motion controller.

WARNING

The ACR8020 board requires that the PC has BOTH 3.3VDC and 5VDC available on the backplane. ATX Style Power Supplies and Backplanes with both 3.3V and 5V are recommended for use. Powering up the board without BOTH 3.3VDC and 5VDC available will permanently damage the ACR8020 board.

Before powering up any ACR8020 board, please verify the required voltages are present.

Included in this document is the hardware connection information for the following optional plug-in modules:

- a. ACRCOMM module. This board is required for serial communication operation of the ACR8020 motion controller. The external power supply input and battery back-up functions provided by this board are not used with the ACR8020 board.

WARNING

Wiring external power to the ACR8020 through the ACRCOMM module will permanently damage the ACR8020 board.

This page intentionally left blank.

CHAPTER 1

ACR8020 MOTHERBOARD PLUG AND PLAY CAPABILITY

This page intentionally left blank.

CHAPTER 1 OVERVIEW

This section contains diagrams of the interrupt and memory decoding capabilities used in the Plug and Play setup of the ACR8020 motherboard.

NOTE: It is important to read the README file located on the Acroloop CD before attempting any PC installation of the ACR8020 board.

ACR8020 MOTHERBOARD PLUG AND PLAY CAPABILITY

Dual Port Memory Address Select

The ACR8020 can receive and transmit data through its Dual Port Memory accessible on the PCI bus. The dual port memory address range is automatically configured in Windows™ via the ACR8020's PCI Plug and Play interface.

Refer to the Acroloop CD for installation instructions and software libraries that support the ACR8020 board.

NOTE: It is important to read the README file located on the Acroloop CD before attempting any PC installation of the ACR8020 board.

Interrupt Select

The ACR8020 can be instructed to interrupt a PC host through the parallel bus by issuing a SET 112 command in immediate mode or from within a program. Interrupt driven software at the host level is an advanced topic and should only be attempted by someone with a thorough knowledge of interrupt driven code.

The interrupt is automatically configured in Windows™ via the ACR8020's PCI Plug and Play interface.

Refer to the Acroloop CD for installation instructions and software libraries that support the ACR8020 board.

NOTE: It is important to read the README file located on the Acroloop CD before attempting any PC installation of the ACR8020 board.

CHAPTER 2

ACR8020 MOTHERBOARD HARDWARE SETUP

This page intentionally left blank.

CHAPTER 2 OVERVIEW

This section contains diagrams of the jumpers and switches on the ACR8020 motherboard.

Encoder pull-up jumpers must be set correctly based on the types of encoders being used. Failure to set these jumpers correctly may cause damage to the encoders or to the receivers on the controller card.

There are no analog adjustment “pots” on the board. All analog gain and offset is under software control. The analog outputs must be wired to differential control signal inputs on a servo amplifier. The DAC SIMM module outputs provide an analog control voltage of ± 10 volts.

Stepper SIMM module outputs provide open-collector step and direction signals. There are no pull-up resistors provided on the Stepper outputs.

Factory default jumper settings for the ACR8020 motherboard are highlighted within the following jumper tables.

ACR8020 MOTHERBOARD HARDWARE SETUP

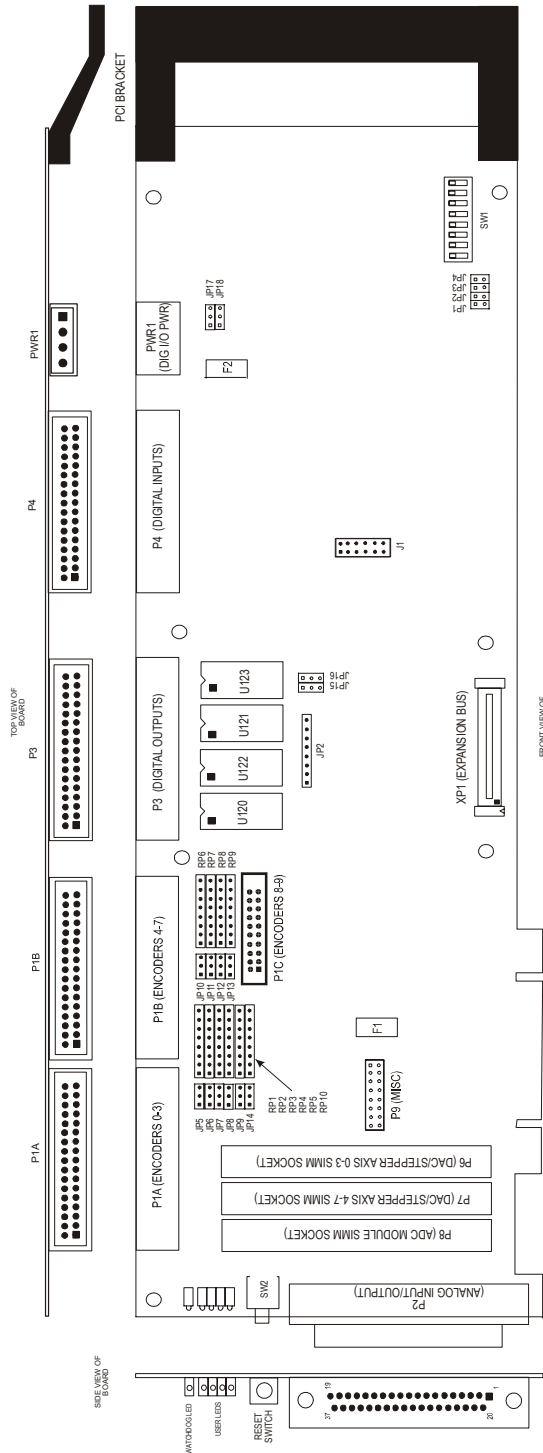

NOTE: Square pin indicates Pin 1.

Figure 1. ACR8020 Motherboard Outline

ACR8020 MOTHERBOARD SWITCHES

Serial Communication Card Selection / User Switch (SW1)

Serial communications via the COM1 and COM2 communication ports on the optional ACRCOMM module are performed with multiple cards using different ACR8020 card numbers. The following table shows how the switch positions 1 through 4 relate to the ACR8020 card number.

Dip switch positions 5 through 8 are used as dedicated user switch inputs. This portion of the switch is available to the user as part of the Miscellaneous Input Flags (bits 68 thru 71). Refer to Appendix B, Flag References.

Refer to Figure 1 for switch location.

Note that Switch 4 should be left in the “OFF” position, unless using the Flash Bypass Mode of operation. Flash Bypass Mode is selected when the user does not want to load the program information from flash at power-up or reset. Serial communications via the COM1 and COM2 communication ports on the ACRCOMM module will recognize the card as Card Number 15. However, the card should be placed back to a valid card number during normal operation.

Refer to Figure 1 for switch location.

Card Number	SW1 Settings				Function
	4	3	2	1	
0	OFF	OFF	OFF	OFF	Serial Communications
1	OFF	OFF	OFF	ON	Serial Communications
2	OFF	OFF	ON	OFF	Serial Communications
3	OFF	OFF	ON	ON	Serial Communications
4	OFF	ON	OFF	OFF	Serial Communications
5	OFF	ON	OFF	ON	Serial Communications
6	OFF	ON	ON	OFF	Serial Communications
7	OFF	ON	ON	ON	Serial Communications
8-14	RESERVED				
15	ON	ON	ON	ON	Flash Bypass Mode

Table 2.1 ACR8020 Serial Communication Card Number Select

ACR8020 MOTHERBOARD JUMPERS

Jumper Table List

The following is a list of the jumper functions on the ACR8020 motherboard:

JUMPER	JUMPER FUNCTION
JP1	Reserved for Future Use
JP2	Reserved for Future Use
JP3	Reserved for Future Use
JP4	Reserved for Factory Test**
JP5	ENC0 Pull-up Voltage Select (Page 19)
JP6	ENC1 Pull-up Voltage Select (Page 19)
JP7	ENC2 Pull-up Voltage Select (Page 19)
JP8	ENC3 Pull-up Voltage Select (Page 19)
JP9	ENC8 Pull-up Voltage Select (Page 19)
JP10	ENC4 Pull-up Voltage Select (Page 19)
JP11	ENC5 Pull-up Voltage Select (Page 19)
JP12	ENC6 Pull-up Voltage Select (Page 19)
JP13	ENC7 Pull-up Voltage Select (Page 19)
JP14	ENC10 Pull-up Voltage Select (Page 19)
JP15	Digital Output Sinking/Sourcing Select (Page 23)
JP16	Digital Output Sinking/Sourcing Select (Page 23)
JP17	Digital Input Sinking/Sourcing Select (Page 21)
JP18	Digital Input Sinking/Sourcing Select (Page 21)
J1	Factory Test Header**
J2	Factory Programming Header**

** Connecting external signals to these headers may cause board failure or damage to IC's.

Refer to Figure 1 for locations.

ACR8020 MOTHERBOARD JUMPERS

Encoder Pull-up Select Jumpers (JP5-JP14)

The ACR8020 is capable of handling various types of incremental open-collector and line driver encoders. Care must be taken to setup each channel to match the encoder type as described below:

The encoder options for the ACR8020 are selectable as follows:

Encoder Options	Encoders Supplied
None	Not Applicable
5	0,1,2,3 and 8
10	0,1,2,3,4,5,6,7 and 8

Open Collector Encoders:

When using open-collector encoders, the encoder channels must be pulled to either +5 or +12 volts, depending upon the application. Pulling up to +12 volts provides higher noise immunity, but causes a slower response time. For high frequency applications (encoder rates higher than 1 megahertz) the +5 volt pull-up section may be necessary.

Line Driver Encoders:

When using line driver (or balanced pair) encoders, the corresponding resistor pack should be removed from it's socket. Leaving the resistor pack in the socket can cause faulty encoder operation and possibly severe encoder damage. Optionally, the resistor pack can be replaced with an 8-pin isolated resistor pack to supply termination resistance for the balanced signal pairs.

Pull-up Selection:

The following table lists the pull-up jumper settings for each encoder:

 WARNING
Wiring a line driver encoder with the pull-up selected to +12 volts will permanently damage the encoder.

ACR8020 MOTHERBOARD JUMPERS

Encoder Pull-up Select Jumpers (JP5-JP14), cont'd

Encoder Pull-Up Jumpers				
Encoder	Resistor	Jumper	+5V	+12V
0	RP1	JP5	1-2	2-3
1	RP2	JP6	1-2	2-3
2	RP3	JP7	1-2	2-3
3	RP4	JP8	1-2	2-3
4	RP6	JP10	1-2	2-3
5	RP7	JP11	1-2	2-3
6	RP8	JP12	1-2	2-3
7	RP9	JP13	1-2	2-3
8	RP5	JP9	1-3	3-5
9	RP10	JP14	2-4	4-6

Table 2.2 ACR8020 Encoder Pull-Up Jumpers

Refer to Figure 1 for jumper location.

ACR8020 MOTHERBOARD JUMPERS

Digital Input Reference Select (JP17 and JP18)

This jumper selects the reference voltage to be used for the optically-isolated inputs. The reference voltage selected applies to all inputs; there are no combinations available.

Isolated voltage (VEXT) refers to +24VDC

WARNING

Wiring VEXT with the incorrect voltage will permanently damage the Digital I/O circuitry. The isolated voltage (VEXT) is selected as +24VDC.

Refer to Figure 1 for jumper location.

Digital Input Reference Jumper				
Input Type	Reference Voltage	JP17	JP18	User Supplies
Sinking	Reference Inputs to +24VDC Isolated Voltage (VEXT)	1-2	1-2	Path to GEXT
Sourcing	Reference Inputs to Isolated Common (GEXT)	2-3	2-3	Path to VEXT

Table 2.3 ACR8020 Digital Input Reference Jumper

ACR8020 MOTHERBOARD JUMPERS

USER CIRCUIT	JUMPER POSITIONS
<p>SINK INPUT</p> 	<p>JP17-1 to JP17-2 JP18-1 to JP18-2</p>
<p>SOURCE INPUT +24VDC Isolated Voltage (VEXT)</p> 	<p>JP17-2 to JP17-3 JP18-2 to JP18-3</p>

Figure 2. ACR8020 Digital Input User Circuit

ACR8020 MOTHERBOARD JUMPERS

Digital Output Sink/Source Select Jumpers (JP15 and JP16)

These jumpers are set at the factory based on the type of the output drivers, IC's U120 through U123. The selected type of the output driver applies to all outputs; there are no combinations available.

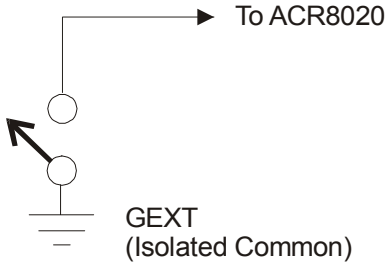
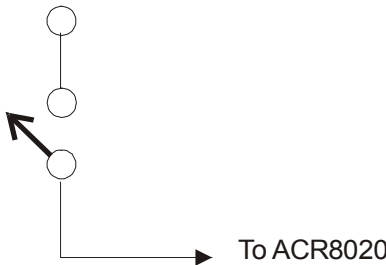
Isolated voltage (VEXT) refers to +24VDC.

WARNING

Wiring VEXT with the incorrect voltage will permanently damage the Digital I/O circuitry. The isolated voltage (VEXT) is +24VDC.

Selecting the wrong jumper settings for the type of output drivers installed on the board will permanently damage the output driver IC's (U120-U123). The output drivers are installed at the factory, based on the Sinking or Sourcing Option selected when ordering the board.

Refer to Figure 1 for jumper location.

Digital Output Sink/Source Select Jumpers				
Output Type	Output Driver IC Type Installed (U120-U123) (See Warning Above)	JP15	JP16	User Supplies
Sink	Motorola / ST Micro ULN2803A	1-2	1-2	Path to VEXT
Source	Allegro UDN2981A	2-3	2-3	Path to GEXT

Table 2.4 ACR8020 Digital Output Sink/Source Select Jumper

ACR8020 MOTHERBOARD JUMPERS

USER CIRCUIT	JUMPER POSITIONS
<p style="text-align: center;">SINK OUTPUT</p> <p style="text-align: center;">+24VDC Isolated Voltage (VEXT)</p>  <p style="text-align: right;">LOAD</p> <p>From ACR8020 »</p>	<p>JP15-1 to JP15-2 JP16-1 to JP16-2</p>
<p style="text-align: center;">SOURCE OUTPUT</p> <p>From ACR8020 »</p>  <p style="text-align: right;">LOAD</p> <p>GEXT (Isolated Common)</p>	<p>JP15-2 to JP15-3 JP16-2 to JP16-3</p>

Figure 3. ACR8020 Digital Output User Circuit

ACR8020 MOTHERBOARD HARDWARE WIRING

This section contains diagrams of the connectors on the ACR8020 motherboard.

Before optically-isolated digital inputs and outputs can be used, the card must be connected to an external +24V DC power supply. This connection is made at the PWR1 connector and is fused on-board at 4 amps to protect the controller card.

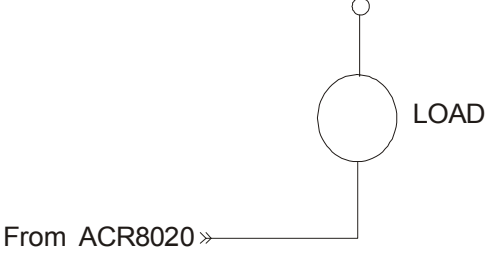
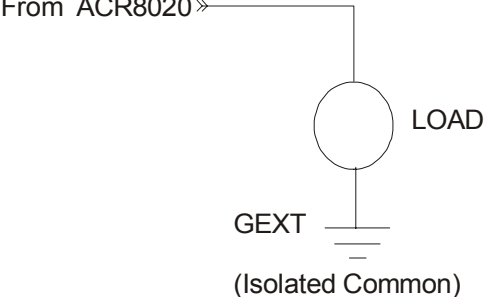
WARNING

Wiring VEXT with the incorrect voltage will permanently damage the Digital I/O circuitry. The isolated voltage (VEXT) is +24VDC.

ACR8020 MOTHERBOARD HARDWARE WIRING

Encoder Inputs (P1A, P1B, P1C)

There are two 34 pin headers and one 20 pin header provided on the ACR8020 for encoder feedback. The two 34 pin header provide up to eight (8) axes of encoder feedback (Encoders 0 thru 7). The 20 pin header provides 2 axes of encoder feedback (Encoder 8 and 9). Refer to Figure 1 for connector location.

Note: P1A and P1B are 34-pin shrouded male headers.

P1A				P1B			
Usage	Pin	Pin	Usage	Usage	Pin	Pin	Usage
CHA0	1	2	CHA0'	CHA4	1	2	CHA4'
CHB0	3	4	CHB0'	CHB4	3	4	CHB4'
MRK0	5	6	MRK0'	MRK4	5	6	MRK4'
VCC	7	8	GND	VCC	7	8	GND
CHA1	9	10	CHA1'	CHA5	9	10	CHA5'
CHB1	11	12	CHB1'	CHB5	11	12	CHB5'
MRK1	13	14	MRK1'	MRK5	13	14	MRK5'
VCC	15	16	GND	VCC	15	16	GND
CHA2	17	18	CHA2'	CHA6	17	18	CHA6'
CHB2	19	20	CHB2'	CHB6	19	20	CHB6'
MRK2	21	22	MRK2'	MRK6	21	22	MRK6'
VCC	23	24	GND	VCC	23	24	GND
CHA3	25	26	CHA3'	CHA7	25	26	CHA7'
CHB3	27	28	CHB3'	CHB7	27	28	CHB7'
MRK3	29	30	MRK3'	MRK7	29	30	MRK7'
VCC	31	32	GND	VCC	31	32	GND
N.C.	33	34	N.C.	N.C.	33	34	N.C.

Table 2.5 ACR8020 Encoder Input Connectors P1A and P1B

ACR8020 MOTHERBOARD HARDWARE WIRING

Encoder Inputs (P1A, P1B, P1C), cont'd.

Note: P1C is a 20-pin shrouded male header.

P1C			
Usage	Pin	Usage	Pin
CHA8	1	MRK8'	2
CHA8'	3	VCC	4
CHB8	5	GND	6
CHB8'	7	N.C.	8
MRK8	9	KEY**	10
CHA9	11	MRK9'	12
CHA9'	13	VCC	14
CHB9	15	GND	16
CHB9'	17	N.C.	18
MRK9	19	N.C.	20

Table 2.6 ACR8020 Encoder Input Connector P1C

NOTE: P1C pin 10 is used as a key pin.

ACR8020 MOTHERBOARD HARDWARE WIRING

Encoder Inputs (P1A, P1B, P1C), cont'd.

P1C is designed to work in conjunction with a 20 pin ribbon cable terminated to two (2) standard 9-pin female D-sub type connectors.

This 12 inch cable, AMCS P/N PWH015, is supplied with the Encoder 8/9 Option.

Ribbon cable conductors 1 thru 9 connect to D-Sub #1 (conductor 10 is a No Connect).
Ribbon cable conductors 11 thru 19 connect to D-Sub #2 (conductor 20 is a No Connect).
When used in this manner, the D-sub pinouts are as follows:

Signal	D-Sub #1
CHA8	1
CHA8'	2
CHB8	3
CHB8'	4
MRK8	5
MRK8'	6
VCC	7
GND	8
No Connect	9

Signal	D-Sub #2
CHA9	1
CHA9'	2
CHB9	3
CHB9'	4
MRK9	5
MRK9'	6
VCC	7
GND	8
No Connect	9

ACR8020 MOTHERBOARD HARDWARE WIRING

Encoder Inputs (P1), Continued

The ACR8020 can accept any feedback device that supplies either a +5V or +12V differential signal to the ACR8020. The most common type of device is a differential encoder. Refer to the table below for common encoder setups.

Encoder Type	ACR8020 Pull-up/Jumper Setting	Length of Cable/Type
Differential Line Driver (+5 Volt Outputs)	Remove Pull-ups	100 ft. (Beldon 9330 Shielded Twisted Pair)
Open Collector Driver (No Pull-ups on Encoder)	Install Pull-ups and Jumper to +12V	75 ft. (Beldon 9330 Shielded Twisted Pair)
Open Collector Driver (With Pull-ups to +5 V on Encoder)	Install Pull-ups and Jumper to +5V	50 ft. (Beldon 9330 Shielded Twisted Pair)
TTL Driver (+5 Volt Outputs)	Remove Pull-ups	50 ft. (Beldon 9330 Shielded Twisted Pair)

When using a single-ended encoder (an encoder without the A-, B-, or Z- outputs), additional pull-ups and pull-down resistors must be added externally to the ACR8020 board in order for the ACR8020 to read the encoder signals. **Warning:** This is not a recommended mode of operation. Noise immunity is significantly reduced.

Refer to the ACR8020 Typical Connection Diagram section of this manual for details on wiring a single-sided encoder to the ACR8020.

ACR8020 MOTHERBOARD HARDWARE WIRING

Analog Input/Output (P2)

The analog input/output connections are made through a 37-pin D-style connector on the side of the ACR8020 motion controller. Refer to Figure 1 for connector location.

Note: P2 is a standard 37-pin female D-plug.
Pin definitions in parentheses are for stepper modules.

P2				Module
Definition	Pin	Pin	Definition	
ASIG-0 (STEP-0)	1	20	AGND-0 (DIR-0)	P6 Module 0 DAC/STEP
ASIG-1 (STEP-1)	2	21	AGND-1 (DIR-1)	
ASIG-2 (STEP-2)	3	22	AGND-2 (DIR-2)	
ASIG-3 (STEP-3)	4	23	AGND-3 (DIR-3)	
ASIG-4 (STEP-4)	5	24	AGND-4 (DIR-4)	P7 Module 1 DAC/STEP
ASIG-5 (STEP-5)	6	25	AGND-5 (DIR-5)	
ASIG-6 (STEP-6)	7	26	AGND-6 (DIR-6)	P8 Module 2 ADC 12 or 16 Bit
ASIG-7 (STEP-7)	8	27	AGND-7 (DIR-7)	
AIN-0	9	28	AIN-1	
AIN-2	10	29	AIN-3	Module0 (P6)
AIN-4	11	30	AIN-5	
AIN-6	12	31	AIN-7	Module1 (P7)
(LCUR-0)	13	32	(LCUR-1)	
(LCUR-2)	14	33	(LCUR-3)	None
(LCUR-4)	15	34	(LCUR-5)	
(LCUR-6)	16	35	(LCUR-7)	Module 2 (P8)
WD-COM	17	36	WD-NO	
WD-COM	18	37	WD-NC	
AGND	19			

Table 2.7 ACR8020 Analog I/O Connector

ACR8020 MOTHERBOARD HARDWARE WIRING

Digital Inputs / Outputs (P3 and P4)

There are two 34 pin headers provided on the ACR8020 for digital I/O interface. The 34 pin headers are used for the 32 Digital Inputs and 32 Digital Outputs. Refer to Figure 1 for connector location.

Note: P3 and P4 are 34-pin shrouded male headers.

P3				P4			
Usage	Pin	Pin	Usage	Usage	Pin	Pin	Usage
OUT-32	1	2	OUT-33	INP-00	1	2	INP-01
OUT-34	3	4	OUT-35	INP-02	3	4	INP-03
OUT-36	5	6	OUT-37	INP-04	5	6	INP-05
OUT-38	7	8	OUT-39	INP-06	7	8	INP-07
OUT-40	9	10	OUT-41	INP-08	9	10	INP-09
OUT-42	11	12	OUT-43	INP-10	11	12	INP-11
OUT-44	13	14	OUT-45	INP-12	13	14	INP-13
OUT-46	15	16	OUT-47	INP-14	15	16	INP-15
OUT-48	17	18	OUT-49	INP-16	17	18	INP-17
OUT-50	19	20	OUT-51	INP-18	19	20	INP-19
OUT-52	21	22	OUT-53	INP-20	21	22	INP-21
OUT-54	23	24	OUT-55	INP-22	23	24	INP-23
OUT-56	25	26	OUT-57	INP-24	25	26	INP-25
OUT-58	27	28	OUT-59	INP-26	27	28	INP-27
OUT-60	29	30	OUT-61	INP-28	29	30	INP-29
OUT-62	31	32	OUT-63	INP-30	31	32	INP-31
VISO	33	34	VISO	GISO	33	34	GISO

Table 2.8 ACR8020 Digital I/O Connector

ACR8020 MOTHERBOARD HARDWARE WIRING

Miscellaneous Output (P9)

A fused +5VDC Stepper Output (SVCC) is available on the P9 connector for use with wiring the Stepper SIMM Module outputs. The maximum recommended output rating for SVCC is 250 milliamps.

Note: P9 is a 16 pin unshrouded male header.

P9			
Usage	Pin	Usage	Pin
SVCC	1	SVCC	2
SVCC	3	SVCC	4
GND	5	GND	6
RESERVED	7	RESERVED	8
RESERVED	9	RESERVED	10
GND	8	GND	12
N.C.	13	N.C.	14
N.C.	15	N.C.	16

Table 2.9 ACR8020 Miscellaneous Output Connector P9

See Figure 1 for fuse F5 location.

Stepper +5VDC Output Fuse			
Fuse	Circuit	Amps	Littelfuse Part No.
F1	SVCC	0.500	154.500

Table 2.10 ACR8020 SVCC Power Fuses

ACR8020 MOTHERBOARD HARDWARE WIRING

Digital I/O Power (PWR1)

PWR1 is the connection for the user supplied voltage for the Digital Inputs and Digital Outputs and should be wired to VEXT as shown in the table below. Refer to Figure 1 for connector location.

Isolated voltage (VEXT) refers to +24VDC.

 WARNING
Wiring VEXT with the incorrect voltage will permanently damage the Digital I/O circuitry. The isolated voltage (VEXT) is +24VDC.

Note: PWR1 is a 4-pin male Weidmuller plug.

PWR1 Isolated Power Connector	
Usage	Pin
Isolated Common (GEXT)	1
Isolated Common (GEXT)	2
Isolated Voltage (VEXT)	3
Isolated Voltage (VEXT)	4

Table 2.11 ACR8020 Isolated Power Connector

Isolated Power Fuse			
Fuse	Circuit	Amps	Littelfuse Part No.
F2	VEXT	4	154.004

Table 2.12 ACR8020 Isolated Power Fuses

This page intentionally left blank.

CHAPTER 3

ACRCOMM MODULE HARDWARE SETUP (OPTIONAL)

This page intentionally left blank.

CHAPTER 3 OVERVIEW

The ACRCOMM Plug-In Module provides serial communication ports (2 serial, 1 parallel) capability for the ACR8020 motherboard. ACRCOMM external power input and User-SRAM battery back-up functions are not used with the ACR8020 motherboard. These circuits are not populated on the ACR8020 COMM Board.

This section contains diagrams of the jumpers and switches on the ACRCOMM module.

Factory default jumper settings for the ACRCOMM module are highlighted within the following jumper tables.

ACRCOMM SERIAL COMMUNICATIONS

The ACR8020 serial communication interface is software configurable. At power-up, the default COM1/COM2 communications mode is RS-232. For ACR8020 boards with the communications option, the serial ports may be configured as above via a serial port, or at power-up (or any time) via the PCI bus communications port.

The following tables show the configuration schemes for the ACR8020 board with the serial communication ACRCOMM module option. Refer to the User's Guide manual, COM1/COM2 Stream Flags, Appendix B, for bit flag details.

MUX Flags, Set-up communication type flags:

MUX1 FLAG	MUX0 FLAG	COMM FUNCTION
CLR (0)	CLR (0)	Not Used
CLR (0)	SET (1)	RS-232 (Default)
SET (1)	CLR (0)	RS-422
SET (1)	SET (1)	Not Used

RECEIVE/TRANSMIT Flags, RS-422 flow control flags:

RECEIVE FLAG	TRANSMIT FLAG	COMM FUNCTION
CLR (0)	CLR (0)	Not Used (Default)
CLR (0)	SET (1)	Use for RS-422 Operation: Full Duplex Receiver Enabled Transmitter Enabled
CLR (0)	CLR (0)	Not Used
CLR (0)	SET (1)	Not Used
SET (1)	Don't Care	Not Used

RS-422 INTERFACE SCHEMATIC

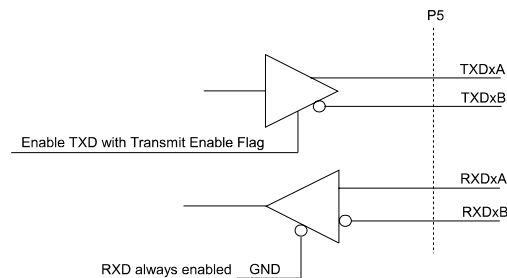
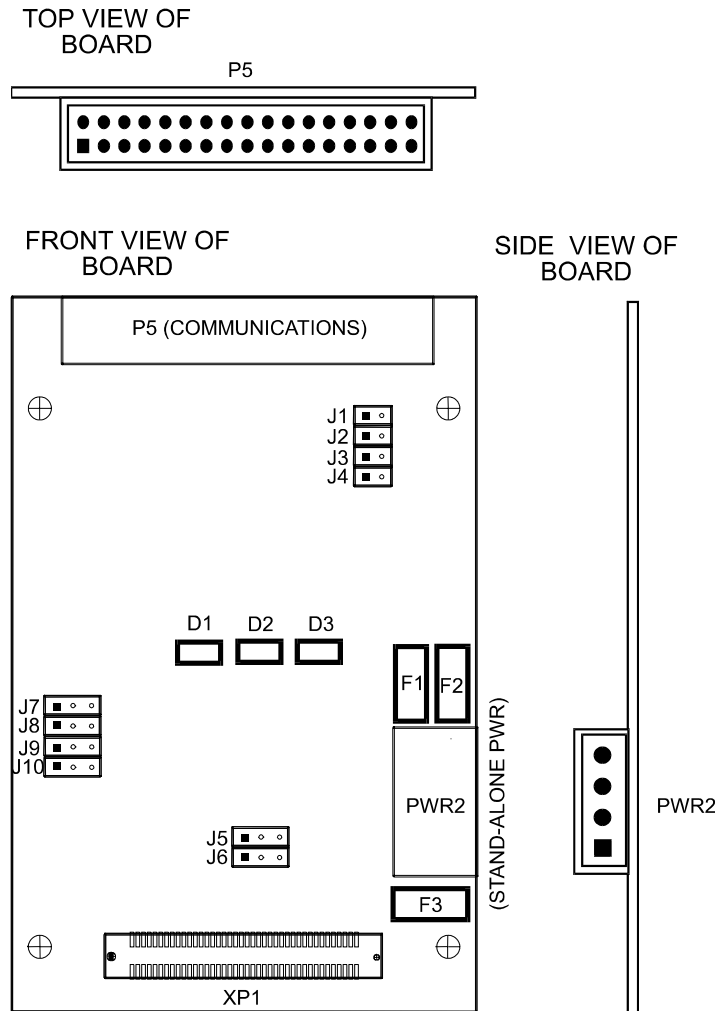

Figure 4. ACRCOMM RS-422 Interface Schematic

ACRCOMM MODULE HARDWARE SETUP (OPTIONAL)



NOTE: Square pin indicates Pin 1.

Items F1, F2, F3, and PWR2 shown above are not populated on the ACR8020 COMM Module.

Figure 5. ACRCOMM Module Outline

ACRCOMM MODULE JUMPERS

Jumper Table List

The following is a list of the jumper functions on the ACRCOMM module:

JUMPER	JUMPER FUNCTION
J1	COM1 RS-422 Termination Resistor Select (Page 41)
J2	COM1 RS-422 Termination Resistor Select (Page 41)
J3	COM2 RS-422 Termination Resistor Select (Page 41)
J4	COM2 RS-422 Termination Resistor Select (Page p)
J5	Not Used with the ACR8020
J6	Not Used with the ACR8020
J7	COM1 and COM2 Autobaud Detect Enable (Page 43)
J8	Reserved
J9	Reserved
J10	Reserved

ACRCOMM MODULE JUMPERS (OPTIONAL)

RS-422 Communication Ports Line Terminator Jumpers (J1 thru J4)

These jumpers provide termination resistors for the RS-422 signals.

Communication Ports Termination Jumpers			
Signal	Jumper	Termination	No Termination
RXD1A/RXD1B	J1	Jumper In	Jumper Out
TXD1A/TXD1B	J2	Jumper In	Jumper Out
RXD2A/RXD2B	J3	Jumper In	Jumper Out
TXD2A/TXD2B	J4	Jumper In	Jumper Out

Table 3.1 ACRCOMM RS-422 Termination Jumpers

Refer to Figure 5 for jumper location.

ACRCOMM MODULE JUMPERS (OPTIONAL)

Battery Enable Jumpers (J5 and J6)

Not used with the ACR8020 Motherboard.

ACRCOMM MODULE JUMPERS (OPTIONAL)

Autobaud Detect Jumper (J7)

This jumper enables or disables the autobaud detect feature of the serial communications channels on the ACRCOMM module. This jumper works in conjunction with the COM1 Startup Mode (P7013) and COM2 Startup Mode (P7029) parameters listed in the Acroloop Motion Controller's User's Guide under Miscellaneous Parameters P6912-P7029.

When the Startup Enable bit is not set (0 - default) in the COM1/2 Startup Mode parameters, the jumper is ignored and Autobaud detect is always enabled. The default operation of the COM1 and COM2 ports is Autobaud Detect enabled.

When the Startup Enable bit is set (1) in the COM1/2 Startup Mode parameters, the jumper defines the Autobaud Detect function as listed in the following table.

Autobaud Detect Jumper	
Function	J7
Autobaud Detect Enabled	ON
Autobaud Detect Disabled	OFF

Table 3.2 ACRCOMM Autobaud Detect Jumper

Refer to Figure 5 for jumper location.

ACRCOMM MODULE HARDWARE WIRING (OPTIONAL)

This section contains diagrams of the connectors on the ACRCOMM module.

ACRCOMM MODULE HARDWARE WIRING (OPTIONAL)

Standalone Power (PWR2)

Not used with the ACR8020 Mother board. All fuses and PWR2 connector are removed to prevent accidental power application to the ACRCOMM board.



WARNING

Wiring external power to the ACR8020 through the ACRCOMM module will permanently damage the ACR8020 board.

ACRCOMM MODULE HARDWARE WIRING (OPTIONAL)

Communications (P5)

There is one 34 pin header provided on the ACRCOMM communications board for the 2 serial and 1 parallel communications ports. The two serial ports, COM1 and COM2, can be individually configured as RS-232 or RS-422 interfaces. Configuration of the COM ports is software selectable by the user.

The following diagram shows the connections for the 3 communications ports. Refer to Figure 4 for connector location.

Note: P5 is a 34-pin shrouded male header.

P5			
Usage	Pin	Usage	Pin
RXD1	1	TXD1	2
GND	3	MUX1	4
TXD1A	5	TXD1B	6
RXD1A	7	RXD1B	8
RXD2	9	TXD2	10
GND	11	MUX2	12
TXD2A	13	TXD2B	14
RXD2A	15	RXD2B	16
STB	17	AFD	18
ERR	19	INIT	20
SLIN	21	GND	22
PD0	23	PD1	24
PD2	25	PD3	26
PD4	27	PD5	28
PD6	29	PD7	30
ACK	31	BUSY	32
PE	33	SLCT	34

Table 3.3 ACRCOMM Communications Connector

CHAPTER 4

EXPAXIS 9-16 Axis Expansion Board. (OPTIONAL)

This page intentionally left blank.

CHAPTER 4 OVERVIEW

The EXPAXIS Plug-In Module provides additional axes support to the base ACR8020. A maximum of 8 Axes (Stepper or Servo) and up to 10 Encoders are available. Additionally, either of the 12 Bit or the 16 Bit ADC option can be added to this board.

So, with the fully loaded EXPAXIS option, an ACR8020 can have up to 16 Servo/Stepper Outputs, 20 Incremental Encoders, 16 Single Ended (8 Differential) ADC Channels.

Plugs on the EXPAXIS board for ENCODERS, DAC/STEPPER and ADC most part follow the same arrangement as the main ACR8020 board. Factory default jumper settings for the EXPAXIS module are the same as the corresponding jumpers on the main ACR8020 board.

EXPAXIS MODULE PLUGS (OPTIONAL)

The EXPAXIS module has the following plugs:

- XP1A For ENC10,11,12,13 (Corresponds to plug P1A on the main ACR8020 Board).
- XP1B For ENC14,15,16,17 (Corresponds to plug P1B on the main ACR8020 Board).
- XP1C For ENC18,19 (Corresponds to plug P1C on the main ACR8020 Board).
- XP9 For Stepper power and ground. (Corresponds to plug P9 on the main ACR8020 board.)
- XP10 For High speed interrupt (INTCAP) inputs. There is no corresponding plug on the main board. This plug has EXP-IN0...EXP-IN7 TTL inputs to correspond to INP0...INP7 on the main board . Note that unlike the 24Volt logic INP0...INP7, EXP-IN0...EXP-IN7 are TTL logic only.
- XP2 For DAC/STEPPER/ADC I/O. (Corresponds to plug P2 on the main ACR8020 board. Note that P2 on the main board is a D-PLUG whereas XP2 on the EXPAXIS module is a 0.1" Center header. To make the XP2 pin out match P2, the customer must use a ribbon cable #PWH80500 assembly. This assemble takes the XP2 plug and converts it to the DXP2 plug which is plug compatible with the P2 plug on the main board (NOTE: There is no watchdog relay on the EXPAXIS module. So the DXP2 plug does not have the watchdog signals wired!). User must therefore use the watchdog safety contacts from the P2 plug for safeguarding the machine.

EXPAXIS HARDWARE WIRING

Encoder Inputs (XP1A, XP1B, XP1C)

There are two 34 pin headers and one 20 pin header provided on the EXPAXIS (similar to the base ACR8020) for encoder feedback. The two 34 pin header provide up to eight (8) axes of encoder feedback (Encoders 10 thru 17). The 20 pin header provides 2 axes of encoder feedback (Encoder 18 and 19). Refer to Figure 6 for connector location.

Note: XP1A and XP1B are 34-pin shrouded male headers.

XP1A				XP1B			
Usage	Pin	Pin	Usage	Usage	Pin	Pin	Usage
CHA10	1	2	CHA10'	CHA14	1	2	CHA14'
CHB10	3	4	CHB10'	CHB14	3	4	CHB14'
MRK10	5	6	MRK10'	MRK14	5	6	MRK14'
VCC	7	8	GND	VCC	7	8	GND
CHA11	9	10	CHA11'	CHA15	9	10	CHA15'
CHB11	11	12	CHB11'	CHB15	11	12	CHB15'
MRK11	13	14	MRK11'	MRK15	13	14	MRK15'
VCC	15	16	GND	VCC	15	16	GND
CHA12	17	18	CHA12'	CHA16	17	18	CHA16'
CHB12	19	20	CHB12'	CHB16	19	20	CHB16'
MRK12	21	22	MRK12'	MRK16	21	22	MRK16'
VCC	23	24	GND	VCC	23	24	GND
CHA13	25	26	CHA13'	CHA17	25	26	CHA17'
CHB13	27	28	CHB13'	CHB17	27	28	CHB17'
MRK13	29	30	MRK13'	MRK17	29	30	MRK17'
VCC	31	32	GND	VCC	31	32	GND
N.C.	33	34	N.C.	N.C.	33	34	N.C.

Table 4.1 EXPAXIS Encoder Input Connectors XP1A and XP1B

EXPAXIS HARDWARE WIRING

Encoder Inputs (XP1A, XP1B, XP1C), cont'd.

Note: XP1C is a 20-pin shrouded male header.

XP1C			
Usage	Pin	Usage	Pin
CHA18	1	MRK18'	2
CHA18'	3	VCC	4
CHB18	5	GND	6
CHB18'	7	N.C.	8
MRK18	9	KEY**	10
CHA19	11	MRK19'	12
CHA19'	13	VCC	14
CHB19	15	GND	16
CHB19'	17	N.C.	18
MRK19	19	N.C.	20

Table 4.2 EXPAXIS Encoder Input Connector XP1C

NOTE: P1C pin 10 is used as a key pin.

EXPAXIS HARDWARE WIRING

Encoder Inputs (XP1A, XP1B, XP1C), cont'd.

XP1C is designed to work in conjunction with a 20 pin ribbon cable terminated to two (2) standard 9-pin female D-sub type connectors.

This 12 inch cable, AMCS P/N PWH015, is supplied with the Encoder 18/19 Option.

Ribbon cable conductors 1 thru 9 connect to D-Sub #1 (conductor 10 is a No Connect).
Ribbon cable conductors 11 thru 19 connect to D-Sub #2 (conductor 20 is a No Connect).
When used in this manner, the D-sub pinouts are as follows:

Signal	D-Sub #1
CHA18	1
CHA18'	2
CHB18	3
CHB18'	4
MRK18	5
MRK18'	6
VCC	7
GND	8
No Connect	9

Signal	D-Sub #2
CHA19	1
CHA19'	2
CHB19	3
CHB19'	4
MRK19	5
MRK19'	6
VCC	7
GND	8
No Connect	9

EXPAXIS HARDWARE WIRING

Encoder Inputs (XP1), Continued

The ACR8020 can accept any feedback device that supplies either a +5V or +12V differential signal to the ACR8020. The most common type of device is a differential encoder. Refer to the table below for common encoder setups.

Encoder Type	EXPAXIS Pull-up/Jumper Setting	Length of Cable/Type
Differential Line Driver (+5 Volt Outputs)	Remove Pull-ups	100 ft. (Beldon 9330 Shielded Twisted Pair)
Open Collector Driver (No Pull-ups on Encoder)	Install Pull-ups and Jumper to +12V	75 ft. (Beldon 9330 Shielded Twisted Pair)
Open Collector Driver (With Pull-ups to +5 V on Encoder)	Install Pull-ups and Jumper to +5V	50 ft. (Beldon 9330 Shielded Twisted Pair)
TTL Driver (+5 Volt Outputs)	Remove Pull-ups	50 ft. (Beldon 9330 Shielded Twisted Pair)

When using a single-ended encoder (an encoder without the A-, B-, or Z- outputs), additional pull-ups and pull-down resistors must be added externally to the ACR8020 board in order for the ACR8020 to read the encoder signals. **Warning:** This is not a recommended mode of operation. Noise immunity is significantly reduced.

Refer to the ACR8020 Typical Connection Diagram section of this manual for details on wiring a single-sided encoder to the ACR8020.

EXPAXIS HARDWARE WIRING

Analog Input/Output (DXP2)

The analog input/output connections on the EXPAXIS module is a 40 Pin Header. From this header a ribbon cable assembly (#PWH80500) is provided that converts the 40 pin header signals to a 37 Pin D-Plug signals to plug labeled DXP2. This plug is pin compatible to the P2 connector on the main ACR8020 board with the exception of the watchdog relay signals. This is because only the main ACR8020 board has the watchdog relay. Refer to Figure 6 for connector location.

Note: DXP2 is a standard 37-pin female D-plug.
Pin definitions in parentheses are for stepper modules.

DXP2				Module
Definition	Pin	Pin	Definition	
ASIG-8 (STEP-8)	1	20	AGND-8 (DIR-8)	Module 0
ASIG-9 (STEP-9)	2	21	AGND-9 (DIR-9)	
ASIG-10 (STEP-10)	3	22	AGND-10 (DIR-10)	Module 1
ASIG-11 (STEP-11)	4	23	AGND-11 (DIR-11)	
ASIG-12 (STEP-12)	5	24	AGND-12 (DIR-12)	
ASIG-13 (STEP-13)	6	25	AGND-13 (DIR-13)	Module 2
ASIG-14 (STEP-14)	7	26	AGND-14 (DIR-14)	
ASIG-15 (STEP-15)	8	27	AGND-15 (DIR-15)	Module0
AIN-8	9	28	AIN-9	
AIN-10	10	29	AIN-11	Module1
AIN-12	11	30	AIN-13	
AIN-14	12	31	AIN-15	None
(LCUR-8)	13	32	(LCUR-9)	
(LCUR-10)	14	33	(LCUR-11)	Module 2
(LCUR-12)	15	34	(LCUR-13)	
(LCUR-14)	16	35	(LCUR-15)	
	17	36		
	18	37		
AGND	19			

Table 4.3 EXPAXIS Analog I/O Cable (#PWH80500) Connector DXP2.

EXPAXIS MODULE ENCODER PULLUPS (OPTIONAL)

Encoder Pull-Up Jumpers				
Encoder	Resistor	Jumper	+5V	+12V
10	RP1	JP1	1-2	2-3
11	RP2	JP2	1-2	2-3
12	RP3	JP3	1-2	2-3
13	RP4	JP4	1-2	2-3
14	RP6	JP6	1-2	2-3
15	RP7	JP7	1-2	2-3
16	RP8	JP8	1-2	2-3
17	RP9	JP9	1-2	2-3
18	RP5	JP5	1-2	2-3
19	RP10	JP10	1-2	2-3

Table 4.1 EXPAXIS Module Encoder Pull-Up Jumpers

EXPAXIS MODULE SUGGESTED STACKING (OPTIONAL)

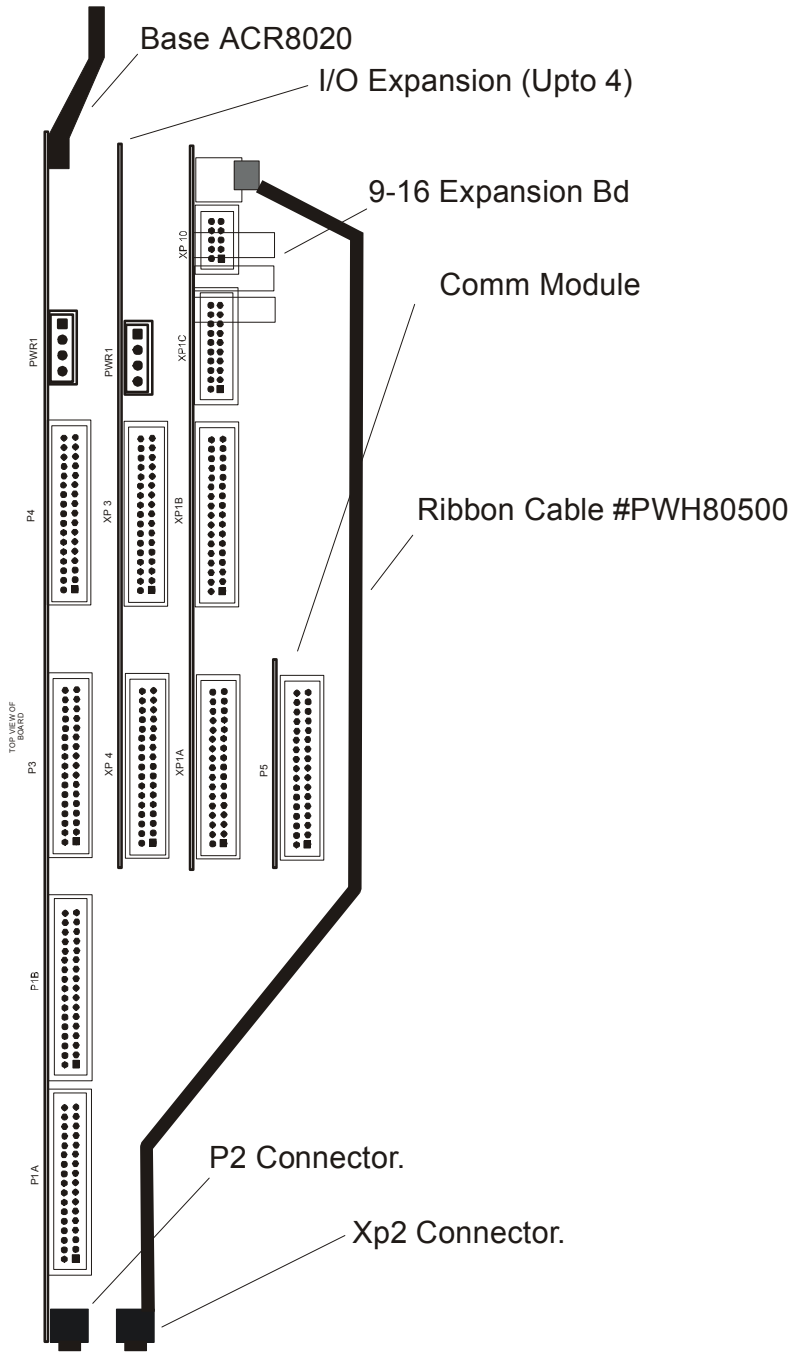

Figure.7 Recommended Stacking for ACR8020 Options.

EXPAXIS MODULE AIRFLOW CONSIDERATIONS.

Acroloop hardware must be kept below 120 degrees F ambient at all times. As more options are added, user must ensure that there are no hot spots being created in the board stack due to airflow impairment. This impairment might be a result of cables coming in the way or lack of fan direction towards the stack. In any case, the temperature must be recorded in several places (specially around I/O and DSP locations) to ensure even heat flow. Failure to do so might cause malfunctions and eventually lead to permanent loss of function.

EXPAXIS MODULE SOFTWARE (OPTIONAL)

In order to use the EXPAXIS option on the ACR8020, software versions 1.18.06 Update 21 and above must be used.

Please refer to the software manual to know what commands are to be used to access axes 9 through 16.

Acroview Vesion 3.11 and higher will also be able to display the extra parameters and show and program axes 9 through 16.

CHAPTER 5

TECHNICAL SPECIFICATIONS

ACR8020 TECHNICAL SPECIFICATION

ITEM	SPECIFICATION
CPU:	32 Bit Floating Point DSP
Processor Type:	Texas Instruments TMS320VC33
Board Size:	2 Slots 13.3" x 4.2" Full-Size PCI Form Factor
Axis Configuration:	2, 4, 6,8 axes configurations on main board 10,12,14,16 Axes configuration with EXPAXIS module option.
Weight:	PC Version: TBF
Operating Temperature:	0°C to 50°C (32°F to 122°F)
Humidity:	0 to 95%, Non-Condensing
Power Consumption:	+3.3VDC +/-0.2VDC @ 2A +5 VDC +/- 0.2VDC @ 2A +12 VDC +/- 0.5VDC @ 0.150 Amps -12 VDC +/- 0.5VDC @ 0.150 Amps Note: Power consumption does not include any additional power required for external components (Encoders, Stepper Outputs, etc.). Note: Power consumption does not include adder cards like I/O, Comm Module or EXPAXIS (Axis9...16) Module
Encoder Inputs:	Up to 10 per card (20 with EXPAXIS Module Option) Differential Quadrature Encoder Open-Collector or Line Driver 0.1 Hz to 20 MHz Frequency Range 100mA maximum power source per channel
DAC/Stepper Outputs:	Up to 8 per card (16 with EXPAXIS Module Option) DAC Outputs: +/- 10VDC @ 5mA, maximum Programmable Output (DAC GAIN, DAC OFFSET) 16 Bit Resolution Single Ended input amplifiers can be used if caution is used to avoid ground loops. Stepper Outputs: Open-Collector Step, Direction, and Low Current Outputs (no pull-up resistors on-board); Fused +5VDC Stepper Output available on P9 connector up to 250 mA. Step Output Frequency : 0 to 6 KHz, pulse width 167us 6 KHz to 4 MHz, approx. 50% duty cycle

ACR8020 TECHNICAL SPECIFICATION, continued

ITEM	SPECIFICATION
Feedback Types:	Any Differential 5VDC or 12VDC including: <ul style="list-style-type: none">- Quadrature Encoder- Glass Scales- Analog (Optional)
Watchdog Relay:	+24VDC @ 1.0 A Single Pole – Double Throw (SPDT) Hardwire through P2 analog header
External I/O Power Supply Requirements:	+24 VDC (+3/-6VDC) @ 4A
Digital Inputs:	32 Optically Isolated (standard) @ External Voltage Supplied Sinking or Sourcing Available Activates on 10mA per input
Digital Outputs:	32 Optically Isolated (standard) @ External Voltage Supplied Output Loads: 32 Outputs @ 50 mA continuously, each or Up to 12 Outputs @ 125mA continuously, each, distributed across the four (4) output drivers, as follows: <ul style="list-style-type: none">up to 3 between OUT32 and OUT39up to 3 between OUT40 and OUT47up to 3 between OUT48 and OUT55up to 3 between OUT56 and OUT63 Open Collector Sinking or Sourcing Type Available
A/D Inputs (SIMM Board Option):	Up to 8 single-ended or up to 4 differential 12 Bit or 16 Bit resolution Configurable for various analog inputs 9 microsecond conversion time Extra 8 Single ended or up to 4 Differential 12 Bit or 16 Bit resolution Inputs can be added with the addition of the EXPAXIS Module Option.
Communications:	PC-Bus standard COM1, COM2, and LPT available on optional ACRCOMM module Simultaneous communications on all 4 ports
Serial Communications: (ACRCOMM Module)	2 ports standard (COM1, COM2) Software Configurable RS-232 or RS-422 Automatic Baud Detect (300 Hz - 38.4 KHz)

This page intentionally left blank.

CHAPTER 6

ACR8020 MECHANICAL DETAILS

ACR8020/ACRCOMM BOARD

The ACR8020 board is a full-size PCI board. When installed in a PC, the board uses two (2) PCI slots (with or without an ACRCOMM module).

ACR8020 TYPICAL CONNECTION DIAGRAMS

Refer to the typical connection drawing file, ACR8020 TYPICAL CONNECTIONS.PDF, supplied separately on the AMCS CD P/N CD2000 under the \DOCS directory.