

PERMANENT MAGNET D.C. SERVOMOTORS



| Parameter | Symbol | Units | MT 2230 | MT 2250 | MT30 F4-25 | MT30 M4-38 | MT30 U4-36 | MT30 U4-57 | MT40 W4-68 |
|---------------------------------|------------|------------------------|------------|------------|---------------|---------------|---------------|---------------|---------------|
| Continuous Torque (stall) | T C | in/lb | 10(oz) | 50(oz) | 13 | 26 | 40 | 40 | 75 |
| Continuous Line Current | I C | amps RMS | 1.2 | 5.5 | 6.5 | 8.6 | 13.2 | 8.3 | 14.0 |
| Maximum Speed | N max | RPM | 5000 | 5000 | 4000 | 3700 | 4000 | 2500 | 2650 |
| Peak Torque | Tp | in/lb | 65(oz) | 360(oz) | 66 | 124 | 195 | 195 | 440 |
| Peak Line Current | Ip | amps RMS | 6.5 | 36 | 34 | 47 | 75 | 47 | 86 |
| Theoretical Acceleration | α m | rad/sec ² | 43333 | 55385 | 6250 | 8235 | 9565 | 9565 | 4717 |
| Torque Sensitivity | KT | in/lb/amp RMS | 10(oz) | 10(oz) | 2.0 | 3.1 | 3.0 | 4.8 | 5.4 |
| Voltage Constant (Line to Line) | Kv | V/KRPM | 7.4 | 7.4 | 25 | 38 | 36 | 57 | 68 |
| Max. Line to Line Volts | V max | Volts DC | 40 | 40 | 100 | 141 | 144 | 142 | 180 |
| DC Res. @ 25°C (Line to Line) | RM | Ohms | 3.1 | 0.9 | 1.0 | 0.82 | 0.45 | 1.1 | 0.27 |
| Inductance (Line to Line) | LM | mh | 3.7 | 2.5 | 5.0 | 6.5 | 3.3 | 8.1 | 3.3 |
| Time Constant Mech | TM | msec | - | - | 5.0 | 6.0 | 5.0 | 5.0 | 5.5 |
| Time Constant Elec | TE | msec | 1.2 | 2.8 | 25 | 15 | 13 | 10 | 17.0 |
| Rotor Inertia | JM | in/lb/sec ² | .0015(oz) | .0065(oz) | .011 | .015 | .020 | .020 | .094 |
| Weight | Wt | lb | 26(oz) | 56(oz) | 12 | 16 | 20 | 20 | 47 |
| Static Friction | TF | in/lb | 2.87(oz) | 3.0(oz) | 1.3 | 1.3 | 1.8 | 1.8 | 2.0 |
| Thermal Insulation Class | - | - | 200 °C | 200 °C | F | F | F | F | F |
| Max. Ambient Temp. | °C | °C | - | - | 40 | 40 | 40 | 40 | 40 |
| Thermal Time Constant | - | Minutes +10% | 15 | 30 | 40 | 50 | 60 | 60 | 100 |

**MT2200 Series Motors
 NEMA 23 Size**

**Performance Curves
 and
 Dimensions**

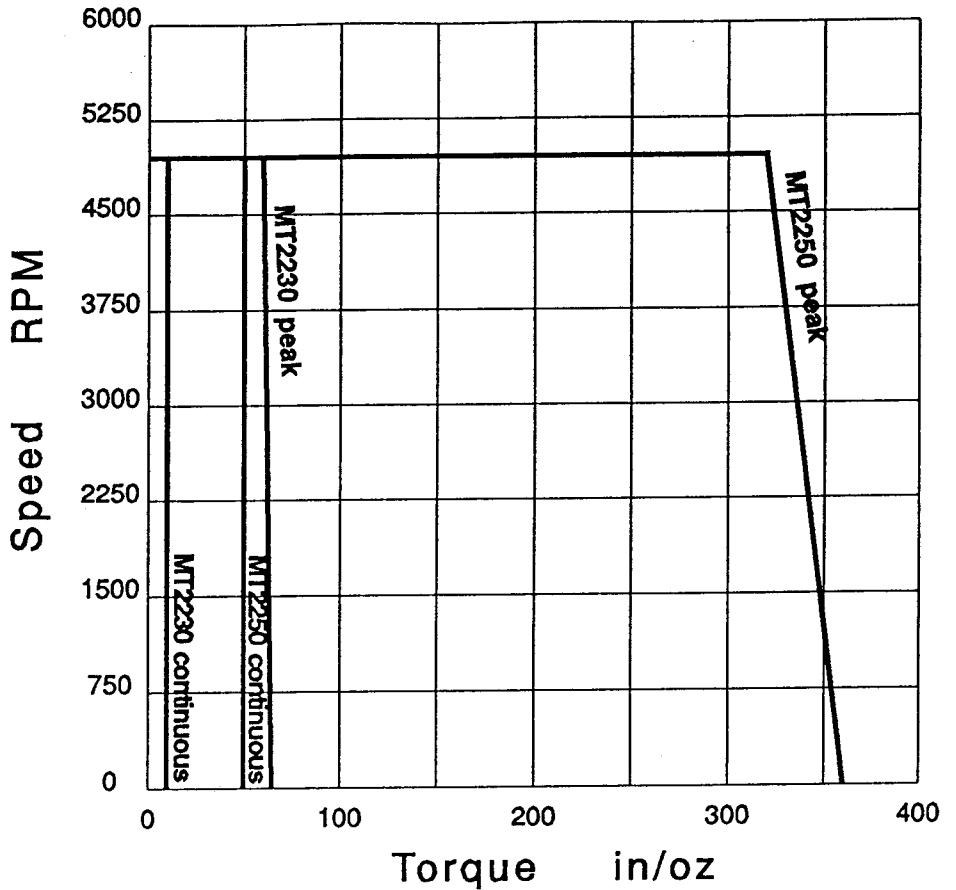

All dimensions are in inches

| | Lm | Llc |
|--------|-----|------|
| MT2230 | 4.6 | 7.75 |
| MT2250 | 6.6 | 9.75 |

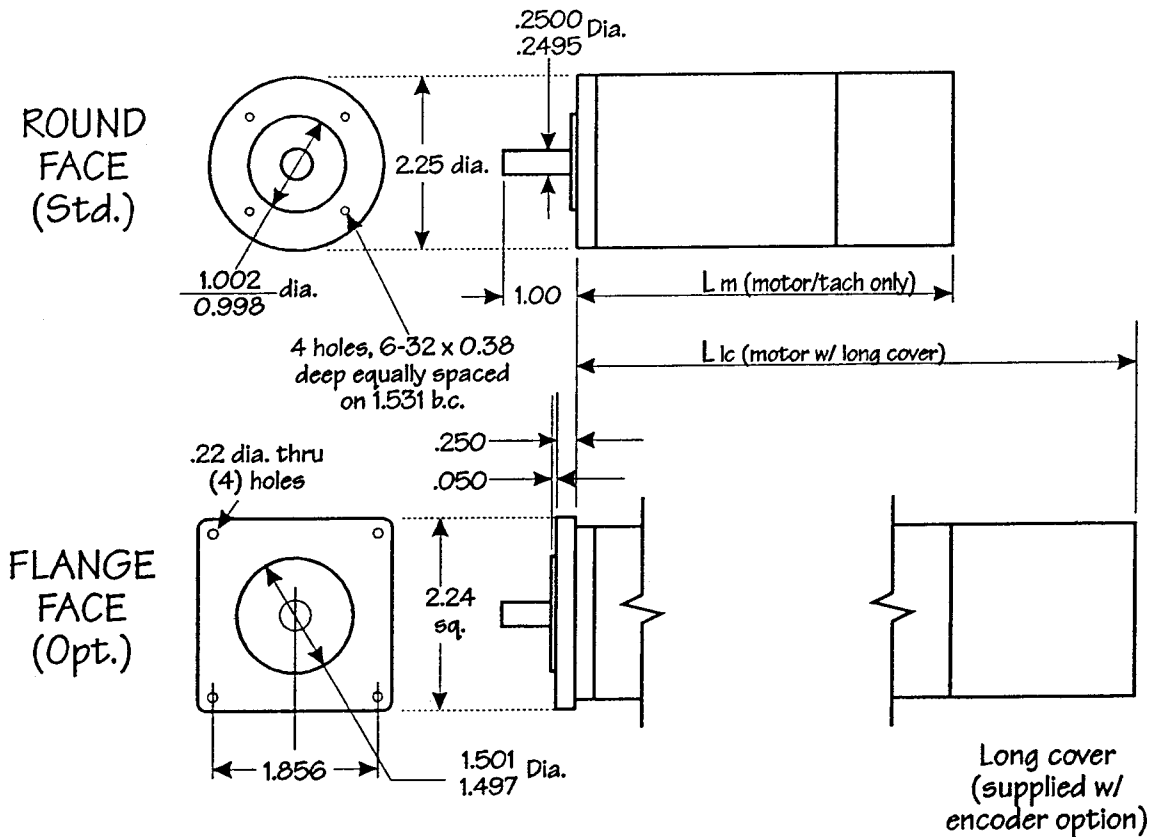

MT30 Series Motors

Performance Curves and Dimensions

All dimensions are in inches

LENGTH TABLE

| | Lm | Lsc | Llc |
|-----------|-------|-------|-------|
| F4 | 7.70 | 8.65 | 11.13 |
| M4 | 9.25 | 10.20 | 12.68 |
| U4 | 11.00 | 11.95 | 14.43 |

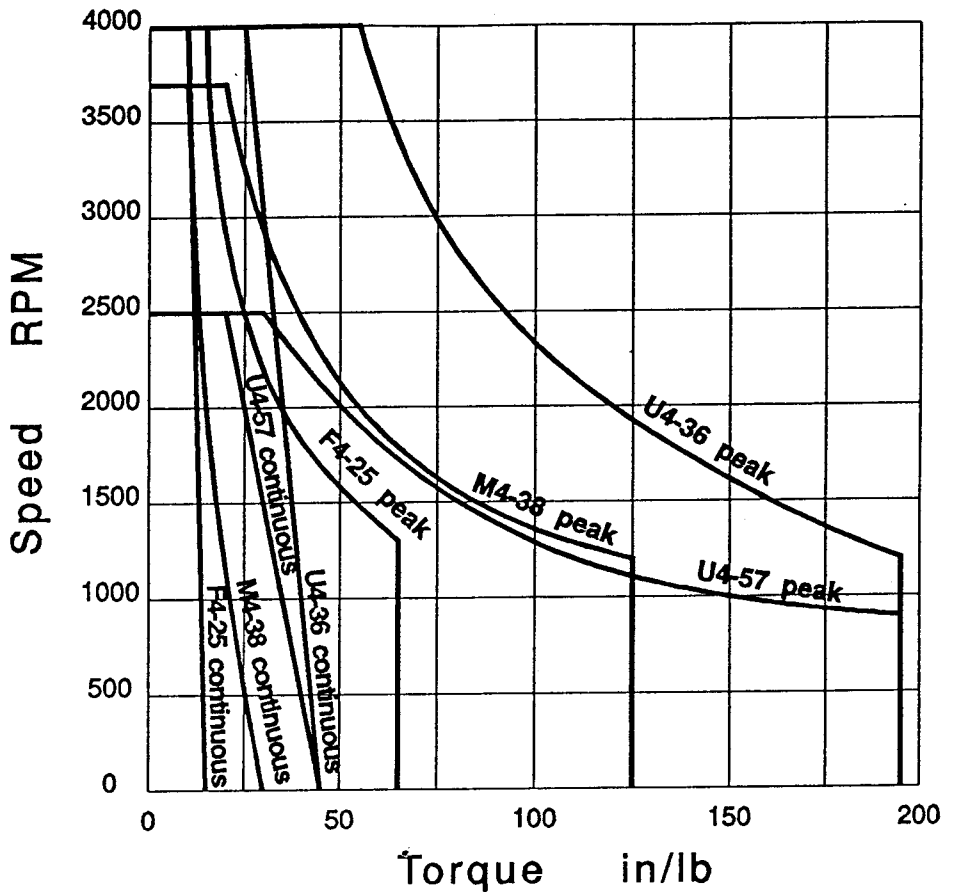

ROUND FACE

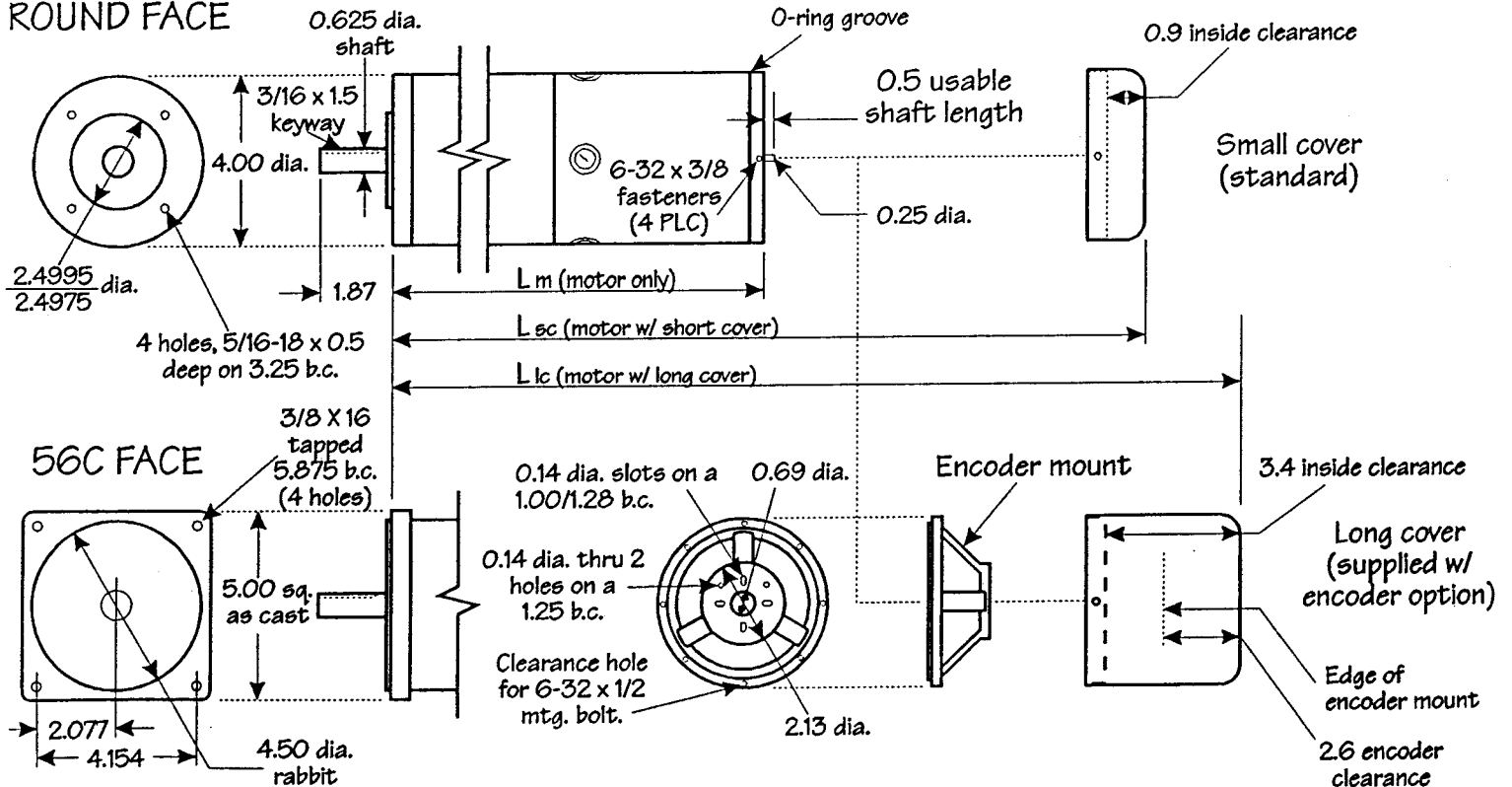

MT40W4-68 Motor

**Performance Curves
and
Dimensions**

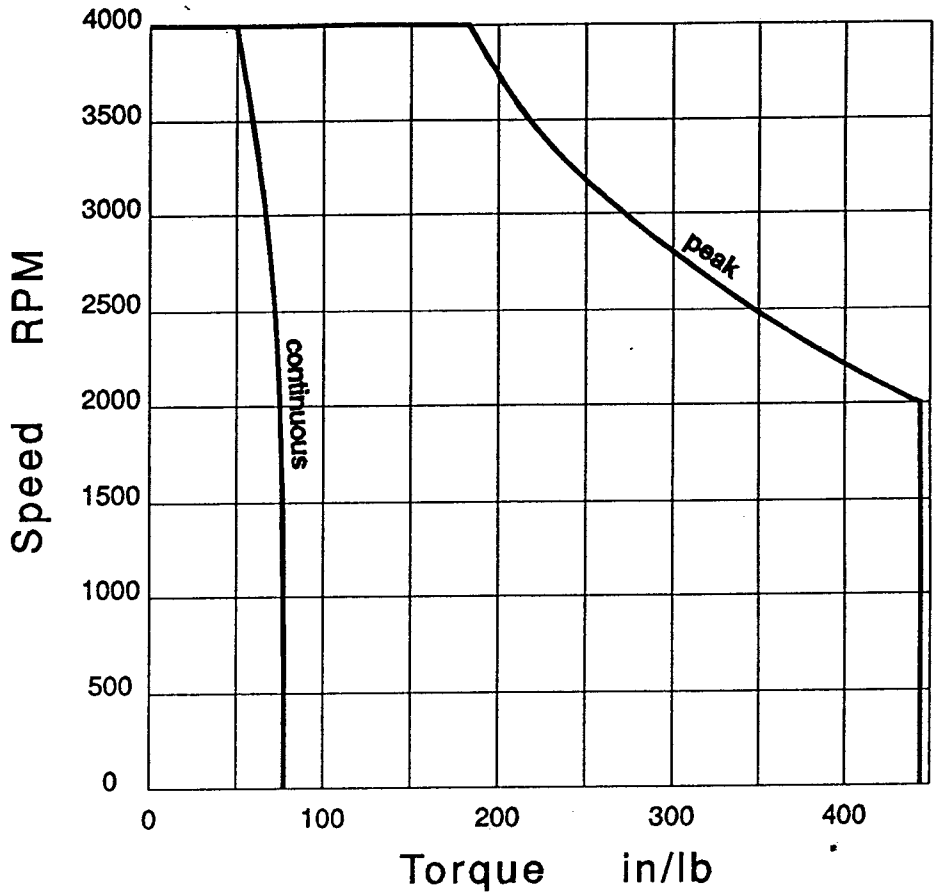

All dimensions are in inches

