

Compumotor

ZETA4-240 Drive User Guide

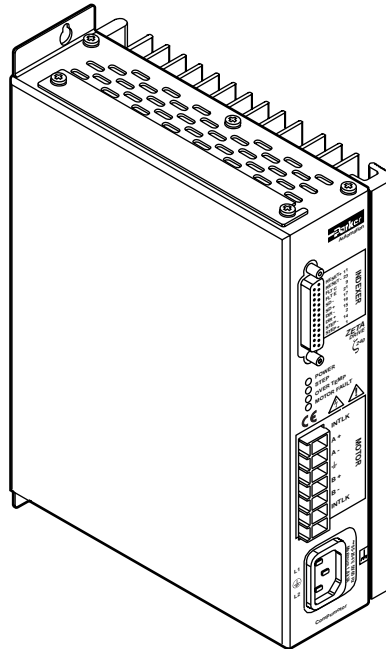

Compumotor Division
Parker Hannifin Corporation
p/n 88-015027-01 A



IMPORTANT

User Information

To ensure that the equipment described in this user guide, as well as all the equipment connected to and used with it, operates satisfactorily and safely, all applicable local and national codes that apply to installing and operating the equipment must be followed. Since codes can vary geographically and can change with time, it is the user's responsibility to identify and comply with the applicable standards and codes. **WARNING: Failure to comply with applicable codes and standards can result in damage to equipment and/or serious injury to personnel.**

Personnel who are to install and operate the equipment should study this user guide and all referenced documentation prior to installation and/or operation of the equipment.

In no event will the provider of the equipment be liable for any incidental, consequential, or special damages of any kind or nature whatsoever, including but not limited to lost profits arising from or in any way connected with the use of this user guide or the equipment.

© *Compumotor Division of Parker Hannifin Corporation, 1997*
— *All Rights Reserved* —

The information in this user guide, including any apparatus, methods, techniques, and concepts described herein, are the proprietary property of Parker Compumotor or its licensors, and may not be copied, disclosed, or used for any purpose not expressly authorized by the owner thereof.

Since Parker Compumotor constantly strives to improve all of its products, we reserve the right to change this user guide and equipment mentioned therein at any time without notice.

Technical Assistance Contact your local automation technology center (ATC) or distributor, or ...

North America and Asia:

Compumotor Division of Parker Hannifin
5500 Business Park Drive
Rohnert Park, CA 94928
Telephone: (800) 358-9070
Fax: (707) 584-3793
FaxBack: (800) 936-6939
BBS: (707) 584-4059
e-mail: tech_help@cmotor.com

Europe (non-German speaking):

Parker Digiplan
21 Balena Close
Poole, Dorset
England BH17 7DX
Telephone: 0202-690911
Fax: 0202-600820

Germany, Austria, Switzerland:

HAUSER Elektronik GmbH
Postfach: 77607-1720
Robert-Bosch-Str. 22 • D-77656 Offenburg
Telephone: (0781) 509-0
Fax: (0781) 509-176



Compumotor Division

Table of Contents

CHAPTER 1 – INTRODUCTION	1
ZETA4-240 DRIVE – DESCRIPTION	2
DIP SWITCHES	2
INPUT & OUTPUT	3
ROTARY SWITCHES	3
POTENTIOMETERS	3
DAMPING TECHNOLOGIES IN THE ZETA4-240 DRIVE	3
THE ZETA4-240 NAME	4
R SERIES MOTORS	4
CHAPTER 2 – INSTALLATION	5
WHAT YOU SHOULD HAVE (SHIP KIT)	6
PRECAUTIONS	6
INSTALLATION OVERVIEW	6
PRE-INSTALLATION	8
1 – SELECT A MOTOR (MOTOR DIMENSIONS)	8
2 – CHOOSE SERIES OR PARALLEL MOTOR WIRING	10
3 – QUICK TEST	13
INSTALLATION	15
1 – SET DIP SWITCHES	15
2 – CONNECT AN INDEXER – INPUTS & OUTPUTS	19
3 – MATCH THE DRIVE TO THE MOTOR	22
4 – MOUNT THE DRIVE (DRIVE DIMENSIONS)	24
5 – MOUNT THE MOTOR	25
6 – CONNECT THE MOTOR TO THE LOAD – COUPLERS	27
7 – CONNECT AC POWER	28
8 – TEST THE INSTALLATION	29
9 – RESONANCE, RINGING AND DAMPING – DISCUSSION AND THEORY	29
10 – DAMPING IN THE ZETA4-240 DRIVE	31
ANTI-RESONANCE	32
ACTIVE DAMPING	33
ELECTRONIC VISCOSITY (EV)	33
11 – SET ROTARY SWITCHES TO ZERO	34
12 – CONFIGURE ACTIVE DAMPING	34
13 – CONFIGURE ELECTRONIC VISCOSITY (EV)	36
14 – RECORD YOUR SYSTEM’S CONFIGURATION INFORMATION	37
CHAPTER 3 – TROUBLESHOOTING	39
TROUBLESHOOTING BASICS	40
DIAGNOSTIC LEDs	40
PROTECTIVE CIRCUITS	40
AUTOMATIC TEST	41
ANTI-RESONANCE DISABLE	41
TECHNICAL SUPPORT	41
PRODUCT RETURN PROCEDURE	42
APPENDIX A – USING NON-COMPUMOTOR MOTORS	43
APPENDIX B – LVD AND EMC INSTALLATION GUIDE	49
APPENDIX C – 120VAC OPERATION	59
INDEX	67



Product Type: ZETA4-240 Stepper Drive

The above product is in compliance with the requirements of directives

- 89/336/EEC Electromagnetic Compatibility Directive
as amended by Directive 92/31/EEC

The product is intended for use in the Commercial, Light Industrial and Industrial Environments as defined in the relevant EMC standards.

This product is compliant with the Low Voltage Directive.

- 72/23/EEC Low Voltage Directive
- 93/68/EEC CE Marking Directive

The ZETA4-240 Drive, when installed according to the instructions in this user guide, and particularly in *Appendix B, LVD and EMC Installation Guide*, has been shown to comply with the Electromagnetic Compatibility Directive (EMC) and the Low Voltage Directive (LVD) of the European Community. If you do not follow these instructions, the operation and protection of the product may be impaired.

CHAPTER ONE

Introduction

IN THIS CHAPTER

- ZETA4-240 Drive Description
 - Anti-Resonance
 - Active Damping
 - Electronic Viscosity
-

ZETA4-240 DRIVE – DESCRIPTION

The ZETA4-240 Drive is a microstepping drive that runs two-phase step motors. It operates directly from 240VAC power; no separate DC power supply or transformer is required.

A typical system is shown below.

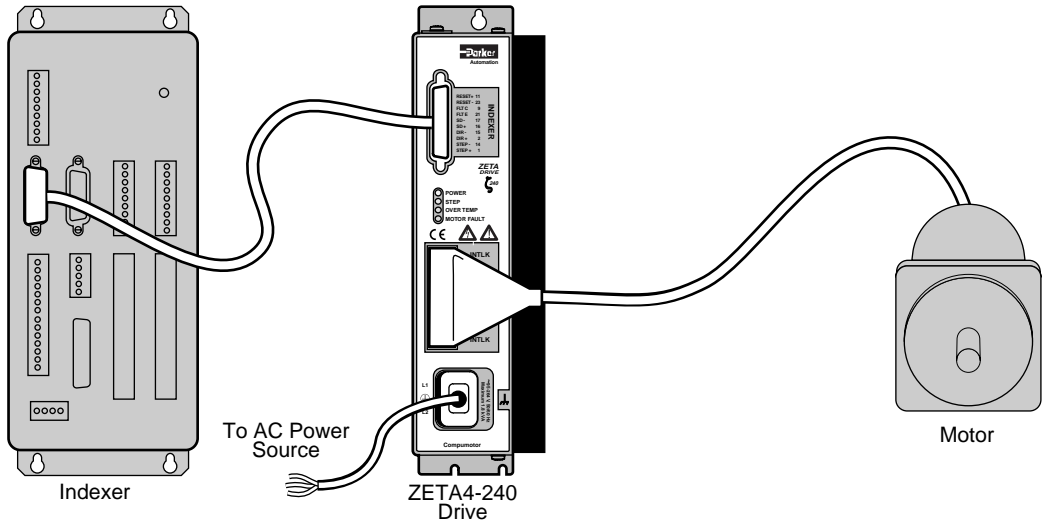

System Components

The indexer sends step and direction signals to the drive. For each step pulse it receives, the drive will commutate the motor to increment rotor position. This is shown in the next drawing.

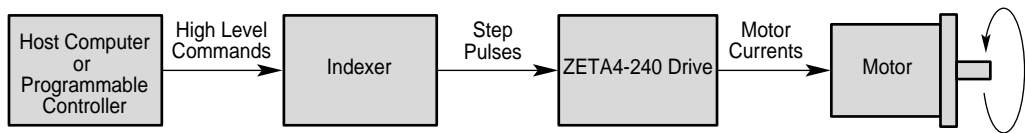

Block Diagram of ZETA4-240 System

The host computer or programmable controller may or may not be necessary, depending upon the indexer's capabilities.

The motor can be wired in series or parallel; the amount of current the drive sends to the motor is set by DIP switches.

DIP SWITCHES

DIP switches are located on top of the ZETA4-240 Drive, behind a removable metal cover. During the installation procedure, the user sets these DIP switches to scale the drive for motor current, resolution, waveform, and other functions.

INPUT & OUTPUT

All communications with the indexer take place through the ZETA4-240 Drive's 25-pin D-connector. Available inputs and outputs are:

- Step Input
- Direction Input
- Shutdown Input
- Fault Output
- Reset Input
- Clockwise/Counterclockwise Input

ROTARY SWITCHES

Two rotary switches are located on top of the ZETA4-240 Drive, next to the DIP switches. The rotary switches are used to adjust the drive's active damping and electronic viscosity circuits.

POTENTIOMETERS

Three potentiometers are located on top of the ZETA4-240 Drive, next to the rotary and DIP switches. The potentiometers are used to adjust the drive's electrical characteristics to match the motor's individual characteristics.

DAMPING TECHNOLOGIES IN THE ZETA4-240 DRIVE

All step motors are subject to resonance, and to ringing after quick transient moves. The ZETA4-240 Drive has three unique circuits that can damp resonance and ringing.

ANTI-RESONANCE

This is a general purpose damping circuit that provides aggressive and effective damping. The user sets DIP switches to choose one of two ranges, based upon system resonant frequency and inertia.

ACTIVE DAMPING

This is an extremely powerful damping circuit. The user sets seven DIP switches and one rotary switch on the drive, to optimize active damping for a specific motor and load.

Anti-resonance and active damping work at speeds greater than three revolutions per second.

ELECTRONIC VISCOSITY (EV)

This circuit provides damping at speeds from rest up to three revolutions per second. The user sets one rotary switch on the drive, to optimize EV for a particular application. EV can reduce settling time at the end of a move, which can lead to increased machine throughput.

THE ZETA4-240 NAME

In the equation that describes the transfer function of a step motor, the Greek symbol ζ (zeta) is used to represent the damping ratio. Because our drive has such sophisticated and unique damping capabilities, we decided to name it the *ZETA4-240 Drive*.

R SERIES MOTORS

R Series motors are available from Compumotor for use with the ZETA4-240 Drive. These motors are designed to match the drive's high performance capabilities.

COMPUMOTOR FAMILY OF PRODUCTS

The ZETA4-240 Drive is completely compatible with Compumotor's broad range of microstepper indexers (single-axis and multi-axis) and motion control products.

CHAPTER TWO

Installation

IN THIS CHAPTER

- Product Ship Kit List
 - Motor Selection and Wiring
 - Quick Test
 - Drive Configuration – DIP Switches, I/O, Potentiometers
 - Mounting the Drive and Motor; Attaching the Load
 - Testing the Installation
 - Active Damping and Electronic Viscosity – Configuration
-

WHAT YOU SHOULD HAVE (*SHIP KIT*)

If you ordered a ZETA4-240 Drive, you should have:

Part	Part Number
ZETA4-240 Drive	ZETA4-240
240VAC Power Connector	43-011905-01
Motor Connector – 7 pin, with jumper installed	71-016155-01
Boot for Motor Connector	58-016135-01
ZETA4-240 Drive User Guide	88-015027-01

You may have ordered one of the following options:

Part	Part Number	
R Series Motor	RS31C- <i>nnnnn</i>	RS42C- <i>nnnnn</i>
	RS32C- <i>nnnnn</i>	RE42C- <i>nnnnn</i>
	RS33C- <i>nnnnn</i>	RS43C- <i>nnnnn</i>
Cable Kit for LVD/EMC Installation	C10	
EMC Kit for LVD/EMC Installation	ZETA EMC SHIPKIT	

PRECAUTIONS

To prevent injuries to personnel and damage to equipment, observe the following guidelines.

- Never probe the drive. Hazardous voltages are present within the drive.
- Never open the drive. Opening the drive will void the warranty.
- Never increase the current setting to a value greater than that specified for the motor you are using. Excessive current may cause motor overheating and failure.

INSTALLATION OVERVIEW

Topics in this chapter are arranged to lead you through the installation process in a step-by-step manner. Complete each step before proceeding to the next.

The order of topics in the installation procedure is:

- Motor selection—specifications, speed/torque curves, and dimensions
- Motor wiring—series vs. parallel
- Quick Test
- DIP switch configuration
- Indexer connections and 25 pin D-connector input/output schematic
- Drive/Motor matching procedure
- Drive mounting
- Motor mounting
- Connecting the load
- Connecting AC power
- Testing the installation
- Resonance, ringing, and damping – discussion and theory
- Active Damping and Anti-Resonance configuration
- Electronic Viscosity configuration

INSTALLATION PROCEDURE

In the following installation procedure, we assume you are using a Compumotor R Series motor and operating your ZETA4-240 Drive at 240VAC. If you do not use an R motor, consult *Appendix A, Using Non-Compumotor Motors*. For LVD/EMC, consult *Appendix B, LVD and EMC Installation Guide*. For 120VAC information, consult *Appendix C, 120VAC Operations*.

The next drawing shows locations and names of the various components that you will encounter during the installation procedure.

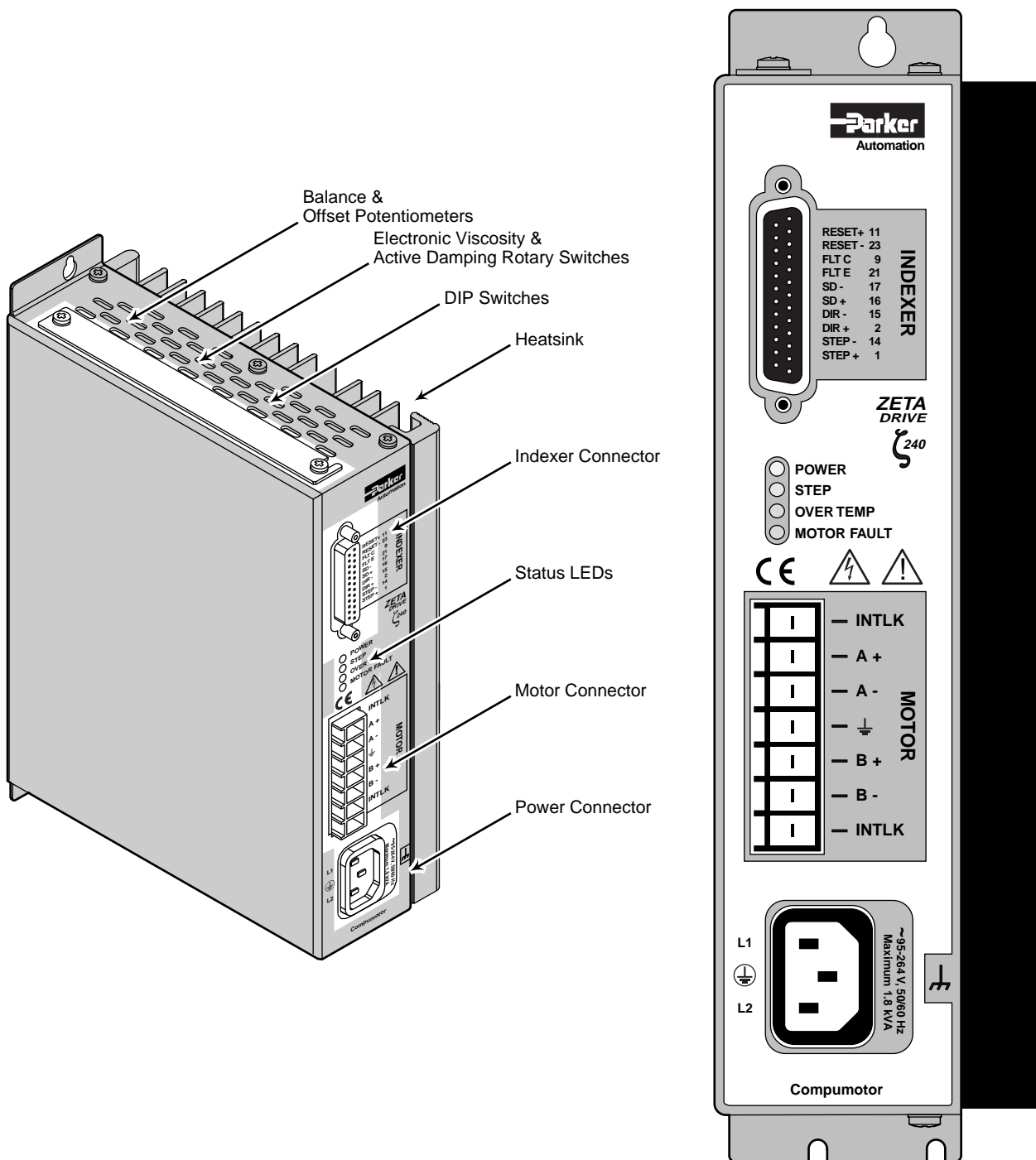

Component Locations

PRE-INSTALLATION

This section explains steps to take before you permanently install your system—selecting a motor, wiring it for series or parallel motor current, and performing a quick test.

We assume you will operate your ZETA4-240 Drive at 240VAC. For 120VAC information, follow instructions in this chapter, and also consult *Appendix C, 120VAC Operations* for additional instructions, and information about Compumotor O and R Motors with 120V windings.

1 – SELECT A MOTOR

We recommend that you use a Compumotor R Motor (with 240V “C” windings) with your ZETA4-240 Drive. Because the R Motor’s materials, design, and construction are matched to the drive’s high performance capabilities, it will operate more efficiently than other motors. Furthermore, the drive’s special features—anti-resonance, active damping, and electronic viscosity—were optimized to work best with R Motors. These features will be most effective if you use an R Motor.

Speed/Torque curves, specifications, and motor dimensions for R Motors are shown below. (See Appendix C for similar information about O and R motors with 120V “B” windings.)

SPEED/TORQUE CURVES

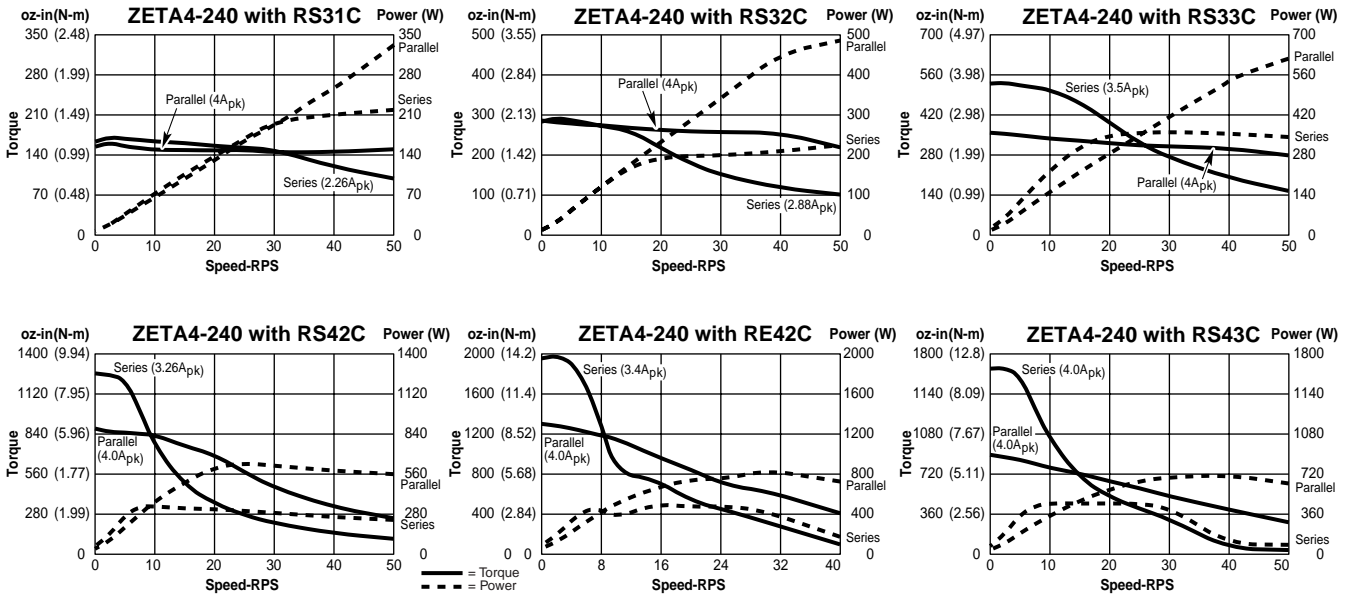

Note 1: Parallel connected motors are limited to 50% duty cycle when operated above 5 rps. For greater than 50% duty cycle above 5 rps, you must connect the motor in series. Fan cooling the motor will increase duty cycles above 5 rps.

Note 2: Viscous damper is not required to achieve speed torque curves.

Note 3: ±10% torque variance due to motor tolerance .

Speed/Torque Curves for R Motors with ZETA4-240 Drive

R SERIES MOTOR SPECIFICATIONS

	Size 34			Size 42		
	RS31C	RS32C	RS33C	RS42C	RE42C	RS43C
Static torque						
oz-in	171	292	532	1,266	1,959	1,671
(N-m)	(1.21)	(2.06)	(3.76)	(8.94)	(13.8)	(11.8)
Rotor inertia						
oz-in ²	3.226	6.561	9.623	61.73	61.73	92.62
(kg-cm ²)	(.59)	(1.2)	(1.8)	(11.29)	(11.29)	(16.94)
Drive Current Apk (Arms)						
Series	2.26 (1.6)	2.88 (2.0)	3.5 (2.5)	3.26 (2.3)	3.4 (2.4)	4.0 (2.8)
Parallel	4.0 (2.8)	4.0 (2.8)	4.0 (2.8)	4.0 (2.8)	4.0 (2.8)	4.0 (2.8)
Phase Inductance (mH)						
Series	17.4	26.2	23.3	65.4	55.6	42.9
Parallel	4.3	6.5	5.8	16.4	13.9	10.7
Detent Torque						
oz-in	8.8	18.0	27.0	50.0	81.0	71.0
(kg-cm ²)	0.062	0.130	0.190	(0.350)	(0.570)	(0.500)
Bearings – Thrust load						
lb	180	180	180	400	400	400
(kg)	(81.6)	(81.6)	(81.6)	(182)	(182)	(182)
Bearings – Radial load						
lb	35	35	35	140	140	140
(kg)	(15.9)	(15.9)	(15.9)	(63.6)	(63.6)	(63.6)
Bearings – End play (Reversing load Equal to 1 lb)						
in	0.001	0.001	0.001	0.001	0.001	0.001
(mm)	(0.025)	(0.025)	(0.025)	(0.025)	(0.025)	(0.025)
Bearings – Radial play (Per 0.5 lb load)						
in	0.0008	0.0008	0.0008	0.0008	0.0008	0.0008
(mm)	(0.02)	(0.02)	(0.02)	(0.02)	(0.02)	(0.02)
Motor Weight						
lb	3.2	5.3	7.6	18.2	18.2	25.7
(kg)	(1.45)	(2.41)	(3.45)	(8.26)	(8.26)	(11.66)
Certifications						
UL recognized	yes	yes	yes	yes	yes	yes
CE (LVD)	yes	yes	yes	yes	yes	yes
CE (EMC & LVD)	*	*	*	*	*	*

*EMC is achievable with C10 Cable Kit and EMC Kit

MOTOR DIMENSIONS

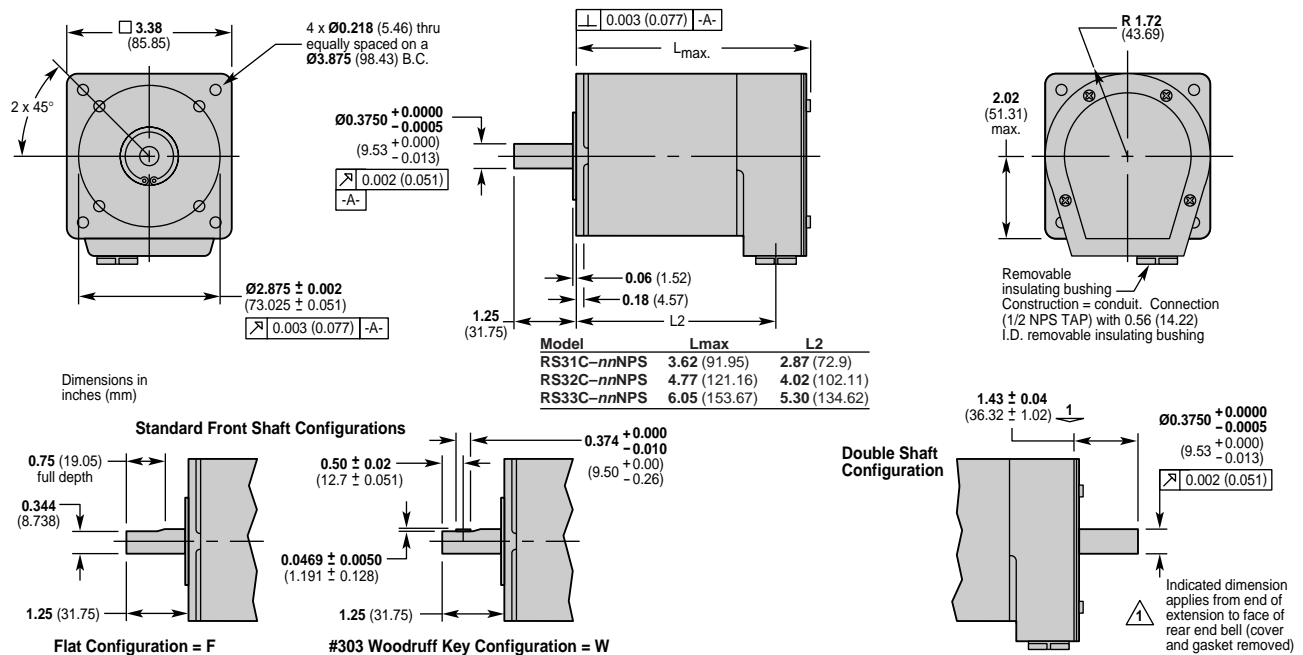

R Motors – Frame Size 34 Dimensions

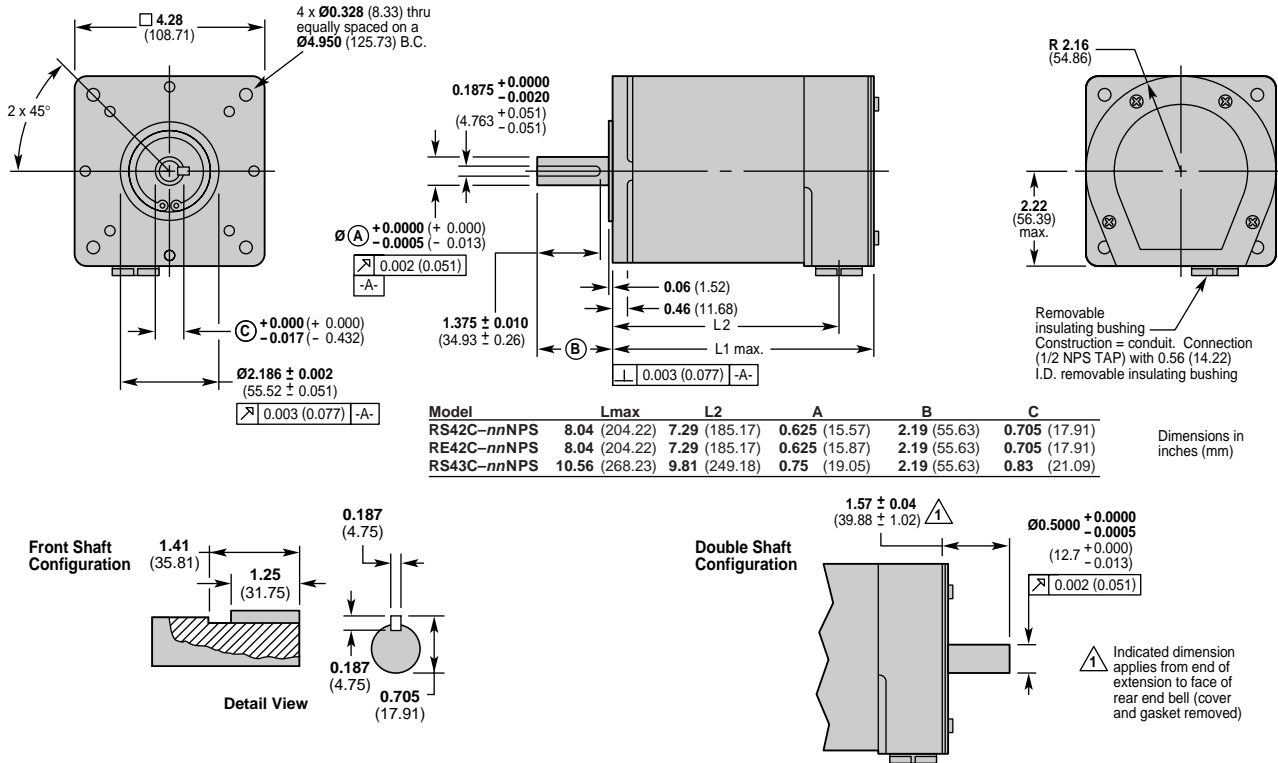

R Motors – Frame Size 42 Dimensions

2 – CHOOSE SERIES OR PARALLEL MOTOR WIRING

The R Motor’s windings—phase A and phase B—are *bifilar* windings made from double-stranded copper wire. Each phase has two half-windings, which can be wired together in series or parallel.

These two alternatives—series and parallel—produce different speed/torque characteristics, affect the motor’s current rating, and alter the motor’s operating temperature. They are explained below.

INTERLOCK TERMINALS

The interlock terminals on the motor connector comprise a safety feature that protects the motor connector. The drive checks for continuity between the interlock terminals. A jumper on the connector provides this continuity; the jumper must be in place, or the drive will not operate. If the connector is removed when the drive is running, continuity between the interlock terminals is broken. The drive considers this a fault: it illuminates the **MOTOR FAULT LED**, and turns off power to the motor.

Do not extend the interlock jumper wire beyond the connector. The interlock circuit is designed to work with a *very short* jumper. Longer wires may change the electrical characteristics of the circuit, making it more susceptible to noise. Therefore, do not use a long jumper.

GROUND THE MOTOR CASE

You must ground the motor case, for safety purposes. Connect a green/yellow wire from the motor's protective earth terminal to the drive's ground terminal on its motor connector. Inside the drive, this ground terminal connects directly to the ground pin on the AC power connector. (The C10 Cable Kit has a motor cable that contains a green/yellow wire.)

WIRING THE R MOTOR

The R Motor is sold with no cable attached. A cable kit is available from Compumotor (part number C10) that includes a motor cable and mounting hardware. To connect a motor cable, remove the end bell cover plate from the end of the motor, as shown below.

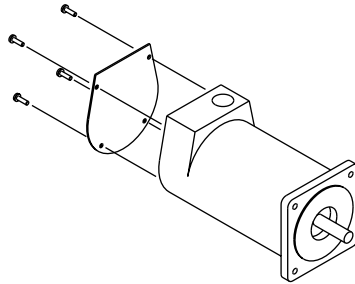

Removing Cover Plate

Make connections according to the following diagrams, which show typical series and parallel connections.

Cut individual wires to length, to avoid excess wire inside the end bell.

PRECAUTIONS

Follow these precautions when you wire the motor and connector.

1. Turn off power to the drive before connecting or disconnecting the motor connector.
2. Verify that no wire whiskers short out motor connections.
3. Do not apply power to the drive when the motor is not connected.
4. Never extend the interlock jumper beyond the motor connector.
5. Never connect anything other than the motor to the motor terminals.
6. When finished, perform the Automatic Test to verify proper connections.

SERIES WIRING

For series operation, make connections according to the next diagram.

Notice that you must use jumper wires to connect terminal #7 to #8, and to connect terminal #5 to #6. Use 18 AWG (0.75 mm) or larger diameter wire for the jumpers, with ring terminals attached to each end.

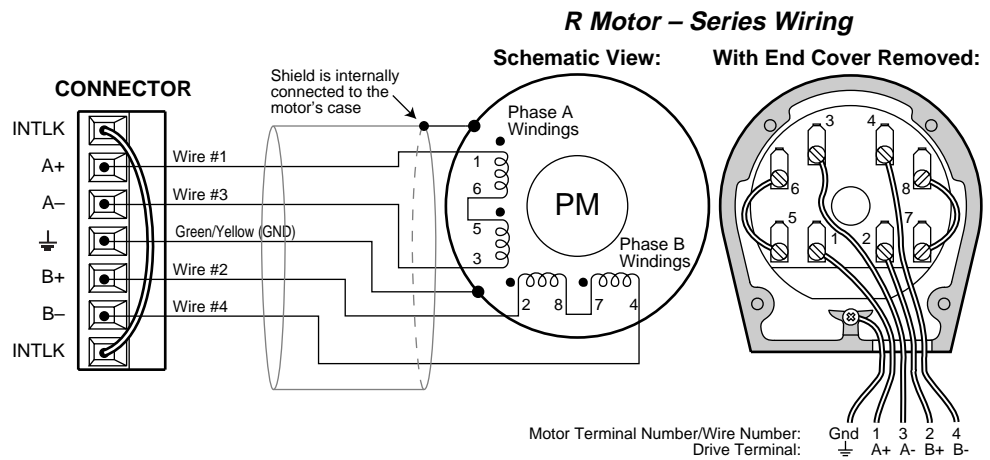

*Motor Connector – Wired for **SERIES** Motor Current*

The operating temperature of a motor connected in series will typically be lower than that of a motor connected in parallel. Therefore, you should operate your motor in series, if your application permits. Typically, series connections work well in high torque/low speed applications.

PARALLEL WIRING

For parallel operation, make connections according to the next diagram.

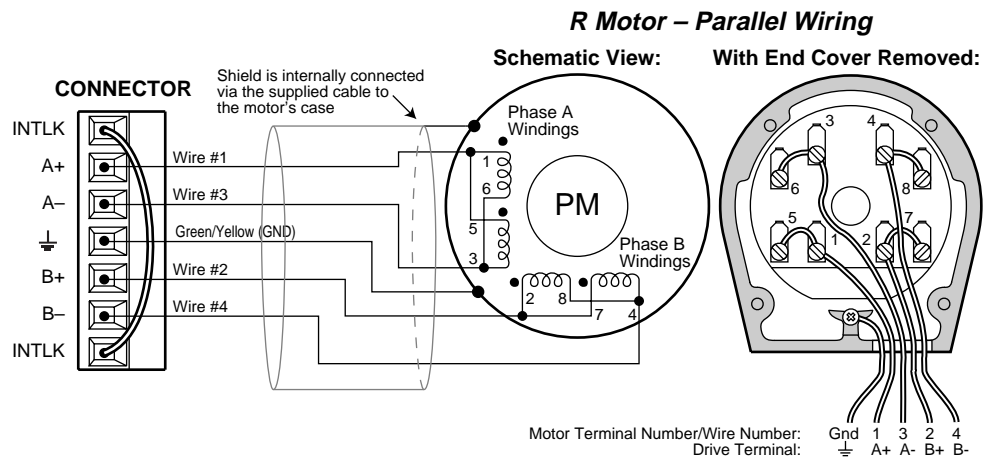

*Motor Connector – Wired for **PARALLEL** Motor Current*

Use jumper wires to connect terminal #2 to #7, #4 to #8, #1 to #5, and #3 to #6. Use 18 AWG (0.75 mm) or larger diameter wire, with ring terminals.

At higher speeds, a motor connected in parallel will produce more torque than the same motor connected in series. However, the operating temperature of the motor in parallel will be much higher.

If you operate your motor in parallel, you must measure motor temperature under actual operating conditions. R Motors have maximum allowable temperatures of 100°C (212°F).

CAUTION

High current in parallel connected motors may cause motor overheating. If the motor exceeds its maximum case temperature, reduce the duty cycle to 50%, or use automatic standby, or use forced air cooling to decrease motor temperature.

3 – QUICK TEST

Follow this procedure to have your ZETA4-240 Drive perform its *automatic test* function. Once you set DIP switches, connect the motor, and connect AC power, the automatic test will begin—the motor shaft will turn in the counterclockwise direction until you remove power. This will verify that the drive, motor, and motor cable work properly as a system.

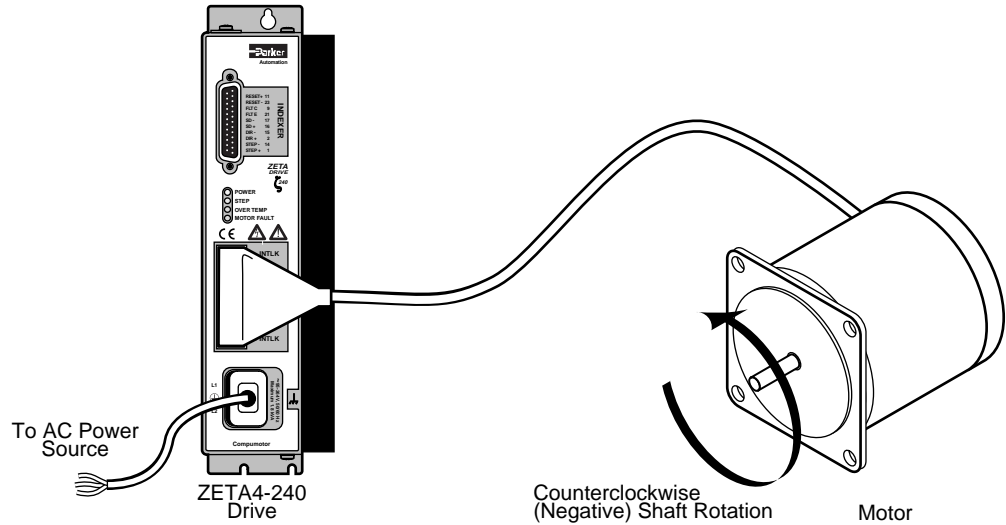

Quick Test Setup

This is a *bench top* procedure—as the drawing shows, you can perform it before you connect an indexer, mount the drive, or mount the motor. Full installation instructions follow this section.

1. SET DIP SWITCHES FOR SERIES MOTOR CURRENT

Two 12-position DIP switches are located on top of the ZETA4-240 Drive, behind a cover. Move the cover to access the switches. Before you change them, make note of the DIP switch settings. You will restore the switches to their original settings at the end of this procedure.

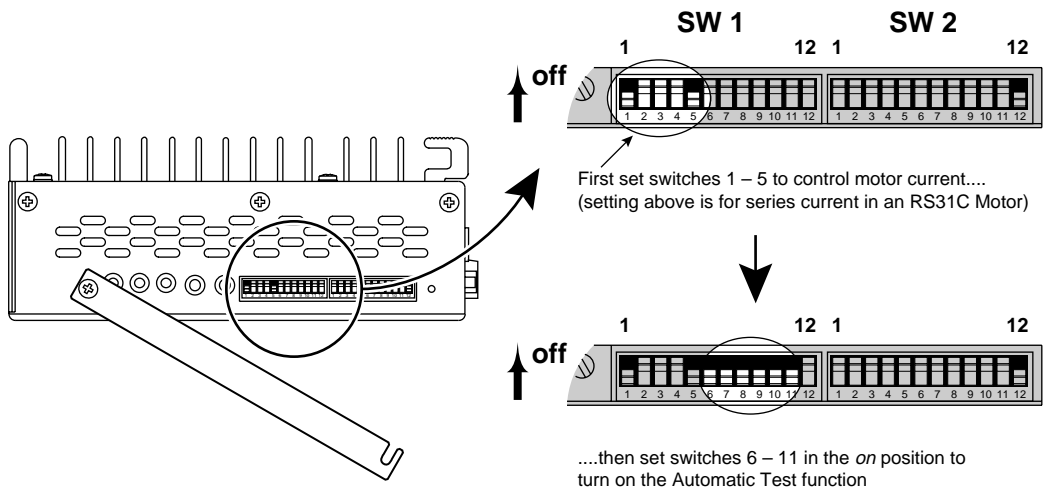

DIP Switch Location

Use the following table to set DIP switches SW1-#1 — SW1-#5 for *series* current for your R Motor.

Motor Size	Current	SW1-#1	SW1-#2	SW1-#3	SW1-#4	SW1-#5
RS31C	2.26A (pk)	on	off	off	off	on
RS32C	2.88A (pk)	on	off	on	on	off
RS33C	3.50A (pk)	on	on	off	on	on
RS42C	3.26A (pk)	on	on	off	off	on
RE42C	3.38A (pk)	on	on	off	on	off
RS43C	4.00A (pk)	on	on	on	on	on

Using a Non-Compumotor Motor?: see *Appendix A* at the end of this user guide

2. SET DIP SWITCHES FOR THE AUTOMATIC TEST FUNCTION

Set DIP switches SW1-#6 through SW1-#11 to the *on* position. This switch combination selects the automatic test function.

3. CONNECT THE MOTOR

Plug your R Motor cable's 7-pin connector into the drive's **MOTOR** connector. For safety, always observe the following two warnings:

WARNING

POWER MUST BE OFF when you connect or disconnect the motor connector. Lethal voltages are present on the screw terminals!

WARNING

You must ground the motor case. Large potentials can develop at the motor case that can create a lethal shock hazard if the motor case is not grounded.

The case of an R Motor will automatically be grounded when you plug the cable's 7-pin connector into the ZETA4-240 Drive.

4. CONNECT AC POWER

The ZETA4-240 Drive does not have an *on/off* switch. When you connect power, the automatic test will begin—the drive will turn on and the motor will start turning. Therefore, before you apply power to the ZETA4-240 Drive:

- Properly secure the motor.
- Do not attach a load to the motor shaft.

Wire your power cable to the 240VAC plug that you received with the drive. See the following diagram and instructions.

(For 120VAC information, consult *Appendix C, 120VAC Operations*).

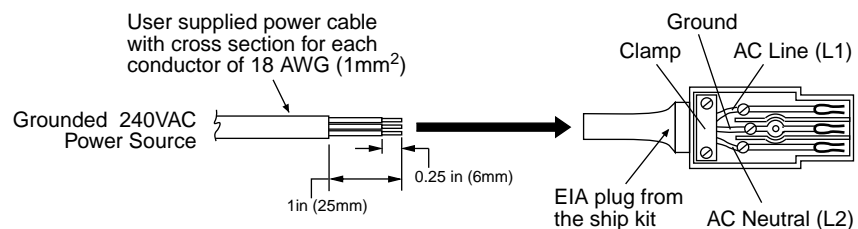

AC Input Connector Wiring

1. Remove the cover on the EIA plug.
2. Build your power cable as shown. **DO NOT USE A 120VAC CABLE.**
3. Slide the power cable into the plug.
4. Connect the conductor wires.
5. Lock the conductor wires under the clamp.
6. Reassemble the plug.

Plug the connector into the drive, and energize your grounded 240VAC power source.

5. OBSERVE THE AUTOMATIC TEST

Your ZETA4-240 Drive should now be running in automatic test mode:

- The motor shaft should rotate at approximately one revolution per second (1 rps) in the counterclockwise (negative) direction, until you remove power.
- LEDs on the front panel should operate as follows:

POWER	LED should illuminate
STEP	LED should alternately flash red and green
OVER TEMP	LED should not illuminate
MOTOR FAULT	LED should not illuminate

6. STOP THE AUTOMATIC TEST

Disconnect power to stop the motor. Set DIP switches 6 – 11 to *off*, or to their original settings. Return other DIP switches to their original settings.

INSTALLATION

The procedures in the rest of this chapter will lead you through the steps required to permanently install your ZETA4-240 Drive and motor.

1 – SET DIP SWITCHES

Configure the ZETA4-240 Drive's DIP switches for your motor and application. The drive's 24 DIP switches are located behind the movable metal cover on top of the drive. Switch 1 (SW1) and Switch 2 (SW2) are each 12-position DIP switches. The next table summarizes switch settings. At the end of this section, we show settings for individual ZETA motors. (If you use an O or R motor at 120VAC, see *Appendix C* for DIP switch settings.)

DEFAULT SETTINGS

The factory default position is *off* for all switches.

MOTOR CURRENT

Set DIP switches SW1-#1 — SW1-#5 for motor current. Verify that your motor wiring, connector wiring, and motor current rating match the series or parallel current that you set with these five switches.

DRIVE RESOLUTION

Set DIP switches SW1-#6 — SW1-#9 for drive resolution. There are sixteen settings, which range from 200 to 50,800 steps per revolution. The default setting is 25,000 steps per revolution.

Be sure to set your indexer to the same resolution as your ZETA4-240 Drive. If the indexer resolution and drive resolution do not match, commanded accelerations and velocities will not be properly scaled.

WAVEFORM

Set SW1-#10 and SW1-#11 to select a current waveform. There are four choices: one is a pure sine wave; the others reduce the current waveform's 3rd harmonic by 4%, 6%, or 10%. In most applications, the default setting (*both switches off* = -4% 3rd harmonic) provides the best performance. For further information about selecting a waveform, see the section *Match the*

Drive to the Motor later in this chapter.

NOTE: If you choose 200 steps/rev for resolution, do not select pure sine for a waveform. SW1-#6 — SW1-#11, when all *on*, do not select 200 steps/rev and pure sine—they select the automatic test (see below).

AUTOMATIC TEST

DIP switches SW1-#6 — SW1-#11 have a double function. As mentioned earlier in *Quick Test*, they select the Automatic Test function when they are all *on*. For any other setting, they select resolution and waveform.

STEP & DIRECTION/CW & CCW

SW1-#12 should be *off* if you use a step & direction indexer. All Compu-motor indexers are step and direction indexers.

If you use a clockwise/counterclockwise (CW & CCW) indexer, turn this switch *on*.

AUTOMATIC STANDBY

The *automatic standby* function allows the motor to cool when it is not moving. Automatic standby reduces motor current by 50% if the drive does not receive a step pulse for one second. Full current is restored upon the first step pulse that the drive receives. Be aware that reduced current results in reduced holding torque.

SW2-#1 should be *off* if you do not use automatic standby. Turn this switch *on* to use automatic standby. If you use position maintenance we recommend that you do not use automatic standby.

ANTI-RESONANCE DISABLE

SW2-#2 should be *off* for the anti-resonance circuit to be enabled. Normally, you will want anti-resonance enabled; therefore, this switch should be *off*. If you must disable anti-resonance, turn SW2-#2 *on*.

NOTE: If active damping is enabled via the rotary switch on top of the drive, anti-resonance is automatically disabled, regardless of the setting of SW2-#2. See *Damping in the ZETA4-240 Drive* later in this chapter for an explanation.

ANTI-RESONANCE PHASE

This switch allows a broad range of motors to benefit from the anti-resonance damping technique. SW2-#3 should be *off* if your mechanical system's resonant frequency is 200 Hz or less. SW2-#3 should be *on* if your mechanical system's resonant frequency is greater than 200 Hz, if your motor drives an extremely low inertia load, or if your system has an extremely high torque to inertia ratio.

ANTI-RESONANCE GAIN

Large rotor motors, or motors driving large inertial loads, may require a reduction in anti-resonance gain. This will be evident if the load becomes too responsive and settles in an overly abrupt manner for your application. SW2-#4 should be *off* if system's inertia is 20 kg-cm² or less. SW2-#4 should be *on* if system's inertia is greater than 20 kg-cm²

CURRENT LOOP GAIN

SW2-#5 should be *off* for normal current-loop gain. You can reduce the responsiveness of the current control loop by setting SW2-#5 to the *on* position. This may be necessary when connecting a motor with an extremely low inductance value, on the order of 2 mH. If you hear a high

ZETA4-240 DIP SWITCH SETTINGS

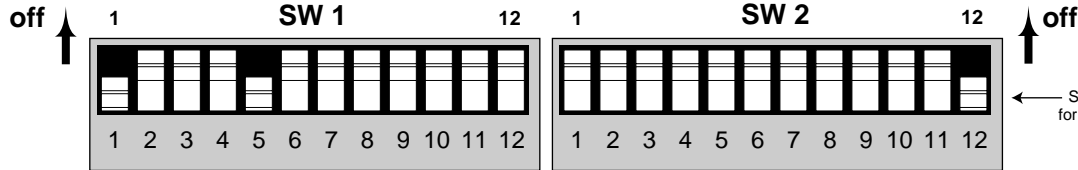

Current (amps pk)	1	2	3	4	5
0.14	off	off	off	off	off
0.26	off	off	off	off	on
0.39	off	off	off	on	off
0.51	off	off	off	on	on
0.64	off	off	on	off	off
0.76	off	off	on	off	on
0.89	off	off	on	on	off
1.01	off	off	on	on	on
1.14	off	on	off	off	off
1.26	off	on	off	off	on
1.38	off	on	off	on	off
1.51	off	on	off	on	on
1.63	off	on	on	off	off
1.76	off	on	on	off	on
1.88	off	on	on	on	off
2.01	on	on	on	on	on
2.14	on	off	off	off	off
2.26	on	off	off	off	on
2.38	on	off	off	on	off
2.51	on	off	off	on	on
2.63	on	off	on	off	off
2.76	on	off	on	off	on
2.88	on	off	on	on	off
3.01	on	off	on	on	on
3.13	on	on	off	off	off
3.26	on	on	off	off	on
3.38	on	on	off	on	off
3.50	on	on	off	on	on
3.63	on	on	on	off	off
3.75	on	on	on	off	on
3.88	on	on	on	on	off
RxxxC(P) ¹	4.00	on	on	on	on

Resolution ² (steps per revolution)	6	7	8	9
50,800 steps	off	off	off	on
50,000 steps	off	off	on	off
36,000 steps	off	off	on	on
25,600 steps	off	on	off	off
25,400 steps	off	on	off	on
Default Setting 25,000 steps	off	off	off	off
21,600 steps	off	on	on	off
20,000 steps	off	on	on	on
18,000 steps	on	off	off	off
12,800 steps	on	off	off	on
10,000 steps	on	off	on	off
5,000 steps	on	off	on	on
2,000 steps	on	on	off	off
1,000 steps	on	on	on	on
400 steps	on	on	on	off
200 steps	on	on	on	on

Waveform ² Default Setting	10	11
-4% 3rd harmonic	off	off
-10% 3rd harmonic	off	on
-6% 3rd harmonic	on	off
Pure sine	on	on

Automatic Test ²	6	7	8	9	10	11
	on	on	on	on	on	on

S&D/CW&CCW ²	12
Step & Direction Indexer	off
Clockwise & Counterclockwise Indexer	on

Static Torque ^{3,4}		Torque Range			
9	10	11	12		
off	off	off	off	0.26 – 0.72	36–100
off	off	off	on	0.73 – 1.41	101–200
off	off	on	off	1.42 – 2.33	201–330
off	off	on	on	2.34 – 3.47	331–492
off	on	off	off	1.48 – 2.12	210–300
off	on	off	on	2.13 – 3.60	301–510
off	on	on	off	3.61 – 7.06	511–1000
off	on	on	on	7.07 – 14.83	1001–2100
on	off	off	off	3.18 – 4.94	450–700
on	off	off	on	4.95 – 7.77	700–1100
on	off	on	off	7.78 – 16.24	1101–2300
on	off	on	on	16.25 – 35.31	2301–5000
on	on	off	off	5.65 – 8.12	800–1150
on	on	off	on	8.13 – 14.12	1151–2000
on	on	on	off	14.13 – 28.95	2001–4100
on	on	on	on	28.96 – 60.02	4101–8500

Inductance ^{3,4}		Inductance Range (mH)	
7	8	Motor:	
off	off	20.08 & greater	RS31C(S), RS32C(S), RS33C(S)
off	on	10.31 – 20.07	RS42C(S), 4S43C(S)
on	off	5.03 – 10.30	RS43C(P)
on	on	less than 5.02	RS31C(P), RS32C(P), RS33C(P), RE42C(P)

System Inertia		
6	off	Less than 20kg-cm ²
6	on	Greater than 20kg-cm ²

Current-Loop Gain		
5	off	Standard
5	on	Reduced

Anti-Resonance Gain		
4	off	Standard (system inertia < 20kg-cm ²)
4	on	Reduced (system inertia > 20kg-cm ²)

Anti-Resonance Phase		
3	off	Resonant Freq. < 200 Hz
3	on	Resonant Freq. > 200 Hz

Anti-Resonance Disable		
2	off	Anti-res. Enabled
2	on	Anti-res. Disabled

Automatic Standby		
1	off	Full Current
1	on	50% Current Standby

- NOTES:**
- RxxxC(P) can be RS31C(P), RS32C(P), RS33C(P), RS42C(P), RE42C(P), RS43C(P).
 - The drive reads these switches only upon power up. It reads all other switches continuously.
 - These switches are read only by active damping circuit; they are ignored if active damping is off.
 - Motor Part Number Suffix: (S) = Series Configuration (P) = Parallel Configuration

pitched (10 kHz) oscillation from the motor, you can decrease or eliminate the oscillation by reducing loop gain. Excessive loop gain may cause motor faults at high loads; reduce loop gain to eliminate this problem.

SYSTEM INERTIA

This switch selects the low or high inertia range, which pre-scales the 16-position rotary switch used by the active damping circuit. (This is explained later in this chapter, in 12 – *Configure Active Damping*.)

INDUCTANCE

The active damping circuit reads SW2-#7 and SW2-#8 to determine motor inductance. Set these switches according to your motor's *large-signal* inductance. The table shows the large-signal inductance range that corresponds to each of the four settings.

Large signal inductance is found by measuring the actual generator AC flux linkage and generator short circuit current under dynamic conditions. Small-signal inductance is the value read on an ordinary inductance bridge or meter. If you only have the small-signal inductance value available, use the formula below to approximate large-signal inductance:

$$\text{small signal inductance} * 1.5 \approx \text{large signal inductance}$$

NOTE: If active damping is *off*, switches SW2-#7 and SW2-#8 are ignored by the drive, and are inactive.

STATIC TORQUE

The active damping circuit reads SW2-#9 — SW2-#12 to determine the motor's static torque. Set these switches according to your motor; the table shows the range of static torque that corresponds to each of the four settings. NOTE: If active damping is *off*, switches SW2-#9 — SW2-#12 are ignored by the drive, and are inactive.

REPLACE COVER

Replace and secure the cover after you set the DIP switches.

DIP SWITCH SETTINGS FOR COMPUMOTOR R MOTORS

The next illustration summarizes switch settings for Compumotor R Motors.

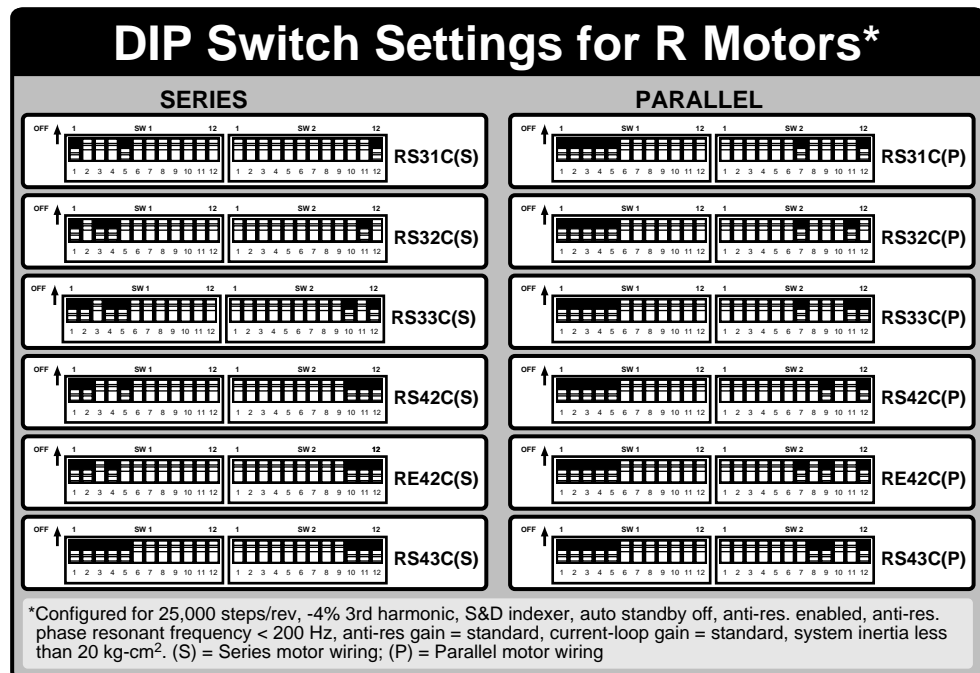

DIP Switch settings for Compumotor R Motors

2 – CONNECT AN INDEXER – INPUTS & OUTPUTS

Connect your indexer cable to the ZETA4-240 Drive's **INDEXER** connector, a 25 pin D-connector on the front of the drive. The cable that comes with Compumotor indexers is pre-wired for compatibility with the ZETA4-240 Drive—you can plug the cable directly into the ZETA4-240 Drive's indexer connector. (See *Appendix B, LVD and EMC Installation Guide* for additional instructions regarding EMC, and Compumotor's optional EMC compliant cable.)

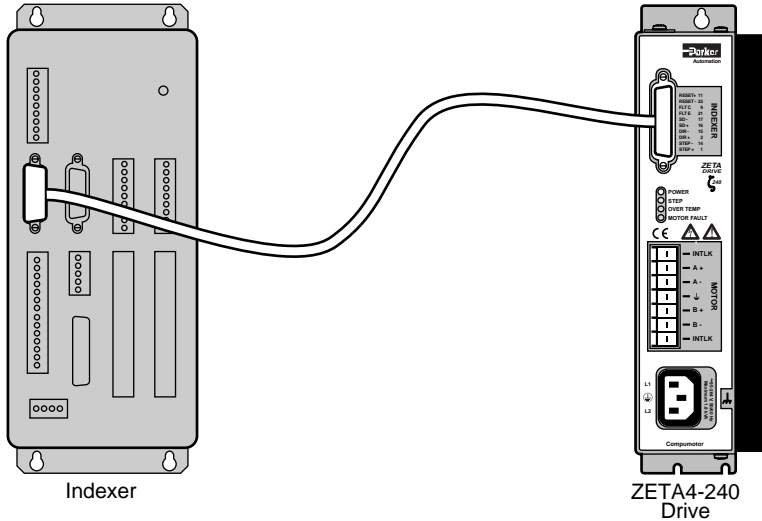

Connecting a Compumotor Indexer

If you make your own cable, or use a non-Compumotor indexer, consult the drawing below when you wire your cable and connector.

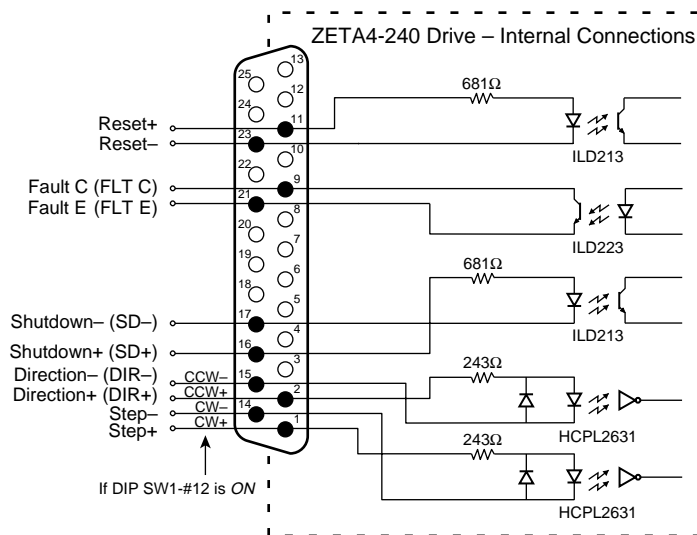

25 Pin D-Connector

Descriptions of each function on the 25 pin D-connector follow.

STEP INPUT

For every step pulse it receives on its step input, the drive will commutate the motor to increment rotor position. To send a step pulse to the drive, apply a positive voltage to **STEP+** with respect to **STEP-**. The drive registers the pulse on the rising edge.

The input is optically isolated. It may also be differentially driven.

Step input specifications are:

Input Current:	6.5 mA minimum	
	15 mA maximum	
Input Voltage:	3.5V minimum	(min. required for <i>on</i> or <i>high</i> signal)
	5.2V maximum*	
Step Pulse:	200 nanosecond minimum pulse width	
	200 nanosecond minimum off time	
	2 MHz maximum pulse rate	
Optically Isolated:	Yes	

*As a custom product, Compumotor can modify drive for higher input voltage

DIRECTION INPUT (DIR+ & DIR-)

While a positive voltage is applied to DIR+ with respect to DIR-, the drive will commutate the motor in the clockwise (positive) direction as it receives step pulses on its step input.

While zero voltage (or a negative voltage) is applied to DIR+ with respect to DIR-, the drive will commutate the motor in the counterclockwise (negative) direction as it receives step pulses.

The input is optically isolated. It may also be differentially driven.

Direction input specifications are:

Input Current:	6.5 mA minimum	
	15 mA maximum	
Input Voltage:	3.5V minimum	(min. required for <i>on</i> or <i>high</i> signal)
	5.2V maximum*	
Optically Isolated:	Yes	
Direction Change:	Direction input may change polarity coincident with first step pulse.	

*As a custom product, Compumotor can modify drive for higher input voltage

CLOCKWISE AND COUNTERCLOCKWISE (CW & CCW)

You can convert the ZETA4-240 Drive's step and direction inputs to clockwise and counterclockwise inputs, for use with a CW/CCW indexer. To do so, set DIP SW1-#12 to the *on* position. These changes result:

Pin #	SW1-#12 OFF	SW1-#12 ON	
1	Step+	Clockwise+	(CW+)
14	Step-	Clockwise-	(CW-)
2	Direction+	Counterclockwise+	(CCW+)
15	Direction-	Counterclockwise-	(CCW-)

Input specifications are the same as those listed above under *Step Input* and *Direction Input*. Each positive voltage pulse applied to CW+ with respect to CW- causes the drive to commutate the motor and increment rotor position in the *clockwise* direction. Each positive voltage pulse applied to CCW+ with respect to CCW- causes the drive to commutate the motor and increment rotor position in the *negative* direction.

SHUTDOWN INPUT (SD+ & SD-)

You can use the shutdown input to *shutdown*, or disable, the ZETA4-240 Drive. To activate shutdown, apply a positive voltage to SD+ with respect to SD- when the motor is not moving. During shutdown, the drive turns off current to the motor. The current stays off as long as the voltage is maintained on the shutdown input.

When you remove the voltage on the input, shutdown ends. The drive restores current to the motor, in the same phase relationship that existed before shutdown was invoked.

The shutdown input may also be differentially driven. Specifications are:

Input Current:	2.5 mA minimum 30 mA maximum	
Input Voltage:	3.5V minimum 13V maximum 5V maximum reverse voltage	(min. required for <i>on</i> or <i>high</i> signal)
Active Level:	While voltage is applied, current to motor is shut down. When voltage is removed, normal operations resume.	
Time:	250 nanosecond minimum width	
Optically Isolated:	Yes	

FAULT OUTPUT (FLT C & FLT E)

The ZETA4-240 can signal, through its fault output, that it has detected a fault. Internally, the terminals **FLT C** and **FLT E** connect to the open collector and open emitter, respectively, of an optically isolated transistor. The transistor acts like a switch: it conducts when the drive is functioning normally; it does not conduct when any of the following conditions exist.

- No power is applied to the drive
- AC line voltage is too low (less than 95VAC)
- Drive temperature is higher than 55°C (131°F)
- Drive detects a short circuit in motor or motor cable
- Motor is not connected
- Continuity between interlock terminals is broken
- Shutdown input is active

Fault output specifications are:

V _{CE} :	30VDC
V _{CE} SAT:	1 VDC
Collector Current:	80 mA minimum
Dissipation:	80 mW maximum
Optically Isolated:	Yes

RESET INPUT

The reset input provides a means for you to reset the ZETA4-240 Drive, without actually cycling power. To activate the reset input, apply a positive voltage to **RESET+** with respect to **RESET-** when the motor is not moving. The reset will not be complete until 0.7 seconds after the voltage is removed. A reset has the same effect on the drive as cycling power:

- DIP switch settings are loaded into the drive for configuration.
- Existing faults are cleared.
- Current to the motor is turned off while voltage is applied to the reset input.
- After voltage is removed from the reset input, the drive's soft start procedure will ramp current up to the start-up state. The motor will move to the nearest pole position.
- After voltage is removed from the reset input, there will be a 0.7 second delay before reset is complete, and normal operations can continue.

Reset input specifications are:

Input Current:	2.5 mA minimum 30 mA maximum	
Input Voltage:	3.5V minimum 13V maximum 5V maximum reverse voltage	(min. required for <i>on</i> or <i>high</i> signal)
Reset Voltage Pulse:	250 nanosecond minimum pulse width	
Active Level:	While voltage is applied, reset occurs. When voltage is removed, normal operations resume.	
Reset Delay:	0.7 second delay until reset is complete, after voltage is removed from input.	
Optically Isolated:	Yes	

3 – MATCH THE DRIVE TO THE MOTOR

Due to slight manufacturing variations, each motor has its own particular characteristics. In the procedure below, you will adjust three potentiometers, to match your ZETA4-240 Drive to your specific motor. You will also select the best current waveform to use with your motor.

The ZETA4-240 Drive's potentiometers are located behind the removable metal cover on top of the drive.

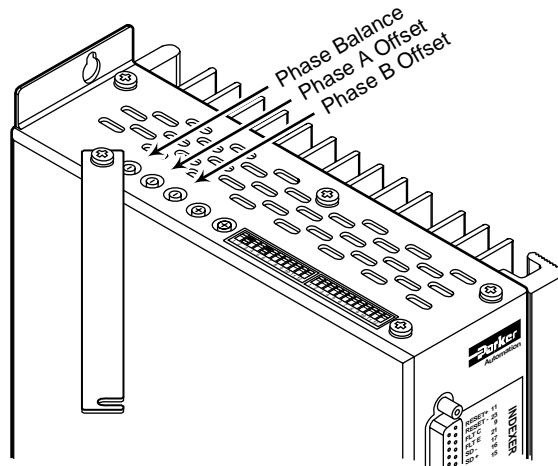

Potentiometer Locations

The single turn potentiometers control the following functions:

- Phase B Offset: Controls the DC offset of Phase B motor current
- Phase A Offset: Controls the DC offset of Phase A motor current
- Phase Balance: Adjusts the magnitude of Phase B with respect to Phase A

The procedure below is a *bench top* procedure—the drive, motor, and indexer should be temporarily connected together, but not yet permanently mounted. Apply AC power when necessary to perform the steps below.

Properly secure the motor. This procedure will be easier to perform if you do not attach the load to the motor shaft. The load is not required, because the characteristics you are matching are those only of the drive/motor combination.

MATCHING PROCEDURE

1. Apply power to the drive

Allow the drive to reach a stable operating temperature. This will take at least two minutes, and may take up to 30 minutes. For optimum results, perform the matching procedure at the same ambient temperature at which your application will operate.

2. Consult Table for Operating Speeds

For each of the adjustments that follow, consult the next table to find the speed at which to run the motor. These are speeds that cause *resonance* in the unloaded motor. When the motor is running at a resonant speed, you will notice increased noise and vibration. To make resonance the most noticeable, you may need to vary the speed around the value given below for

your motor. You can find the resonant speed by touching the motor lightly with your fingertips as you vary the speed. When you feel the strongest vibrations, the motor is running at resonant speed.

Motor	Offset Adjust (rps)	Balance Adjust (rps)	Waveform Adjust (rps)
RS31C (S)	2.93	1.47	0.73
RS31C (P)	2.78	1.39	0.70
RS32C (S)	3.08	1.54	0.77
RS32C (P)	2.76	1.38	0.69
RS33C (S)	3.07	1.53	0.77
RS33C (P)	2.49	1.24	0.62
RS42C (S)	1.78	0.89	0.45
RS42C (P)	1.55	0.77	0.39
RE42C (S)	2.99	1.50	0.75
RE42C (P)	2.04	1.02	0.51
RS43C (S)	1.80	0.90	0.45
RS43C (P)	1.40	0.70	0.35

(For O and R Motors at 120VAC, see *Appendix C, 120VAC Operation*.)

3. Run Motor at Offset Adjust Resonant Speed

Run your motor at the resonant speed listed in the *Offset Adjust* column. Vary the speed slightly until you find the resonance point.

4. Adjust Phase A Offset and Phase B Offset

Adjust the offset potentiometers for minimum motor vibration and smoothest operation. Alternate between Phase A and Phase B to find the minimum vibration point.

5. Run Motor at Balance Adjust Resonant Speed

Run your motor at the resonant speed listed in the *Balance Adjust* column. Vary the speed slightly until you find the resonance point.

6. Adjust Phase Balance

Adjust the Phase Balance potentiometer until you find the setting that provides minimum motor vibration and smoothest operation.

7. Repeat steps 3 - 6

8. Run Motor at Waveform Adjust Resonant Speed

Run the motor at the resonant speed listed in the *Waveform Adjust* column. Vary the speed slightly until you find the resonance point.

9. Choose Waveform for Smoothest Operation

Choose the current waveform that provides minimum motor vibrations and smoothest operation at the speed you selected in step 8. To find the best waveform, compare motor performance as you select different waveforms using DIP switches SW1-#10 and SW1-#11.

Waveform	SW1-#10	SW1-#11	
-4% 3rd harmonic	off	off	Default from factory
-10% 3rd harmonic	off	on	
-6% 3rd harmonic	on	off	
Pure sine	on	on	Do not use with 200 step/rev resolution

The drive reads these DIP switches only upon power up or reset. Therefore, you must cycle power or reset the drive each time you change the DIP switch settings.

10. Disconnect Power

Disconnect AC power to turn off the drive. Replace the cover over the potentiometers and DIP switches. This completes the matching procedure.

Proceed to the next section to mount the drive and motor.

4 – MOUNT THE DRIVE

Dimensions of the ZETA4-240 Drive are shown below.

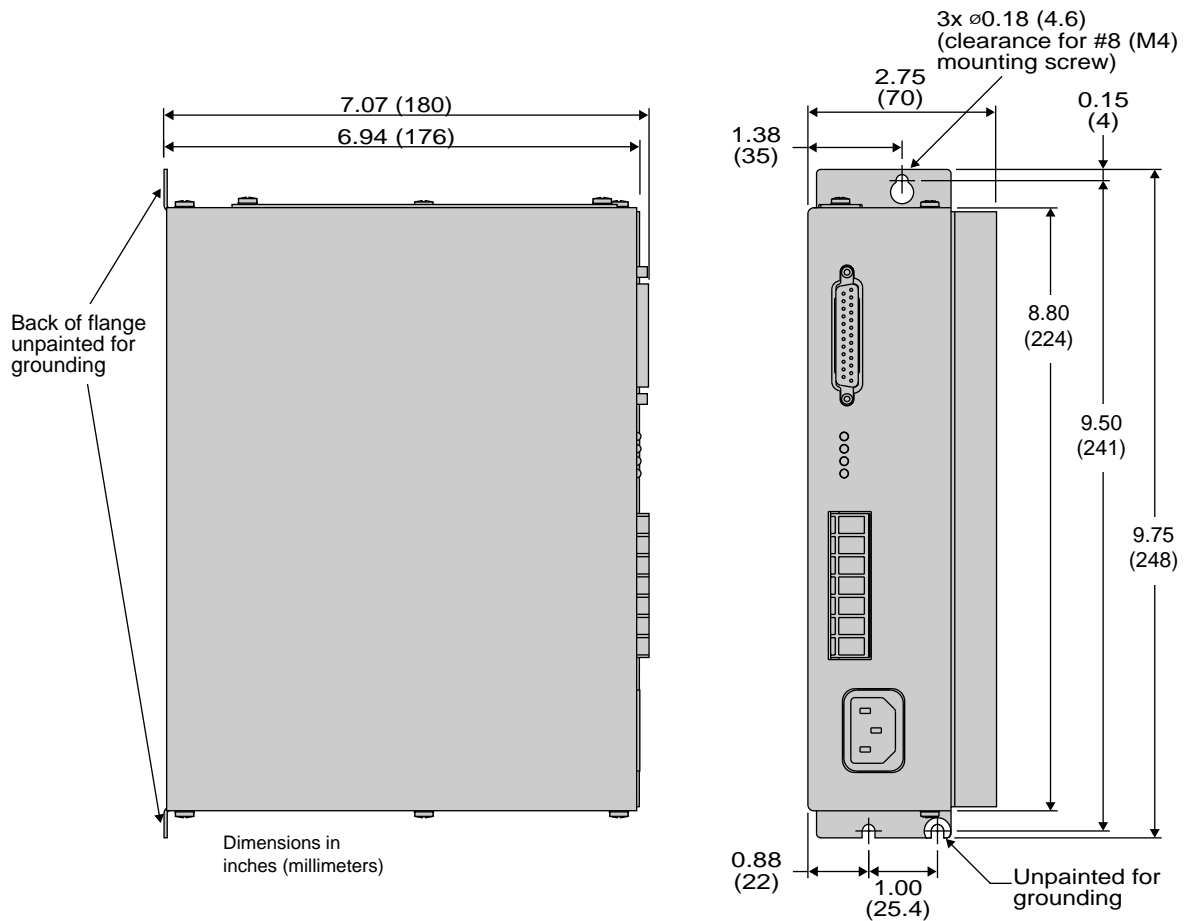

ZETA4-240 Drive Dimensions

ENVIRONMENTAL CONSIDERATIONS

TEMPERATURE SPECIFICATIONS

Maximum Ambient Temperature: 50°C (122°F)

Minimum Ambient Temperature: 0°C (32°F)

Overtemperature Shutdown Fault: 55°C (131°F)

The ZETA4-240 Drive has an internal temperature sensor, located near the heatsink. If the sensor reaches 55°C (131°F), it will trigger an overtemperature fault, and the drive will shut down.

FAN COOLING

Operating the ZETA4-240 Drive in high ambient temperatures may require fan cooling to keep the drive from shutting down due to an overtemperature fault.

HUMIDITY

Keep the relative humidity below 95%, non-condensing.

LIQUIDS

Do not allow liquids or fluids to come into contact with the ZETA4-240 Drive or its cables.

AIRBORNE CONTAMINANTS

Particulate contaminants, especially electrically conductive material such as metal shavings or grinding dust, can damage the ZETA4-240 Drive and motor. Do not allow contaminants to come into contact with the drive or motor.

PANEL LAYOUT

Follow these minimum spacing and clearance requirements when you mount multiple ZETA4-240 Drives.

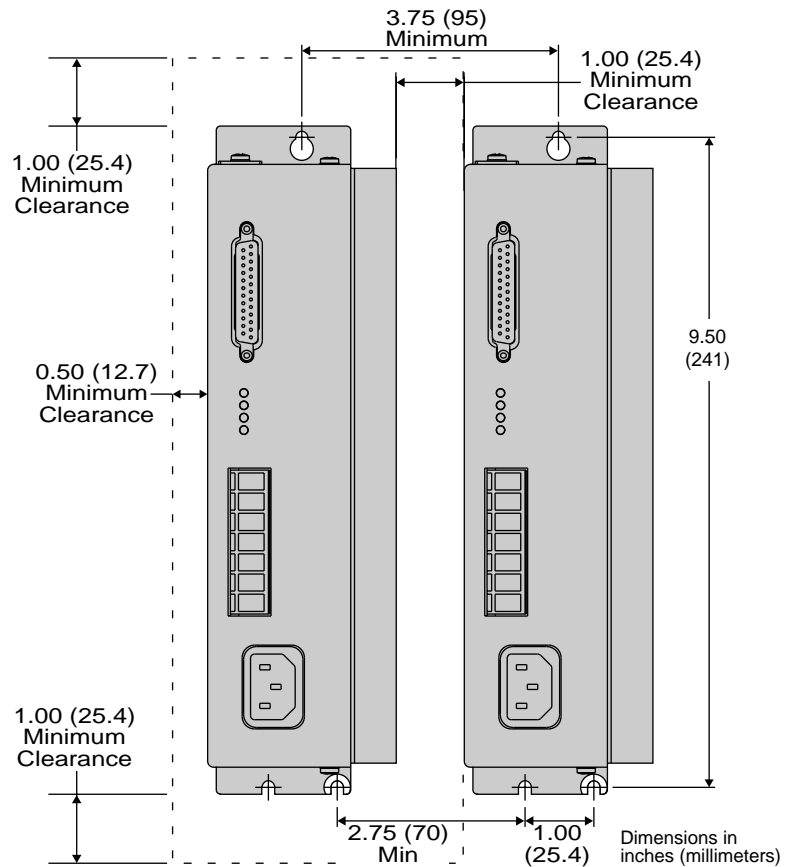

Panel Layout Dimensions

5 – MOUNT THE MOTOR

Use flange bolts to mount rotary step motors. The *pilot*, or centering flange on the motor's front face, should fit snugly in the pilot hole.

Do not use a foot-mount or cradle configuration, because the motor's torque is not evenly distributed around the motor case. When a foot mount is used, for example, any radial load on the motor shaft is multiplied by a much longer lever arm.

Motors used with the ZETA4-240 Drive can produce very high torque and acceleration. If the mounting is inadequate, this combination of high torque/high acceleration can shear shafts and mounting hardware. Because of shock and vibration that high accelerations can produce, you may need heavier hardware than for static loads of the same magnitude.

Under certain move profiles, the motor can produce low-frequency vibrations in the mounting structure that can cause fatigue in structural members. A mechanical engineer should check the machine design to ensure that the mounting structure is adequate.

WARNING

Improper motor mounting can jeopardize safety of personnel, and compromise system performance.

For Compumotor R Series motor dimensions, see *Select a Motor* earlier in this chapter.

MOTOR TEMPERATURE & COOLING

The motor's face flange is used not only for mounting; it is also a *heatsink*. Mount the face flange to a large thermal mass, such as a thick steel or aluminum plate, which should be unpainted, clean, and flat. Heat will be conducted from inside the motor, through the face flange, and dissipated in the thermal mass. This is the best way to cool the motor. You can also use a fan to blow air across the motor for increased cooling, if conduction through the flange does not provide enough cooling.

MOTOR MODIFICATIONS

Modifying or machining the motor shaft will void the motor warranty. Contact a Compumotor Applications Engineer (800-358-9070) about shaft modifications as a custom product.

EXTENDING MOTOR CABLES

If you need to extend R Motor cables beyond the standard 10 feet (3 m), consult the table below for recommended wire sizes. Cables longer than 50 feet (15 m) may degrade system performance. Do not extend cables beyond 200 feet (61 m). LVD and EMC installations require special cables, which are not included in the table below; see *Appendix B, LVD and EMC Installation Guide* for additional instructions for LVD/EMC cables.

Motor Type	Max. Current (amps)	Less than 100 ft. (30 m)		100 – 200 ft. (30 – 60 m)	
		Size: AWG	mm ²	AWG	mm ²
RS31C (S)	2.26	20	0.50	18	0.75
RS31C (P)	4.00	18	0.75	16	1.50
RS32C (S)	2.88	20	0.50	18	0.75
RS32C (P)	4.00	18	0.75	16	1.50
RS33C (S)	3.50	18	0.75	16	1.50
RS33C (P)	4.00	18	0.75	16	1.50
RS42C (S)	3.26	20	0.50	18	0.75
RS42C (P)	4.00	18	0.75	16	1.50
RE42C (S)	3.38	20	0.50	18	0.75
RE42C (P)	4.00	18	0.75	16	1.50
RS43C (S)	4.00	18	0.75	16	1.50
RS43C (P)	4.00	18	0.75	16	1.50

(S) = Series Configuration (P) = Parallel Configuration Rated current in wire sizes shown may result in a maximum temperature rise of 10°C (18°F) above ambient.

6 – CONNECT THE MOTOR TO THE LOAD – COUPLERS

Align the motor shaft and load as accurately as possible. In most applications, some misalignment is unavoidable, due to tolerance buildups in components. However, excessive misalignment may degrade your system's performance. Three misalignment conditions, which can exist in any combination, are illustrated and described below.

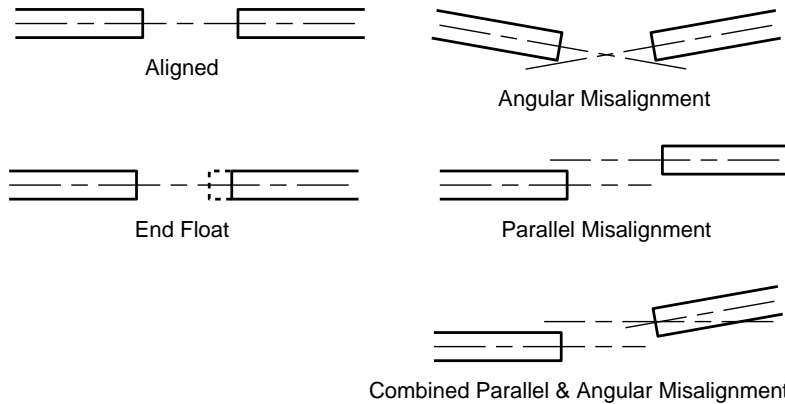

Misalignment Conditions

- **Angular Misalignment:** The center lines of two shafts intersect at an angle other than zero degrees.
- **Parallel Misalignment:** The offset of two mating shaft center lines, although the center lines remain parallel to each other.
- **End Float:** A change in the relative distance between the ends of two shafts.

The type of misalignment in your system will affect your choice of coupler.

SINGLE-FLEX COUPLING

Use a single-flex coupling when you have angular misalignment only. Because a single-flex coupling is like a hinge, one and only one of the shafts must be free to move in the radial direction without constraint. *Do not use a double-flex coupling in this situation:* it will allow too much freedom and the shaft will rotate eccentrically, which will cause large vibrations and catastrophic failure. *Do not use a single-flex coupling with a parallel misalignment:* this will bend the shafts, causing excessive bearing loads and premature failure.

DOUBLE-FLEX COUPLING

Use a double-flex coupling whenever two shafts are joined with parallel misalignment, or a combination of angular and parallel misalignment (the most common situation).

Single-flex and double-flex couplings may or may not accept end play, depending on their design.

RIGID COUPLING

Rigid couplings are generally not recommended, because they cannot compensate for *any* misalignment. They should be used only if the motor or load is on some form of floating mounts that allow for alignment compensation. Rigid couplings can also be used when the load is supported entirely by the motor's bearings. A small mirror connected to a motor shaft is an example of such an application.

COUPLING MANUFACTURERS

HUCO 70 Mitchell Blvd, Suite 201 San Rafael, CA 94903 (415) 492-0278	ROCOM CORP. 5957 Engineer Drive Huntington Beach, CA 92649 (714) 891-9922	HELI-CAL P.O. Box 1460 Santa Maria, CA 93456 (805) 928-3851
---	--	--

7 – CONNECT AC POWER

At this point in your installation procedure, you should have mounted your drive and motor, coupled the motor to the load, and connected the indexer and motor cables to the drive.

The ZETA4-240 Drive does not have an *on/off* switch. When you plug the power cord into the drive, the system will turn on. Therefore, before you apply power to the ZETA4-240 Drive, verify the following:

- Motor should be properly secured
- Motor cable should be connected to drive
- Drive should be properly mounted
- Indexer cable should be connected to drive
- Indexer cable should not be in close physical proximity to motor cable
- Active Damping rotary switch should be set to zero
- Electronic Viscosity rotary switch should be set to zero.

APPLY POWER

The ZETA4-240 Drive is shipped with a mating connector for its AC power input. Wire your power cable to this mating connector. (Wiring instructions and a diagram were given earlier in this chapter, under *Connect AC Power* in the *Quick Test* section.) To apply power, plug the connector into the drive's AC power input. Your AC power source should meet the following specifications:

Specifications – AC Power Input

Input Power:	240VAC nominal 95VAC minimum 264VAC maximum 50 – 60 Hz
Inrush Current:	25 amps maximum
Fuses:	No user serviceable fuses
Grounding:	You must provide a proper AC power ground
Transformer:	To size stepdown transformer, use Volt-Amp rating (see below)

WARNING

The motor case and drive are grounded through the AC power connector ground pin. You must provide a proper AC power ground for safety purposes.

PEAK POWER RATINGS

The amount of power the ZETA4-240 Drive requires from your AC power source depends upon the motor you use, whether it is wired in series or parallel, and upon your specific application. The next table shows *peak* power requirements at 240VAC. Power required for your application may be less. (For 120VAC information, see *Appendix C, 120VAC Operations*.)

Motor Type	Current (Amps)	Cabinet Loss (W)	Peak Motor Loss (W)	Peak Shaft Power (W)	Peak Total Power (W)	Volt-Amp Rating (VA)
RS31C (S)	2.26	46.0	131	204	381	611
RS31C (P)	4.00	62.1	417	393	872	1337
RS32C (S)	2.88	29.3	157	230	416	649
RS32C (P)	4.00	87.7	331	455	873	1312
RS33C (S)	3.50	34.2	162	336	532	822
RS33C (P)	4.00	76.3	342	528	947	1401
RS42C (S)	3.26	39.2	94	327	461	758
RS42C (P)	4.00	61.8	215	537	814	1258
RE42C (S)	3.38	38.4	89	461	588	962
RE42C (P)	4.00	55.1	229	629	913	1384
RS43C (S)	4.00	51.9	159	487	697	1016
RS43C (P)	4.00	73.7	325	630	1028	1526

(S) = Series Configuration (P) = Parallel Configuration

8 – TEST THE INSTALLATION

System installation should be complete at this point. Perform the test procedure below to verify that your system is functioning properly. (Procedures to configure the drive's damping features follow this test.)

In the test procedure, you will command single revolution moves in the clockwise and counterclockwise direction. If your mechanics do not permit such moves, choose a move that allows you to easily verify correct system response.

TEST PROCEDURE

1. Apply power

The green LED labeled **POWER** should illuminate.

2. Command a slow move of one revolution in the clockwise direction

Verify that the motor turns as commanded. The bicolor LED labeled **STEP** should be illuminated green while the move is in progress.

3. Command a slow move of one rev in the counterclockwise direction

Verify that the motor turns as commanded. The bicolor LED labeled **STEP** should be illuminated green while the move is in progress.

4. Test the shutdown input

With the motor stopped, activate the shutdown input. The motor will have no torque when shutdown is activated. You should be able to turn the motor manually (if your mechanics permit).

Successful completion of this procedure will verify that your indexer and motor are correctly connected to the ZETA4-240 Drive, and that the drive is functioning properly. Proceed to the following sections to configure the ZETA4-240 Drive's damping features.

If the test was unsuccessful, observe the LEDs on the front panel of the ZETA4-240 Drive while you try the test procedure—they may indicate the cause of the problem. (*Chapter 3, Troubleshooting* has a complete description of LED functions.) Review earlier sections of this user guide, verify that you have completed each step, and try the test procedure again.

If the test is still unsuccessful, proceed to *Chapter 3, Troubleshooting* for problem identification and solution procedures.

9 – RESONANCE, RINGING AND DAMPING – DISCUSSION AND THEORY

In this section we will discuss resonance and ringing in step motors. This information will help you configure the ZETA4-240 Drive's damping features—anti-resonance, active damping, and electronic viscosity.

All step motors have natural resonant frequencies, due to the nature of their mechanical construction. Internally, the rotor acts very similarly to a mass suspended on a spring—it can oscillate about its commanded position. Externally, the machine, mounting structure, and drive electronics can also be resonant, and interact with the motor. During a move, two types of problems can arise from these causes: resonance and ringing transients.

RESONANCE (STEADY STATE RESPONSE)

Resonance is a *steady state* phenomenon—it occurs when the motor’s natural resonant frequencies are excited at particular velocities. It is not caused by transient commands that we give the motor. If you slowly increase your motor’s speed from zero to 20 rps, for example, you may notice “rough” spots at certain speeds. The roughness is resonance; it is depicted in the next drawing.

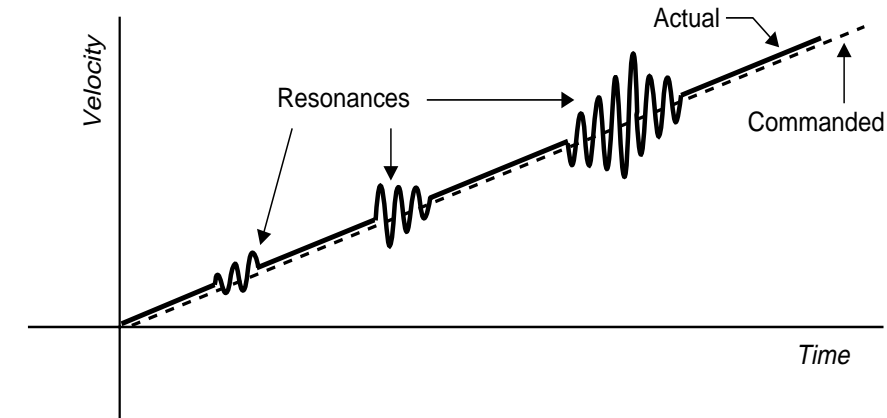

Instead of moving at the commanded velocity, the motor is oscillating between speeds faster and slower than commanded. This causes *error in rotor position*.

Resonance points can differ in intensity. The drawing shows a typical case—as motor speed increases, resonances of varying levels occur. Usually, the motor can accelerate through the resonance point, and run smoothly at a higher speed. However, if the resonance is extreme, the rotor can be so far out of position that it causes the motor to stall.

Resonance is affected by the load. Some loads are resonant, and can make motor resonance worse. Other loads can damp motor resonance. To solve resonance problems, system designers will sometimes attach a damping load, such as an inertial damper, to the back of the motor. However, such a load has the unwanted effect of decreasing overall performance, and increasing system cost.

The ZETA4-240 Drive has internal electronics that can damp resonance, and *increase* system performance. No external devices are necessary.

RINGING (TRANSIENT RESPONSE)

Inside a step motor, the rotor behaves like a mass on a spring, as mentioned above. When commanded to quickly accelerate to a given velocity, the rotor will “ring” about that velocity, oscillating back and forth. As shown in the next drawing, the ringing *decays*—grows smaller over time—and the rotor eventually settles at the commanded velocity.

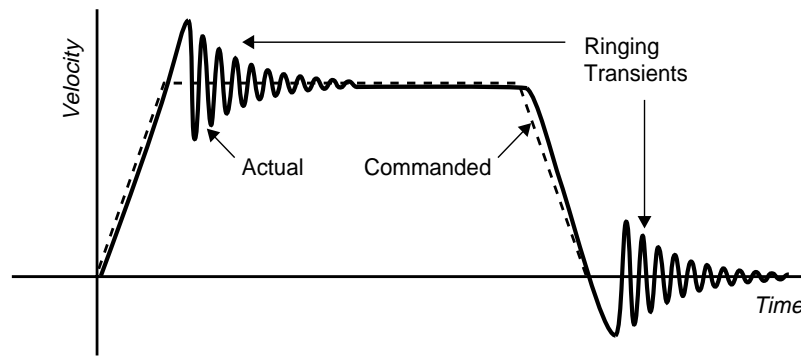

Ringing Transients

Notice that ringing can be caused both by accelerating (or decelerating) to a commanded velocity, and decelerating to a stop. In all of these cases, ringing causes *error in rotor position*.

Ringing is a *transient* phenomenon (unlike resonance, which occurs during steady state operations). It is a response to a sudden change that we impose on the system, such as “Accelerate to Velocity” or “Stop.”

Several problems are associated with ringing. It can cause audible noise; the motor must have a margin of extra torque to overcome the ringing; and longer settling times can decrease throughput.

To eliminate these problems, system designers use damping to force the ringing to decay quickly. Inertial dampers have been used as components in passive damping methods. Accelerometers, encoders, and tachometers have been used as components in active damping methods. These devices can have the unwanted effect of limiting performance, adding complexity, and increasing cost.

The ZETA4-240 Drive has internal electronics that damp ringing transients, causing them to decay quickly. No external devices are necessary.

10 – DAMPING IN THE ZETA4-240 DRIVE

The ZETA4-240 Drive has three different circuits that can damp resonance and ringing.

Anti-Resonance – General-purpose damping circuit. The drive ships from the factory with anti-resonance enabled. You can optimize its performance by setting two DIP switches. Anti-resonance provides aggressive and effective damping.

Active Damping – Extremely powerful damping circuit. The drive ships from the factory with active damping disabled. You must set seven DIP switches (SW2-#6 – SW2-#12) and a rotary switch to enable active damping, and optimize it for a specific motor size and load.

Electronic Viscosity – Provides damping at lower speeds. The drive ships with electronic viscosity disabled. You must set a rotary switch to enable electronic viscosity, and optimize it for the specific application.

The first two damping circuits—anti-resonance and active damping—work at speeds greater than three revolutions per second (rps). Electronic viscosity works at speeds from rest up to three rps. The drive will automatically switch between the damping circuits, based upon the motor’s speed. The next drawing shows the effective range of each circuit.

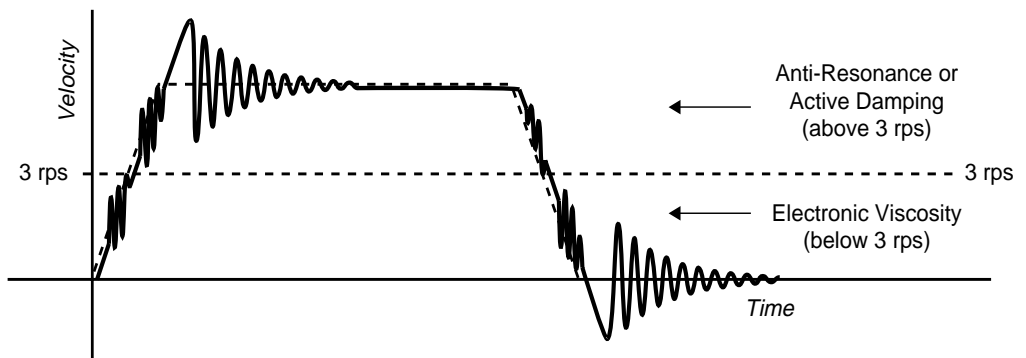

Resonances, Ringing Transients, and Effective Range of Damping Circuits

Above 3 rps, the drive automatically enables anti-resonance or active damping—but not both at the same time. They are mutually exclusive.

If the rotary switch for active damping is set to the zero position, the drive enables anti-resonance. If the rotary switch is set to any position other than zero, the drive enables active damping. This relationship is shown in the next drawing. Notice that anti-resonance can also be disabled with a DIP switch.

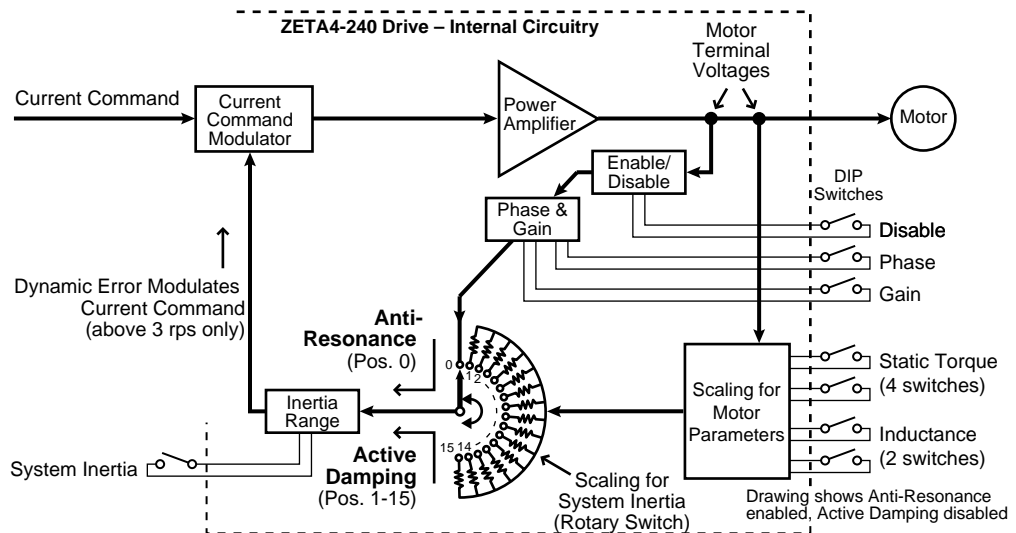

Anti-Resonance and Active Damping – Block Diagram

Differences between anti-resonance and active damping are described next; refer to the block diagram above.

ANTI-RESONANCE

Anti-resonance monitors the drive's motor terminals, and looks at power exchange between the drive and motor. From this, it extracts information about error in rotor position caused by resonance or ringing. It modifies the internal motor current command to correct for the error.

Anti-resonance is a general-purpose circuit. It corrects rotor position error, without knowledge about the system—whether the motor is large or small, or the system inertia is high or low. You can optimize the circuit by setting two DIP switches. One selects a range for the circuit's phase; the other selects a range for the circuit's gain.

ACTIVE DAMPING

Active damping monitors the motor terminals and, like anti-resonance, uses the same current command modulator to modify motor current.

Active damping uses a different method to extract information about rotor position error, however. The circuit's gains are adjustable—you can configure it for your particular system. DIP switches scale the circuit for motor inductance, static torque and inertia range. A 16-position rotary switch scales the circuit for system inertia.

The active damping circuit uses this information for two purposes:

1. It determines error in rotor position *very* accurately.
2. It adjusts the gains of its feedback loop, based upon how much inertia the system has, and how much torque the motor can produce.

If the rotor rings or vibrates, the active damping circuit will detect the corresponding error in rotor position. It will then modify the motor current command to damp the ringing.

DIP switches on top of the drive set the amount of motor current during normal operations; this current is constant. To damp ringing, the active damping circuit can cause the drive to produce up to twice as much current as is set by the DIP switches. The extra current is only applied while the circuit damps oscillations, and lasts a very brief time.

ELECTRONIC VISCOSITY (EV)

The ZETA4-240 Drive uses closed loop current control to develop and maintain precise currents in the motor phases. When EV is off, the current loops have a bandwidth of approximately 1000 Hz. Because this bandwidth is well beyond the knee of step motor speed-torque curves, the current loop dynamics do not limit the response of the motor.

EV monitors motor velocity, and turns on below 3 rps. It “detunes” the current loop compensation values and brings the bandwidth down to 150 Hz. With this lower bandwidth, the drive electronics become “sluggish.” Ordinarily, when the rotor oscillates, it generates current in the motor's coils; but with EV's lower bandwidth, the drive's electronics impede the flow of current caused by oscillations.

The effect on the motor is as if there were a viscous drag on the rotor. At the end of a move, oscillations are damped, and the rotor quickly comes to rest. After accelerating or decelerating to velocities below 3 rps, the rotor quickly settles at the commanded velocity. EV significantly reduces low speed velocity ripple during moves below 3 rps.

EV is a “passive” circuit. It imposes viscosity on the system, but has no feedback loop to monitor the effect of the viscosity. EV keeps the amount of viscosity the same, regardless of the response of the system.

You can adjust the amount of viscosity by setting the rotary switch. This allows you to tailor the circuit for different motor sizes and system inertias, and adapt it to your application.

WHAT'S NEXT?

We recommend that you complete the next sections, and configure active damping and electronic viscosity. Even if you believe resonance and ringing will not cause problems in your system, you may find that the ZETA4-240 Drive's damping circuits provide increased smoothness, reduced audible noise, and better performance.

If you choose not to use active damping and electronic viscosity, at least

use anti-resonance. Verify that anti-resonance is enabled (DIP SW2-#2 off), and that the rotary switches on the front of the drive, for active damping and electronic viscosity, are set to zero.

11 – SET ROTARY SWITCHES TO ZERO

The ZETA4-240 Drive has two rotary switches located behind the movable cover plate on top of the drive:

10-Position Switch: for Electronic Viscosity (positions 0 – 7 are active)

16-Position Switch: for Active Damping

Set each switch to zero. A setting of zero disables electronic viscosity and active damping. In the steps below, you will determine new switch settings to activate these two functions.

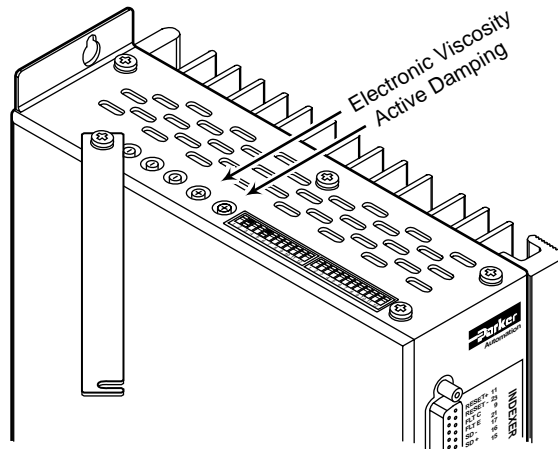

Rotary Switch Location

12 – CONFIGURE ACTIVE DAMPING

Follow these steps to configure the active damping circuit.

1. Verify Correct Drive/Motor Matching

See *Match the Drive to the Motor* earlier in this chapter. To be fully effective, the active damping circuit requires proper matching. If you are replacing a component (new drive or motor in an existing application), you must re-match your system.

2. Verify Correct DIP Switch Settings

Anti-Resonance	SW2-#2	switch in <i>OFF</i> position
Inductance	SW2-#7 – #8	set for your motor
Static Torque	SW2-#9 – #12	set for your motor

3. Verify that the Active Damping Rotary Switch is at Zero

4. Calculate the Maximum Rotary Switch Setting

To do this, first calculate your system inertia. Be sure to include the motor's rotor inertia. Then consult the table of inertia ranges below. Find the switch setting that corresponds to your system inertia.

DIP SW2-#6 in OFF Position (Low Inertia Range)

Switch Position	Total Inertia (kg-cm ²)	Total Inertia (kg-m ² x 10 ⁻⁶)	Total Inertia (oz-in ²)
15	0.088 - 0.205	8.8 - 20.5	0.481 - 1.121
14	0.205 - 0.572	20.5 - 57.2	1.121 - 3.127
13	0.572 - 1.069	57.2 - 106.9	3.127 - 5.845
12	1.069 - 1.754	106.9 - 175.4	5.845 - 9.590
11	1.754 - 2.727	175.4 - 272.7	9.590 - 14.910
10	2.727 - 3.715	272.7 - 371.5	14.910 - 20.312
9	3.715 - 5.020	371.5 - 502.0	20.312 - 27.447
8	5.020 - 6.275	502.0 - 627.5	27.447 - 34.308
7	6.275 - 8.045	627.5 - 804.5	34.308 - 43.986
6	8.045 - 9.595	804.5 - 959.5	43.986 - 52.460
5	9.595 - 11.760	959.5 - 1176.0	52.460 - 64.297
4	11.760 - 14.245	1176.0 - 1424.5	64.297 - 77.884
3	14.245 - 15.895	1424.5 - 1589.5	77.884 - 86.905
2	15.895 - 17.765	1589.5 - 1776.5	86.905 - 97.130
1	17.765 - 20.570	1776.5 - 2057.0	97.130 - 112.466
0	Active Damping Disabled		

DIP SW2-#6 in ON Position (High Inertia Range)

Switch Position	Total Inertia (kg-cm ²)	Total Inertia (kg-m ² x 10 ⁻⁶)	Total Inertia (oz-in ²)
15	13 - 31	1324 - 3084	75 - 169
14	31 - 86	3084 - 8606	169 - 471
13	86 - 161	8606 - 16084	471 - 879
12	161 - 264	16084 - 26390	879 - 1443
11	264 - 410	26390 - 41029	1443 - 2243
10	410 - 559	41029 - 55894	2243 - 3056
9	559 - 755	55894 - 75528	3056 - 4129
8	755 - 944	75528 - 94411	4129 - 5162
7	944 - 1210	94411 - 121041	5162 - 6618
6	1210 - 1444	121041 - 144362	6618 - 7893
5	1444 - 1769	144362 - 176935	7893 - 9674
4	1769 - 2143	176935 - 214323	9674 - 11718
3	2143 - 2391	214323 - 239148	11718 - 13075
2	2391 - 2673	239148 - 267283	13075 - 14614
1	2673 - 3095	267283 - 309486	14614 - 16921
0	Active Damping Disabled		

Active Damping Rotary Switch Settings & Corresponding Inertia Ranges

This is your *maximum* switch setting. If you are on the boundary between two switch settings, pick the lower of the two numbers. In the rest of this procedure, **never set the switch higher than this maximum setting.**

5. Make a Move With Active Damping Turned Off

(Rotary switch should be in the zero position.) This is your baseline move. Notice the sound, amount of motor vibration, etc. This move shows how your system operates with anti-resonance enabled, and active damping disabled. Each time you adjust this switch, you will compare results with this baseline move.

The move should be representative of your application, with similar velocity and acceleration. The speed must be faster than 3 rps, in order for the drive to activate anti-resonance or active damping.

6. Turn On Active Damping

Turn the active damping rotary switch to position 1. This turns on active damping at its lowest setting, and disables anti-resonance.

You can change the rotary switch setting “on the fly.” You do not have to cycle power each time you change the switch setting. During a repetitive move, you can change the switch setting while the move is in progress. This allows you to immediately compare two different switch settings.

7. Make a Move With Active Damping Turned On

Compare the sound and vibration to the baseline move.

8. Increase the Switch Setting

Turn the rotary switch to position 2 (unless position 1 is your calculated maximum). Make the move again. Compare the sound and vibration to the levels obtained at the lower setting.

9. Find the Ideal Switch Setting

Continue to increase the switch setting by single increments. Each time you increase the setting, compare the results with the lower setting. Increase the setting until you obtain optimum results for your move. This will be the setting that yields the lowest audible noise and smoothest motor operation.

Never exceed your maximum switch setting. For many applications, you will not need to go as high as the maximum setting. If you do not see perceptible improvement from one switch setting to the next, use the lower switch setting.

Higher switch settings result in higher dynamic motor current during transients, which can cause increased motor heating. Higher current also increases motor torque, resulting in sharper accelerations that can jerk or stress the mechanics in your system. If you ramp up through each intermediate switch position, you can evaluate the effects on your mechanics as you gradually increase damping.

13 – CONFIGURE ELECTRONIC VISCOSITY (EV)

If you configured active damping in the previous step, you can leave the active damping rotary switch set at the value you chose. You do not need to set active damping at zero while you configure EV.

1. Verify that the EV Rotary Switch is Set at Zero

EV is *off* when the switch is in the zero position.

2. Make a Move With EV Turned Off

Notice the sound, amount of motor vibration, perceptible ringing, etc. This is your baseline move. It shows how your system operates with EV off. Each time you adjust this switch, you will compare results with this baseline move.

Remember, EV only works below 3 rps. Select a move that is representative of your application, with similar velocity and acceleration.

3. Turn On EV

Turn the rotary switch to position 1. This turns on EV.

You can change the switch setting “on the fly,” while the move is in progress. You do not need to cycle power each time you change the switch setting. For repetitive moves, you can change the switch setting while the move is in progress. This allows you to immediately evaluate the results, and compare two different settings.

4. Make a Move With EV Turned On

Compare results to the baseline move.

5. Increase the Switch Setting

Turn the switch to the next higher position. Make the move. Notice the results, and compare them to earlier settings.

6. Find the Ideal Switch Setting

Repeat *Step 5* until you find the setting that gives the best performance. You can try all seven switch settings. Incorrect switch settings will not cause damage.

CHAPTER THREE

Troubleshooting

IN THIS CHAPTER

- Troubleshooting Basics
 - Diagnostic LEDs
 - Protective Circuits
 - Automatic Test
 - Anti-Resonance Disable
 - Product Return Procedure
-

TROUBLESHOOTING BASICS

When your system does not function properly (or as you expect it to operate), the first thing that you must do is identify and isolate the problem. When you have accomplished this, you can effectively begin to resolve the problem.

The first step is to isolate each system component and ensure that each component functions properly when it is run independently. You may have to dismantle your system and put it back together piece by piece to detect the problem. If you have additional units available, you may want to exchange them with existing components in your system to help identify the source of the problem.

Determine if the problem is mechanical, electrical, or software-related. Can you repeat or recreate the problem? Random events may appear to be related, but they are not necessarily contributing factors to your problem.

You may be experiencing more than one problem. You must isolate and solve one problem at a time. Log (document) all testing and problem isolation procedures. You may need to review and consult these notes later. This will also prevent you from duplicating your testing efforts.

Once you have isolated a problem, take the necessary steps to resolve it. Refer to the problem solutions contained in this chapter. If the problem persists, contact your local technical support resource.

DIAGNOSTIC LEDs

The ZETA4-240 Drive has four LEDs on its front panel. The following summary of LED functions may help you isolate problems.

<u>LED Name</u>	<u>Color</u>	<u>Function</u>
POWER	Green	Illuminates when AC power is applied Off if AC power is under voltage (<95VAC)
STEP	Green Red/Green	Illuminates with each applied step pulse Alternates red & green during Auto Test
OVER TEMP	Red	Indicates drive has exceeded temperature limit
MOTOR FAULT	Red	Indicates short circuit in motor or cabling Indicates open interlock

PROTECTIVE CIRCUITS

The ZETA4-240 Drive has several protective circuits, some of which can indicate fault conditions by illuminating one of the above LEDs.

OVERTEMPERATURE PROTECTION

To protect against damage from high temperatures, the ZETA4-240 Drive has an internal temperature sensor. If the sensor reaches 55°C (131°F) it will trigger an overtemperature fault. The red **OVER TEMP** LED will illuminate, and the drive will shut down. This is a latched fault. To restart the

drive, first allow it to cool, then cycle power or toggle the reset input.

SHORT CIRCUIT PROTECTION

The ZETA4-240 Drive has short circuit protection. When the drive detects a short circuit in the motor or motor cabling, it illuminates the **MOTOR FAULT LED**, and stops producing motor current. This is a latched condition. To restart the drive, first fix the short in the motor or cable, then cycle power.

REGENERATION

The ZETA4-240 Drive has an internal regeneration resistor. If the motor *regenerates*—produces excess energy during deceleration—the drive will automatically dissipate the excess energy in its regeneration resistor. If the motor regenerates an excess amount of energy on a continuous basis, the drive's internal temperature may rise and trigger an overtemperature fault (see above).

AUTOMATIC TEST

Often in diagnosing a problem, it is helpful to rule out possible causes. If you disconnect the load and indexer from the drive, four components remain—the drive, motor, motor cable, and power cable.

You can then configure the drive to run its automatic test. See instructions near the beginning of *Chapter 2 Installation*, under *Quick Test*. If the motor turns as expected—counterclockwise at approximately one rps—then the drive, motor, and cables are probably not the cause of the problem. The cause may lie with the indexer, limit switches, mechanics, etc.

ANTI-RESONANCE DISABLE

If your mechanical system is highly resonant at precisely the *wrong* frequency, anti-resonance might interpret the mechanical vibrations as rotor position error. You would notice greater torque ripple, increased audible noise, and possibly even stalling. To solve these problems, try adjusting the anti-resonance phase and gain (SW2-#3 & #4), or try disabling anti-resonance (SW2-#2 on), and see if the problems improve.

You can also turn on and use active damping. The drive automatically disables anti-resonance when active damping is turned on.

TECHNICAL SUPPORT

If you cannot solve your system problems using this user guide, contact your local Automation Technology Center (ATC) or distributor for assistance. If you need to talk to our in-house application engineers, contact Parker Compumotor's Applications Department at (800) 358-9070, from 6:00 AM to 5:00 PM Pacific time.

PRODUCT RETURN PROCEDURE

If you must return your ZETA4-240 Drive for repairs, use the following steps:

1. Get the serial number and the model number of the defective unit, and a purchase order number to cover repair costs in the event the unit is determined to be out of warranty.
2. Before you return the unit, have someone from your organization with a technical understanding of the ZETA4-240 Drive and its application include answers to the following questions:
 - What is the extent of the failure/reason for return?
 - How long did the unit operate?
 - Did any other items fail at the same time?
 - What was happening when the unit failed (e.g., installing the unit, cycling power, starting other equipment, etc.)?
 - How was the unit configured (in detail)?
 - What, if any, cables were modified and how?
 - With what equipment is the unit interfaced?
 - What was the application?
 - What was the system environment (temperature, enclosure, spacing, unit orientation, contaminants, etc.)?
 - What upgrades, if any, are required (hardware, cables, user guide)?
3. In the USA, call your Automation Technology Center (ATC) for a Return Material Authorization (RMA) number. Returned products cannot be accepted without an RMA number. If you cannot obtain an RMA number from your ATC, call Parker Compumotor's Customer Service Department at (800) 722-2282.

Ship the unit to: Parker Hannifin Corporation
 Compumotor Division
 5500 Business Park Drive, Suite D
 Rohnert Park, CA 94928
 Attn: RMA # xxxxxxxx

4. In the UK, call Parker Digiplan for a GRA (Goods Returned Authorization) number. Returned products cannot be accepted without a GRA number. The phone number for Parker Digiplan Repair Department is 0202-690911. The phone number for Parker Digiplan Service/Applications Department is 0202-699000.

Ship the unit to: Parker Digiplan Ltd.,
 21, Balena Close,
 Poole, Dorset,
 England. BH17 7DX

5. Elsewhere: Contact the distributor who supplied the equipment.

A P P E N D I X A

Using Non-Compumotor Motors

IN THIS APPENDIX

- Wiring Configurations: 4-, 6- and 8-lead motors
 - Terminal Connections: 4-, 6- and 8-lead motors
 - Setting Motor Current: Series or Parallel
Unipolar or Bipolar
-

USING NON-COMPUMOTOR MOTORS

When the ZETA4-240 Drive operates from a nominal 240VAC input, its rectified output is approximately 370VDC. We recommend you use Compumotor R Series motors, which are designed to operate at 370VDC. If you use a non-R Series motor, it must meet the following specifications:

- Motor must be able to withstand 370VDC input voltage.
- Motor must have a minimum 1900VDC high-pot insulation rating from phase-to-phase and phase-to-ground.
- Motor must have a minimum inductance of 2 mH, series or parallel. (Compumotor recommends a minimum inductance of 5 mH.)
- Motor must be designed for use with a bipolar drive (no common center tap).
- Motor must not have riveted rotors or stators.
- Do not use solid rotor motors.
- Test all motors carefully. Verify that the motor temperature in your application is within the system limitations. *The motor manufacturer's maximum allowable motor case temperature must not be exceeded.* You should test the motor over a 2-to-3 hour period. Motors tend to have a long thermal time constant, but can still overheat, which results in motor damage.

CAUTION

Consult your motor vendor to verify that your motor meets the above specifications. Consult your Automation Technology Center (ATC) if you have questions regarding the use of a non-Compumotor motor with Compumotor equipment.

WIRING CONFIGURATIONS

Refer to the manufacturer's motor specification document to determine the motor's wiring configuration. You can also determine the wiring configuration with an ohmmeter using the procedures below (*4-Lead Motor, 6-Lead Motor, 8-Lead Motor*). Once you determine the correct motor wiring configuration, use the terminal connection diagram, shown at the end of this section, that applies to your configuration.

4-LEAD MOTOR

1. Label one motor lead **A+**.
2. Connect one lead of an ohmmeter to the **A+** lead and touch the other lead of the ohmmeter to the three remaining motor leads until you find the lead that creates continuity. Label this lead **A-**.
3. Label the two remaining leads **B+** and **B-**. *Verify that there is continuity between the **B+** and **B-** leads.*
4. Proceed to the *Terminal Connections* section below.

6-LEAD MOTOR

1. Determine, with an ohmmeter, which three of the six motor leads are common (one phase).
2. Label each one of these three motor leads **A**.
3. Using the ohmmeter, verify that the remaining three leads are common.
4. Label the remaining three leads **B**.
5. Set the ohmmeter range to the 100 ohm scale (approximately).
6. Connect the ohmmeter's negative lead to one of the motor leads labeled **A**. Alternately measure the resistance to the two remaining motor leads also labeled **A**. The measurements will reflect one of the following two scenarios.
Scenario #1 — The resistance measurements to the two remaining motor leads are virtually identical. Label the two remaining motor leads **A+** and **A-**. Label the motor lead connected to the negative lead of the ohmmeter **A-CT** (this is the *center tap*, or common lead for Phase A of the motor).

Scenario #2 — The resistance measurement to the second of the three motor leads measures 50% of the resistance measurement to the third of the three motor leads. Label the second motor lead **A-CT** (this is the *center tap*, or common lead for Phase A of the motor). Label the third motor lead **A-**. Label the motor lead connected to the ohmmeter **A+**.

7. Repeat the procedure as outlined in step 6 for the three leads labeled **B** (**B-CT** is the *center tap*, or common lead for Phase B of the motor).
8. Proceed to the *Terminal Connections* section below.

8-LEAD MOTOR

Because of the complexity involved in phasing an 8-lead motor, you must refer to the manufacturer's motor specification document. Using the manufacturer's specifications, label the motor leads as shown in the next drawing.

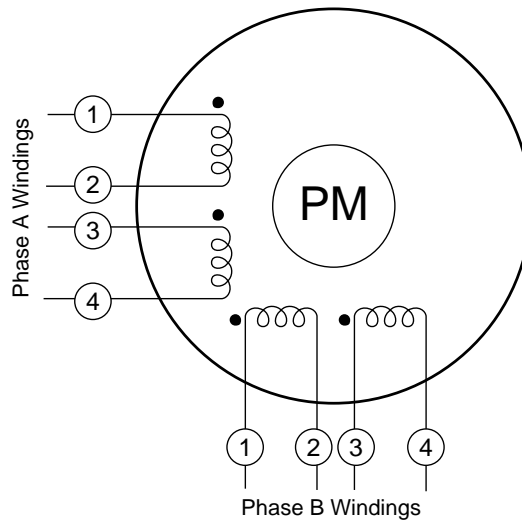

8-Lead Motor – Labeling the Leads

You can configure the 8-lead motor in series or parallel.

Series Configuration Use the following procedure for series configurations.

1. Connect A2 & A3 together and relabel this common point **A-CT**.
2. Connect B2 & B3 together and relabel this common point **B-CT**.
3. Relabel the A1 lead **A+**.
4. Relabel the A4 lead **A-**.
5. Relabel the B1 lead **B+**.
6. Relabel the B4 lead **B-**.
7. Proceed to the *Terminal Connections* section below.

Parallel Configuration Use the following procedure for parallel configurations.

1. Connect motor leads A1 & A3 together and relabel this common point **A+**.
2. Connect motor leads A2 & A4 together and relabel this common point **A-**.
3. Connect motor leads B1 & B3 together and relabel this common point **B+**.
4. Connect motor leads B2 & B4 together and relabel this common point **B-**.
5. Proceed to the *Terminal Connections* section below.

TERMINAL CONNECTIONS

After you determine the motor's wiring configuration, connect the motor leads to the ZETA4-240 Drive's 7-pin MOTOR connector according to the following figure.

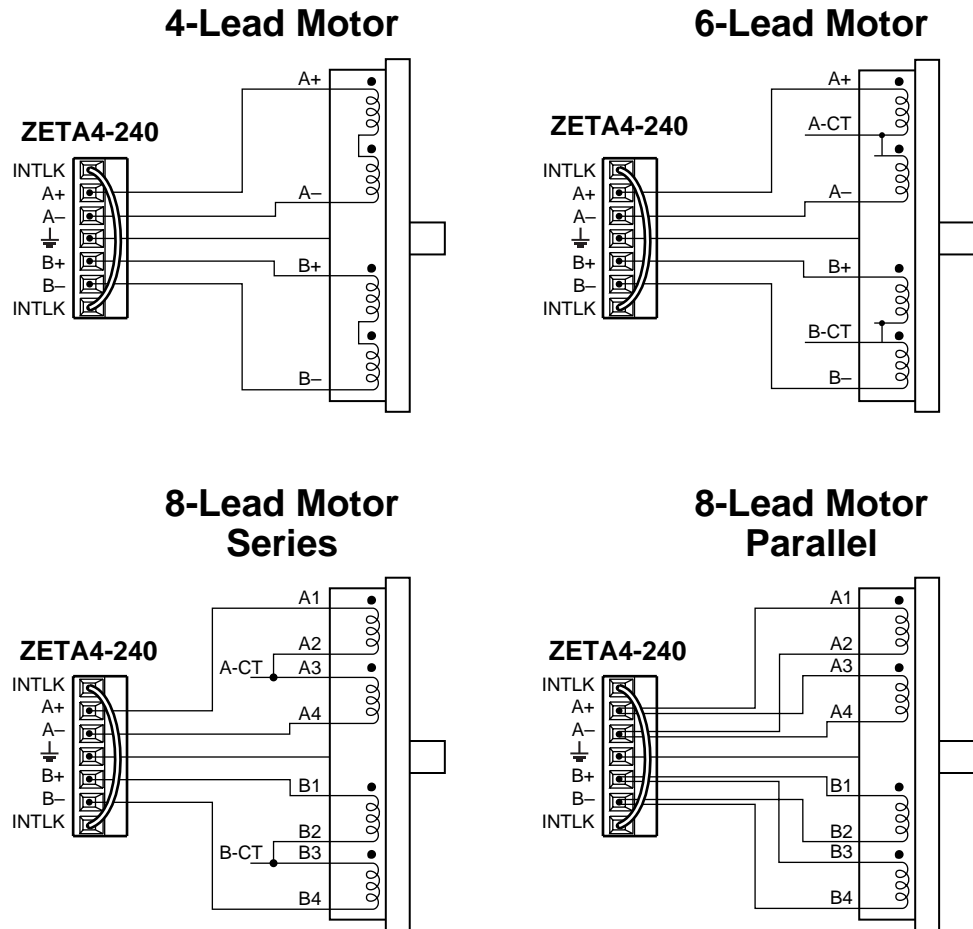

Non-Compumotor Motor Connections

DIRECTION OF MOTOR ROTATION

The procedures above do not determine the direction of motor shaft rotation. To find out which direction the shaft turns, you must power up your system and command motion. If the shaft turns in the opposite direction than you want, exchange the motor leads connected to **A+** and **A-** to reverse the direction of rotation.

WARNING

Motor shaft rotation may be opposite than you expect. Do not connect a load to the shaft until you first determine the direction of shaft rotation.

The *Automatic Test*, described near the beginning of *Chapter 2, Installation*, provides a simple method of determining motor shaft rotation. The test causes the shaft to rotate in the counterclockwise (negative) direction, if the motor wires are properly connected. No indexer is required to perform the automatic test.

SETTING MOTOR CURRENT – NON-COMPUMOTOR MOTORS

To set motor current for a non-Compumotor motor, refer to the formulas below that correspond to your motor (4-lead, 6-lead, 8-lead) and use the current settings shown in the DIP switch table (in *Chapter 2, Installation*) to set the motor's current.

WARNING

Do not connect or disconnect the motor with the power on. Doing so will damage the contacts of the motor connector and may cause injury to personnel.

4-LEAD MOTORS

If you use a 4-lead motor, the manufacturer's current specification will translate directly to the values shown for current in the DIP switch table.

6-LEAD MOTORS

Manufacturers generally use either a bipolar rating or a unipolar rating for motor current in 6-lead motors.

Bipolar Rating: If the manufacturer specifies the motor current as a bipolar rating, you can use the DIP switch table's current settings directly to set motor current—no conversion is required.

Unipolar Rating: If the manufacturer specifies the motor current as a unipolar rating:

- Use the following formula to convert the unipolar current rating to the correct bipolar rating:

$$\text{Unipolar Current} * 0.707 = \text{Bipolar Current}$$

- Use the converted value and the DIP switch table's current settings to set the motor current.

8-LEAD MOTORS

Manufacturers generally use either a bipolar rating or a unipolar rating for motor current in 8-lead motors.

Bipolar Rating: If the manufacturer specifies the motor current as a bipolar series rating:

- If you wire the motor in **series**, use the DIP switch table's current settings directly.
- If you wire the motor in **parallel**, you must double the manufacturer's rating and then use the DIP switch table's current settings to set the motor current.

Unipolar Rating: If the manufacturer specifies the motor current as a unipolar rating:

- Use the following formula to convert the unipolar current rating to the correct bipolar rating:

$$\text{Unipolar Current} * 0.707 = \text{Bipolar Current}$$

- If you wire the motor in **series**, use the converted value and the DIP switch table's current settings to set the motor current.
- If you wire the motor in **parallel**, you must **double** the converted value and use the DIP switch table's current settings to set the motor current.

If you have questions about setting motor current, call Compumotor's Applications Engineering Department at (800) 358-9070.

APPENDIX B

LVD and EMC Installation Guide

IN THIS APPENDIX

- LVD Installation Instructions
 - EMC Installation Instructions
-

GENERAL INSTRUCTIONS

When installed according to the instructions in this user guide and this appendix, the ZETA4-240 Drive will comply with requirements set forth by the European Union with regard to product safety (Low Voltage Directive, 73/23/EEC) and electromagnetic compatibility (EMC, 89/336/EEC).

Two kits are available from Compumotor to facilitate installation:

- **C10 Cable Kit** – Includes motor cable and associated hardware. Allows the use of CE marked (LVD) step motors with 1/2" NPT or PG11 cable entry with the ZETA4-240
- **EMC Kit** – Includes mains (AC line) filter and EMC indexer-to-drive cable (Compumotor standard pinout 15M-to-25M pin D-shell)

In this appendix, we assume you are using a Compumotor R Series motor, C10 Cable Kit, and EMC Kit. When installed with these options, the ZETA4-240 Drive has been demonstrated to meet Electromagnetic Compatibility Standard and the Low Voltage Directive requirements.

When properly installed, the ZETA4-240 Drive is *not required* to be mounted within a screened enclosure (cabinet) to achieve compliance. The ultimate responsibility for ensuring that the EMC requirements are met rests with the systems builder.

If you use non-Compumotor equipment, see Compumotor's *EMC Installation Guide* for additional instructions on meeting EMC requirements.

LOW VOLTAGE DIRECTIVE (LVD) INSTALLATION INSTRUCTIONS

For more information about LVD, see 73/23/EEC and 93/68/EEC, published by the European Economic Community (EEC).

ENVIRONMENTAL CONDITIONS

POLLUTION DEGREE

The ZETA4-240 Drive is designed for pollution degree 2.

INSTALLATION CATEGORY

The ZETA4-240 Drive is designed for installation category II.

ELECTRICAL

CONNECTING AND DISCONNECTING POWER

The ZETA4-240 accepts mains input voltage from 95 – 264VAC, at 47-63 Hz. Maximum power consumption is shown in *Chapter 2, Installation*, under *Connect AC Power*.

The ZETA4-240 ships with a molded 3-conductor IEC plug. Wire this plug in accordance with local regulations.

The ZETA4-240 Drive's protective earth connection is provided through its AC power connector. You must reliably earth the ZETA4-240 Drive's protective earth connection.

The ZETA4-240 Drive's supply voltage is limited to 264VAC.

CONNECTING THE PROTECTIVE CONDUCTOR TERMINAL TO EARTH

You must provide a connection from the ZETA4-240 Drive's protective conductor terminal to a reliable system earth point.

The protective conductor terminal is marked with a label on the product bearing the following symbol:



Protective Conductor Terminal Marking

Follow these steps to connect the protective conductor terminal to earth:

1. For compliance with LVD, you must use a VDE approved green/yellow protective conductor terminal wire to reliably earth the protective conductor terminal. Wire gauge must be no thinner than the current-carrying wire in the product's mains supply.
3. Resistance between the protective conductor terminal and earth must be no greater than 0.1 ohms. Use thicker gauge wire if the resistance is too high.

PROVIDING A PROTECTIVE EARTH CONNECTION FOR MOTORS

You must provide a connection from the motor to a reliable protective earth. This connection provides a protective earth for the motor contact point. The motor's protective earth connection is important for safety reasons, and *must not be omitted*.

Compumotor's R Series motors with the C10 Cable option have a protective conductor in the removable cable. The ZETA4-240 grounds the motor through its motor connector.

If you use a motor without a protective conductor, make connections according to the following instructions and diagram:

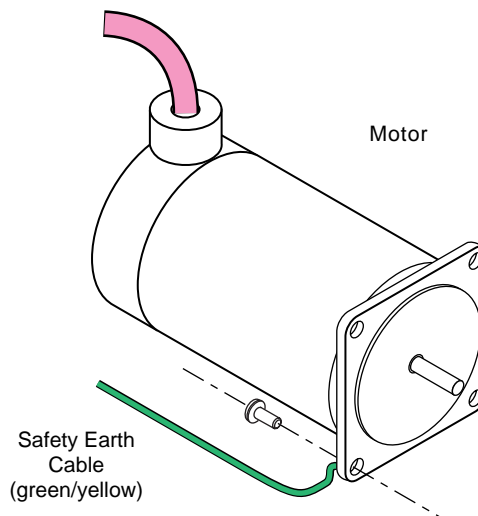

Motor – Earth Connection

1. Use a ring terminal with a star washer and mounting bolt to make good contact with the bare metal surface of the motor's mounting flange.
2. Use a VDE approved green/yellow protective conductor terminal wire to make the connection between the motor and earth. Wire gauge must be no thinner than the current carrying wire in the motor's power cable.
3. Resistance between the motor and earth must be no greater than 0.1 ohms. Use thicker gauge wire if the resistance is too high.

EXTENDING MOTOR CABLES

Compumotor's C10 Motor Cable is 10 feet (3 m) long. Longer cable lengths are not available from Compumotor. If you extend the motor cable, follow the appropriate guidelines in the LVD regulations published by the EEC.

THERMAL SAFETY

THE MOTOR MAY BE HOT

The motor may reach high temperatures during normal operations, and may remain hot after power is removed.







SONIC PRESSURE

HIGH SOUND LEVEL

The sound level from some large frame step motors (NEMA 34, NEMA 42, and larger) may exceed 85 dBA. Actual sound level is application dependent, and varies with motor loads and mounting conditions. Measure the sound level in your application; if it exceeds 85 dBA, install the motor in an enclosure to provide sound baffling, or provide ear protection for personnel.

TABLE OF GRAPHIC SYMBOLS AND WARNINGS

The following symbols may appear in this user guide, and may be affixed to the products discussed in this user guide.

Symbol	Description
	Earth Terminal
	Protective Conductor Terminal
	Frame or Chassis Terminal
	Equipotentiality
	Caution, Risk of Electric Shock
	Caution, Refer to Accompanying Text
	Hot Surface

EMC INSTALLATION INSTRUCTIONS

GENERAL PRODUCT PHILOSOPHY

Meeting requirements for electromagnetic compatibility (EMC) compliance requires specific measures to be taken during installation of the ZETA4-240 Drive. The ultimate responsibility for ensuring that the EMC requirements are met rests with the systems builder.

For specific installations, the full protection requirements of the EMC Directive 89/336/EEC must be met before the system is put into service. This must be verified either by inspection or by testing. The following EMC installation recommendations are intended to assist in ensuring that the requirements of the EMC directive are met. It may be necessary to take additional measures in certain circumstances and at specific locations.

It is important to follow **all** the installation instructions to achieve an adequate level of compliance.

SAFETY CONSIDERATIONS

These products are intended for installation according to the appropriate safety procedures including those laid down by the local supply authority regulations. The recommendations provided are based on the requirements of the Low Voltage Directive and specifically on EN60204. Safety must never be compromised for the purpose of achieving EMC compliance. In the event of a conflict occurring between the safety regulations and the following recommendations, **the safety regulations always take precedence.**

ZETA4-240 INSTRUCTIONS

We assume you are using:

- Compumotor R Series Motor
- C10 Cable Kit (provides motor cable, gland, R-clamp with screw)
- EMC Kit (provides AC mains filter, EMC indexer cable)

If you use non-Compumotor parts for your installation, see Compumotor's *EMC Installation Guide* for additional instructions on meeting EMC requirements.

MOUNTING

The ZETA4-240 Drive must be mounted to a conductive, earthed panel. Before mounting the drive, ensure that the mounting location is flat and free from paint or other nonconductive surface coatings. If necessary, remove paint from the mounting surface. This should guarantee a good high-frequency connection between the drive case and the mounting surface. After mounting the unit use petroleum jelly on the exposed metal to minimize the risk of future corrosion.

FILTERING THE AC MAINS

In most installations, the AC mains will require fitting of a mains filter. Recommended filters for use with the ZETA4-240 Drive are

Recommended AC Input Filter:

CORCOM part number 10EP1	SCHAFFNER part number FN2070-10-06
Corcom World Headquarters	Schaffner EMC Inc.
Phone: 847-680-7400	Phone: 201-379-7778
Fax: 847-680-8169	Fax: 201-379-1151

You will need one of these filters for each drive. Compumotor's EMC Kit includes a suitable AC mains filter.

Mount the filter as close as possible to the drive's AC input connector (see the figure *EMC Compliant Installation* at the end of this section). Ensure that there is no paint on the mounting panel under the filter—a large-area conductive contact between the filter and the panel is vital.

Connect the incoming AC supply cable to the push-on terminals on the filter, with the earth lead connected to a local earth stud, bus bar or metal backplane. Route the supply cable so that it runs close to the walls of the enclosure. Connect the earth terminal on the filter case to the earth stud.

Route these wires away from motor cables and other high current cabling, while keeping their length as short as possible.

MOTOR CONNECTIONS – R SERIES MOTOR WITH C10 OPTION

The C10 option for Compumotor's R Series motors includes a removable braided cable and all necessary hardware for making an EMC compliant installation. Instructions for attaching the cable follow.

The C10 Motor Cable is 10 feet (3 m) long. Longer cable lengths are not available from Compumotor. If you extend the motor cable, follow the appropriate guidelines in the LVD regulations published by the EEC.

CAUTION

At no time during the following procedure should the motor cable be allowed to twist within the gland assembly. This can damage the cable and greatly reduce its life.

Procedure for Attaching C10 Cable to R Series Motor and ZETA4-240 Drive

1. Inventory (ship kit contents are listed below and shown in next drawing)

- Thread converter
- Gland assembly (5 pieces)
- Motor cable, 10 ft. (3 m)
- R-Clamp with 6-32 x 1/2 inch screw

Required Assembly Hardware:

- Phillips screwdriver #2
- Wire strippers
- Standard slotted screwdriver, approximately 0.25 in (6 mm)
- Crimp-on ring terminals sized for 18AWG (0.75 mm) wire:
 - 9 required for series wiring
 - 13 required for parallel wiring
- 18AWG (0.75 mm) wire jumpers 4 in (100 mm) long:
 - 2 required for series wiring
 - 4 required for parallel wiring
- Crimp tool
- Open end 15/16-inch wrench

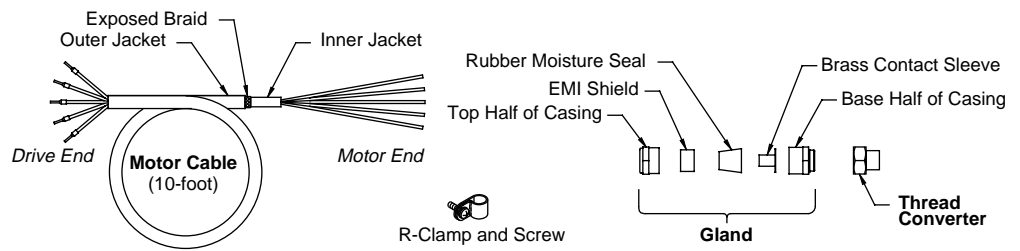

2. Install Thread Converter and Casing Base

- A. Remove and discard the motor's plastic thread insert (CCW rotation)
- B. Remove endbell cover plate from the rear of the motor.
- C. Insert the thread converter into the motor rear endbell, and tighten. The NPT thread is designed for compression fit into the motor body and therefore will not bottom out.
- D. Insert the base half of the outer casing into the thread converter and tighten securely.

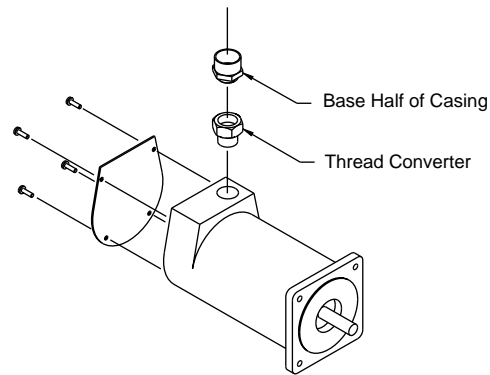

3. Arrange Components on Cable

- A. From the motor end of the cable, first slide on the dome casing half, then the EMI shield, and finally the rubber moisture seal. The EMI shield is installed blunt end first. The tapered end of the EMI shield fits over the tapered end of the rubber moisture seal.
- B. **The next step is critical and if not done properly will impair the EMC performance of the system:**
 With a finger tip, flare the braid away from the inner jacket of the cable (all the way around). This will allow the braid to relax, and eases insertion of the brass sleeve.
- C. Carefully slide the brass sleeve as far under the exposed braid as possible. The sleeve must not cause the braid to bunch up or slide up under the outer jacket. The sleeve flange should butt up against the inner jacket of the cable.

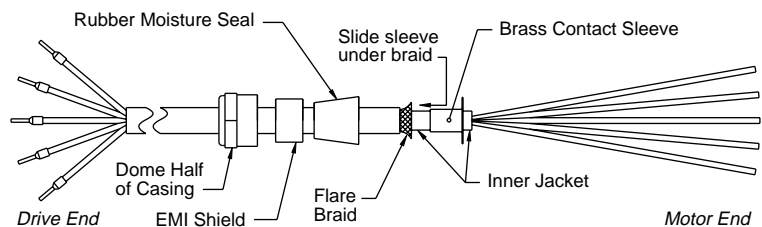

4. Assemble Components on Cable

- A. Slide the rubber moisture seal up to the flange of the brass sleeve.
- B. Slide the EMI shield onto the rubber moisture seal.
- C. Slide the dome half of the outer casing over the EMI shield

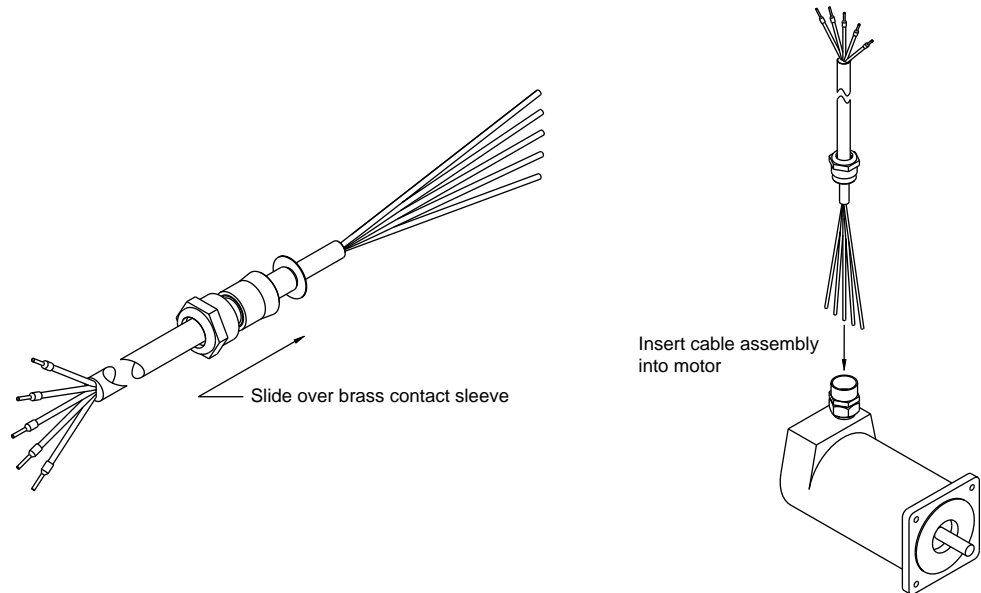

5. Insert Cable Assembly into Motor

Insert the assembly into the prepared motor and screw the dome half to the base half of the outer casing until snug. **Do not twist the cable.**

6. Wire Motor for Series or Parallel Operation.

Wire the motor as instructed in *Chapter 2*, in the section *Choose Series or Parallel Motor Wiring*. Install the end bell cover plate onto the rear of the motor.

7. Connect the Cable to the ZETA4-240 Drive

At the drive end of the motor cable, expose a short length of braiding and anchor the cable to the ZETA4-240 Drive with the R-clamp and screw included in the C10 Cable Kit. Avoid looping the motor cable. The motor cable should be kept away from I/O cables carrying control signals.

The next figure shows dimensions for your cable preparation.

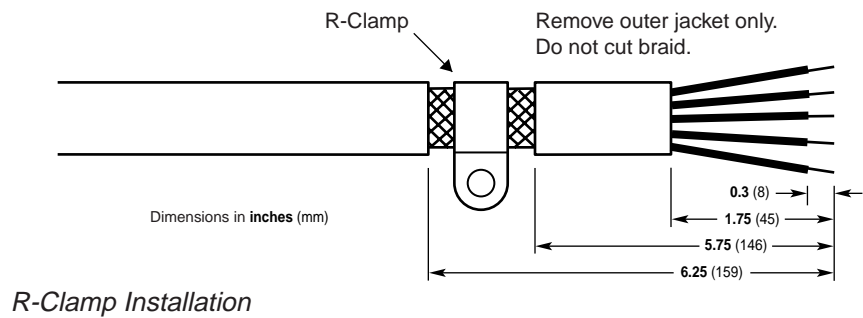

INDEXER CONNECTIONS

Compumotor's EMC Kit includes an EMC version of the indexer-to-drive cable, with Compumotor's standard 15M-to-25M pin D-shell connectors. This cable has a 360° braided shield, and twisted pair wires. Plug the cable into the ZETA4-240 Drive and your Compumotor indexer.

INSTALLATION DRAWING

The next drawing shows a typical EMC compliant installation.

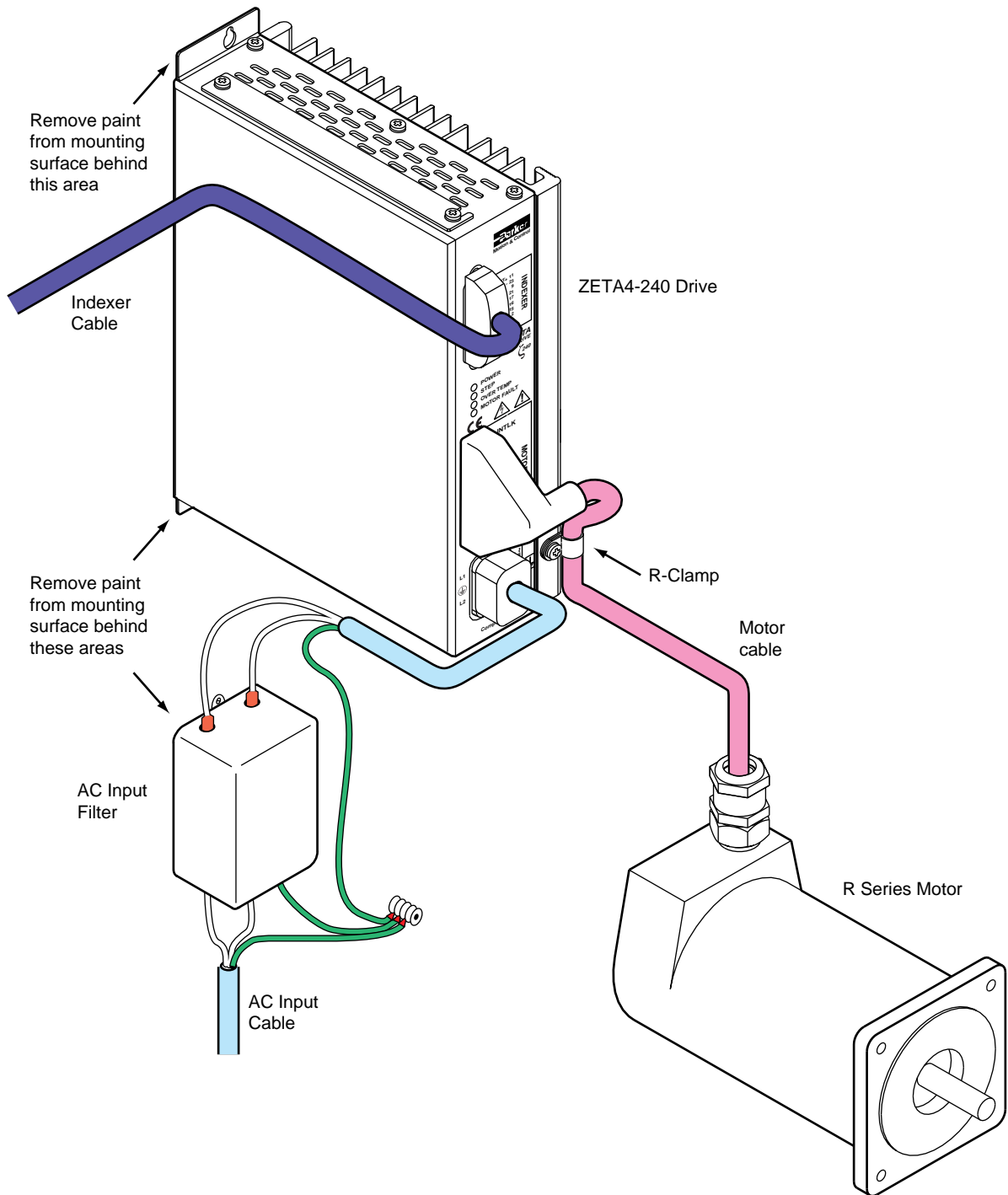

APPENDIX C

120VAC Operation

IN THIS APPENDIX

- Motor Information
 - Drive Information
 - EMC Considerations
-

IN THIS APPENDIX

In this appendix, we give information for using the ZETA4-240 Drive at 120VAC, with Compumotor's O and R Series motors with "B" (120V) windings.

Topics are presented in the same order in which they occur in the user guide.

SPEED/TORQUE CURVES FOR O AND R SERIES MOTORS AT 120VAC

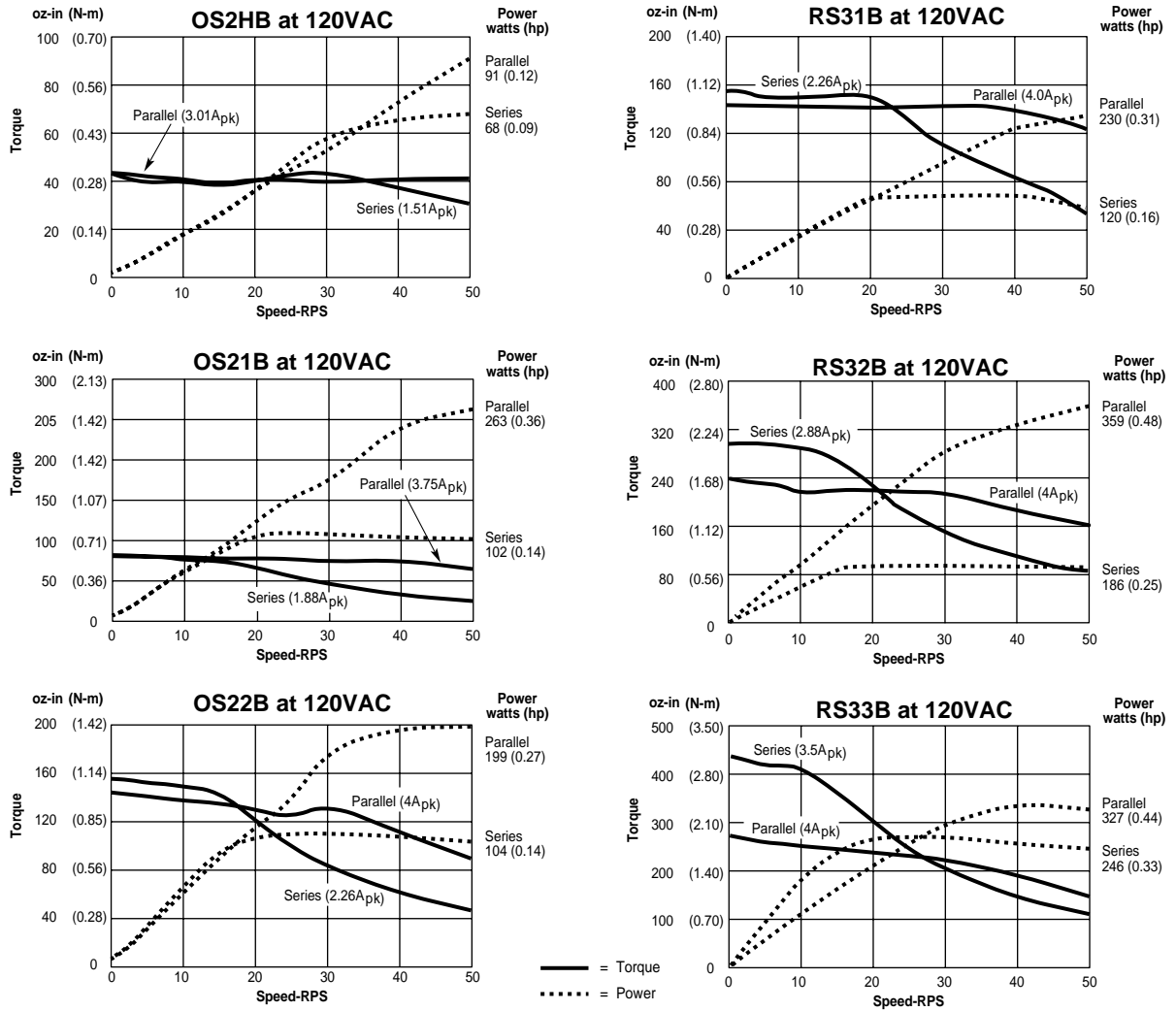

Note 1: Parallel connected motors are limited to 50% duty cycle when operated above 5 rps. For greater than 50% duty cycle above 5 rps, you must connect the motor in series. Fan cooling the motor will increase duty cycles above 5 rps.

Note 2: Viscous damper is not required to achieve speed torque curves.

Note 3: ±10% torque variance due to motor tolerance .

Speed/Torque Curves for O and R Motors with ZETA2-240 Drive at 120VAC

MOTOR SPECIFICATIONS – O AND R MOTORS

	Size 23 OS Motors			Size 34 RS Motors		
	OS2HB	OS21B	OS22B	R31B	RS32B	RS33B
Static torque						
oz-in	43	82	155	141	292	382
(N-m)	(0.30)	(0.58)	(1.09)	(1.00)	(2.06)	(2.70)
Rotor inertia						
oz-in ²	0.386	0.656	1.390	3.204	6.563	9.652
(kg-cm ²)	(0.070)	(0.119)	(0.253)	(0.583)	(1.195)	(1.757)
Bearings – Thrust load						
lb	13	13	13	180	180	180
(kg)	(5.9)	(5.9)	(5.9)	(81.6)	(81.6)	(81.6)
Bearings – Radial load						
lb	20	20	20	35	35	35
(kg)	(9.1)	(9.1)	(9.1)	(15.9)	(15.9)	(15.9)
Bearings – End play (reversing load equal to 1 lb)						
in	0.001	0.001	0.001	0.001	0.001	0.001
(mm)	(0.025)	(0.025)	(0.025)	(0.025)	(0.025)	(0.025)
Bearings – Radial play (per 0.5 lb load)						
in	0.0008	0.0008	0.0008	0.0008	0.0008	0.0008
(mm)	(0.02)	(0.02)	(0.02)	(0.02)	(0.02)	(0.02)
Motor Weight (motor + cable + connector)						
lb	1.0	1.5	2.5	3.2	5.3	7.6
(kg)	(0.45)	(0.68)	(1.14)	(1.45)	(2.41)	(3.45)
Certifications						
UL recognized	no	no	no	yes	yes	yes
CE (LVD)	yes	yes	yes	yes	yes	yes
CE (EMC & LVD)	no	no	no	*	*	*

*EMC is achievable with C10 Cable Kit and EMC Kit

MOTOR DIMENSIONS

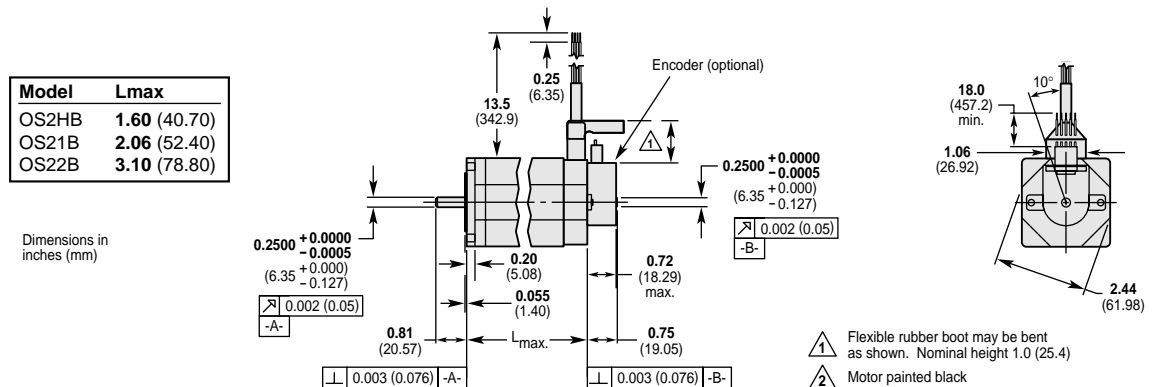

Dimensions – O Series Motors (with 120VAC windings)

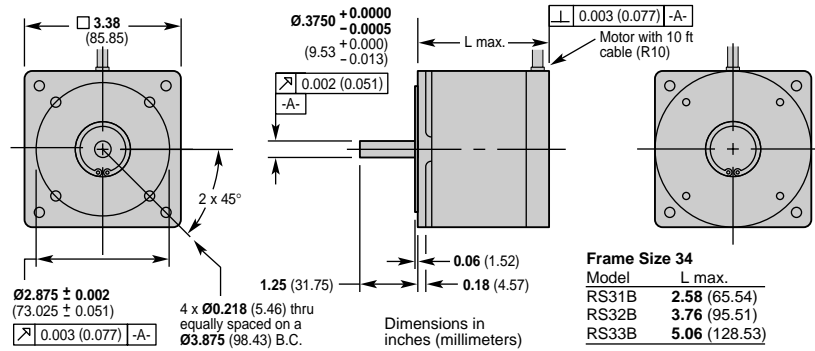

Dimensions – R Series Motors, Regular Construction (with 120VAC windings)

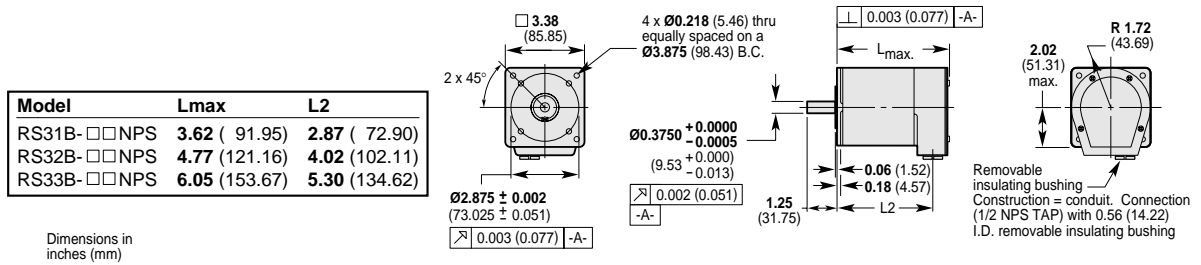

Dimensions in inches (mm)

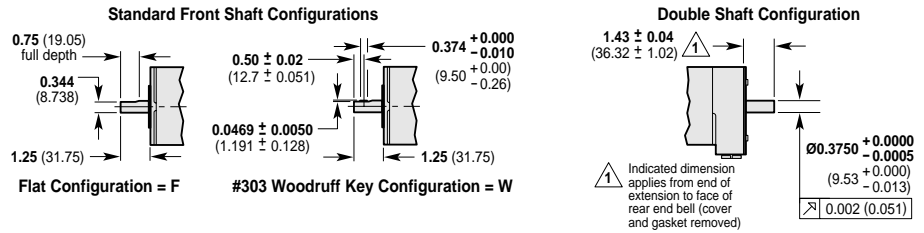

Dimensions – R Series Motors, End Bell Construction (NPS) (with 120VAC windings)

COLOR CODE – O AND R MOTORS

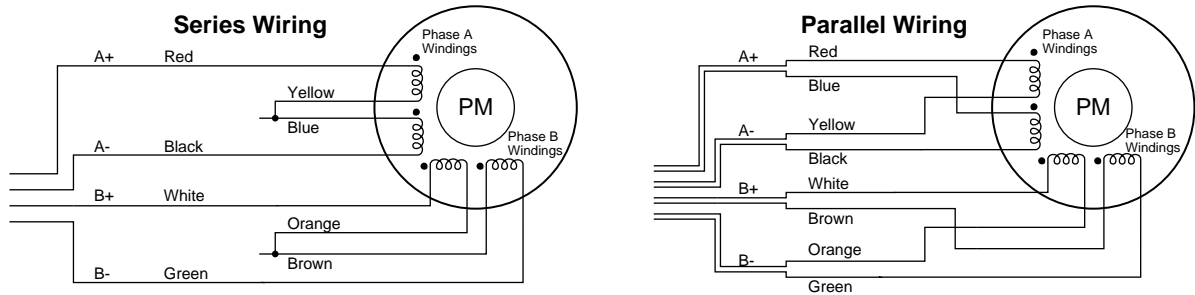

Color Code – O and R Motors

DIP SWITCH SETTINGS

Settings for current, inductance, and static torque are shown below for the ZETA4-240 Drive with Compumotor O and R Series Motors.

DIP SWITCH SETTINGS for 120VAC

off ↑

SW 1

1 12

SW 2

↑ off

← Shown Configured for OS2HB(S) Motor

Current (amps pk)					Static Torque ^{3,4}				
	1	2	3	4	5	9	10	11	12
0.14	off	off	off	off	off				
0.26	off	off	off	off	on				
0.39	off	off	off	on	off				
0.51	off	off	off	on	on				
0.64	off	off	on	off	off				
0.76	off	off	on	off	on				
0.89	off	off	on	on	off				
1.01	off	off	on	on	on				
1.14	off	on	off	off	off				
1.26	off	on	off	off	on				
1.38	off	on	off	on	off				
OS2HB(S)	1.51	off	on	off	on				
	1.63	off	on	on	off				
	1.76	off	on	on	off				
OS21B(S)	1.88	off	on	on	on				
	2.01	off	on	on	on				
OS22B(S)	2.14	on	off	off	off				
RS31B(S)	2.26	on	off	off	off				
	2.38	on	off	off	on				
	2.51	on	off	off	on				
	2.63	on	off	on	off				
	2.76	on	off	on	off				
RS32B(S)	2.88	on	off	on	on				
OS2HB(P)	3.01	on	off	on	on				
	3.13	on	on	off	off				
	3.26	on	on	off	off				
	3.38	on	on	off	on				
RS33B(S)	3.50	on	on	off	on				
	3.63	on	on	on	off				
OS21B(P)	3.75	on	on	on	off				
OS22B(P)	3.88	on	on	on	on				
RS3xB(P) ¹	4.00	on	on	on	on				

Resolution ² (steps per revolution)		6	7	8	9
50,800 steps	Default Setting	off	off	off	on
50,000 steps		off	off	on	off
36,000 steps		off	off	on	on
25,600 steps		off	on	off	off
25,400 steps		off	on	off	on
25,000 steps		off	off	off	off
21,600 steps		off	on	on	off
20,000 steps		off	on	on	on
18,000 steps		on	off	off	off
12,800 steps		on	off	off	on
10,000 steps		on	off	on	off
5,000 steps		on	off	on	on
2,000 steps		on	on	off	off
1,000 steps		on	on	off	on
400 steps		on	on	on	off
200 steps		on	on	on	on

Waveform ² Default Setting	10	11
-4% 3rd harmonic	off	off
-10% 3rd harmonic	off	on
-6% 3rd harmonic	on	off
Pure sine	on	on

Automatic Test ²	6	7	8	9	10	11
	on	on	on	on	on	on

S&D/CW&CCW ²	12
Step & Direction Indexer	off
Clockwise & Counterclockwise Indexer	on

Inductance ^{3,4}	
7	8
off	off
off	on
on	off
on	on

System Inertia	
6	5
off	Less than 20kg-cm ²
on	Greater than 20kg-cm ²

Current-Loop Gain	
5	4
off	Standard
on	Reduced

Anti-Resonance Gain	
4	3
off	Standard (system inertia < 20kg-cm ²)
on	Reduced (system inertia > 20kg-cm ²)

Anti-Resonance Phase	
3	2
off	Resonant Freq. < 200 Hz
on	Resonant Freq. > 200 Hz

Anti-Resonance Disable	
2	1
off	Anti-res. Enabled
on	Anti-res. Disabled

Automatic Standby	
1	0
off	Full Current
on	50% Current Standby

NOTES:

- RS3xB(P) can be RS31B(P), RS32B(P), RS33B(P).
- The drive reads these switches only upon power up. It reads all other switches continuously.
- These switches are read only by active damping circuit; they are ignored if active damping is off.
- Motor Part Number Suffix: (S) = Series Configuration (P) = Parallel Configuration No Suffix = Series or Parallel Configuration

RESONANCE SPEEDS FOR MATCHING MOTOR TO DRIVE

Consult the table below to find the speed at which to run the motor during the *Matching Procedure* described in *Chapter 2, Installation*. These are speeds that cause *resonance* in the unloaded motor. When the motor is running at a resonant speed, you will notice increased noise and vibration. To make resonance the most noticeable, you may need to vary the speed around the value given below for your motor. You can find the resonant speed by touching the motor lightly with your fingertips as you vary the speed. When you feel the strongest vibrations, the motor is running at resonant speed.

Motor	Offset Adjust (rps)	Balance Adjust (rps)	Waveform Adjust (rps)
OS2HB	4.52	2.26	1.13
OS21B	4.49	2.24	1.12
OS22B	4.51	2.26	1.13
RS31B	2.79	1.40	0.70
RS32B	2.72	1.36	0.68
RS33B	2.65	1.32	0.66

EXTENDING MOTOR CABLES

Compumotor O and R Series motors ship with various cable options, based upon the motor part number suffix, as follows:

- **-L10, -R10** and **-C10** motors ship with 10 ft (3 m) cables
- **-FLY** motor ships with 1 ft (0.3 m) flying leads
- **-NPS** motor does not include cable/leads; for 10 ft (3 m), use 18 AWG (0.75 mm²) wire.

LVD COMPLIANCE

Maximum DC resistance between the ZETA4-240's "earth" terminal (protective conductor terminal) and motor body must not exceed 0.1 ohm. Consider this requirement when sizing wire cross section (gauge) for extended cable lengths.

NON-LVD COMPLIANCE

Maximum extended cable length is 200 ft (61 m), but cables longer than 50 feet (15 m) may degrade performance. See table below for guidelines.

Motor Type	Max. Current (amps)	Less than 100 ft. (30 m)		100 – 200 ft. (30 – 60 m)	
		Size: AWG	mm ²	AWG	mm ²
OS2HB(S)	1.51	22	0.34	20	0.50
OS2HB(P)	3.01	22	0.34	20	0.50
OS21B(S)	1.88	22	0.34	20	0.50
OS21B(P)	3.75	20	0.50	18	0.75
OS22B(S)	2.14	22	0.34	20	0.50
OS22B(P)	4.00	20	0.50	18	0.75
RS31B (S)	2.26	22	0.34	20	0.50
RS31B (P)	4.00	20	0.50	18	0.75

(S) = Series Configuration (P) = Parallel Configuration Rated current in wire sizes shown may result in a maximum temperature rise of 10°C (18°F) above ambient.

PEAK POWER RATINGS

PEAK POWER RATINGS

The amount of power the ZETA4-240 Drive requires from your AC power source depends upon the motor you use, whether the motor is wired in series or parallel, and upon your specific application. The next table shows *peak* power requirements at 120VAC. Power required for your application may be less.

Motor Type	Current (Amps)	Cabinet Loss (W)	Peak Motor Loss (W)	Peak Shaft Power (W)	Peak Total Power (W)	Volt-Amp Rating (VA)
OS2HB (S)	1.51	21.1	67	34	122	199
OS2HB (P)	3.01	39.1	187	79	305	466
OS21B (S)	1.88	22.6	61	67	150	240
OS21B (P)	3.75	48.8	180	114	343	509
OS22B (S)	2.14	20.4	55	89	165	262
OS22B (P)	4.00	44.5	147	165	357	542
RS31B (S)	2.26	20.0	50	120	200	300
RS31B (P)	4.00	40.0	110	240	400	600
RE32B (S)	2.88	30.4	61	149	241	372
RE32B (P)	4.00	48.8	170	226	445	668
RS33B (S)	3.50	33.3	73	210	316	493
RS33B (P)	4.00	56.6	164	299	519	769

(S) = Series Configuration (P) = Parallel Configuration

EMC CONSIDERATIONS – MOTORS WITH NON-REMOVABLE CABLES

Except for the C10 cabling option used with R Series motors, Compumotor motors do not incorporate braided screen cables. This is true of O and R Series motors with the L10 option. To improve *electromagnetic compatibility* (EMC) performance, follow the suggestions below. In addition, review *Appendix B, LVD and EMC Installation Guide*.

If motor cabling is not confined within earthed conduit, shield the exposed length of cable and properly bond it to earth. In installations where the motor cable is within earthed conduit for the entire length of travel, the standard motor cable can be used.

To extend motor cables, cut off cable in excess of approximately 4 inches (10 cm). Configure the motor for series or parallel operation and attach braided screen cable to the motor. We recommend using a terminal block or other hardware, as in-line splicing on high power cables is not allowed.

Terminate the braided shield at the motor by using a clamp that provides a 360° bond to the motor body. R-clamp the braid to the rear end bell of the motor housing; this not only provides a good high frequency bond, but strain relief as well.

At the drive end of the motor cable, fit a ferrite absorber over the cable before wiring to the motor connector. Locate the absorber as close as possible to the connector using heat-shrink sleeving. Expose a short length of braiding and anchor to the panel with an R-clamp. The motor cable should be kept away from I/O cables carrying control signals.

Index

Symbols

25-pin D-connector 19
3rd harmonic 23
4-lead motor wiring 44
6-lead motor wiring 44
8-lead motor wiring 45
800-358-9070 Compumotor application support 41

A

AC power connection 14, 28
AC power connector 6
active damping 33
 configuration procedure 34
ambient temperature limits 24
anti-resonance 32
 disable 16, 41
 gain 16
 phase setting 16
application support 41
automatic standby 16
automatic test 13, 41

B

balance 22
bipolar current rating 47
block diagram
 anti-resonance & active damping 32
 system 2
boot (for motor connector) 6

C

CE ii, 50
clearance requirements 25
clockwise input 20
clockwise/counterclockwise
 definition 15
 indexer 16
connector
 AC power 14, 28
 indexer 19
 motor 11, 12
counterclockwise – definition 15
counterclockwise input 20
couplers 27
current
 bipolar rating 47
 unipolar rating 47
current selection 15
 non-Compumotor motors 47
 O and R motors at 120VAC 63
 R motors at 240VAC 14
current waveform 15, 23
current-loop gain 16

D

D-connector 19
damping 31
DC supply filtering 54
diagnostic LEDs 40

dimensions
 drive 24
 motor
 O and R motors at 120VAC 61
 R motors at 240VAC 9
DIP switch location 13
DIP switch settings
 non-Compumotor motors 47
 O and R motors at 120VAC 63
 R motors at 240VAC 15
direction input 20
disable - anti-resonance 16
drive dimensions 24
drive resolution 15
drive/motor matching 22

E

earth 50
Electromagnetic Compatibility Directive ii, 53
electronic viscosity 33
 configuration procedure 36
EMC ii, 53
 motors with non-removable cables 65
EMC cable connections 54
EMC installation instructions 53
extending motor cables 26, 64

F

fan cooling 24
fault output 21
filtering DC supply 54

G

gain
 anti-resonance 16
 current loop 16
GRA (Goods Returned Authorization) number 42
graphic symbols 52
grounding motor case 11

H

harmonic, waveform 23
humidity 24

I

I/O, D-connector 19
indexer connector 19
inductance
 DIP switch setting 18
 large-signal 18
 small-signal 18
inertia, and active damping 34
inertia, DIP switch setting 17
information label 37
input
 clockwise/counterclockwise 20
 direction 20
 reset 21
 shutdown 20
 step 19
input filters 54

- installation
 - LVD & EMC 50
 - overview 6
 - test 29
- installation category 50
- interlock terminals 10

L

- label 37
- large-signal inductance 18
- LED functions 40
- losses (power) 28, 65
- Low Voltage Directive (LVD) ii, 50
- LVD ii, 50
- LVD installation 50

M

- magnetic label 37
- matching, drive/motor 22
- motor
 - cable wiring 54
 - connector 6, 11, 12
 - current selection
 - non-Compumotor motors 47
 - O and R motors at 120VAC 63
 - R motors at 240VAC 15
 - dimensions
 - O and R motors at 120VAC 61
 - R motors at 240VAC 9
 - EMC connections 54
 - extending cables 26
 - grounding 11
 - inductance 18
 - mounting 25
 - parallel wiring 12
 - selection 8
 - series wiring 11
 - specifications
 - O and R motors at 120VAC 61
 - R motors at 240VAC 9
 - speed/torque curves 8
 - wiring cable 54
- motor/drive matching 22
- mounting
 - drive 24
 - motor 25

N

- non-Compumotor motors 44
- non-removable motor cables
 - and EMC 65

O

- offset, phase 22
- output, fault 21
- overtemperature 24, 40

P

- panel layout 25
- parallel motor wiring 12
- peak power ratings 28, 65
- phase - anti-resonance setting 16
- phase balance 22
- phase offset 22
- pinout, D-connector 19
- pollution degree 50
- power connection 28
- power connector 6

- power ratings 28, 65
- precautions 6
- product return 42
- protective conductor terminal 51
- protective earth 51

Q

- quick test 13

R

- R-clamp installation 56
- regeneration 41
- reset input 21
- resolution 15
- resonance 30
- resonant speeds 22, 64
- return procedure 42
- ringing 30
- RMA 42
- rotary switches 34

S

- series motor wiring 11
- ship kit 6
- short circuit protection 41
- shutdown input 20
- small-signal inductance 18
- specifications
 - O and R motors at 120VAC 61
 - R motors at 240VAC 9
- speed/torque curves 8, 60
- standby, automatic 16
- static torque 18
- step & direction 16
- step input 19
- step-down transformer 28
- switch (DIP)
 - location 13
 - settings 15, 63
- symbols 52
- system inertia 17
- system test 29

T

- technical support 41
- temperature limits 24
- test
 - automatic test 13, 41
 - installation test 29
- third harmonic 23
- toll-free number 41
- torque, static 18
- torque/speed curves 8, 60
- transformer 28
- troubleshooting 40
- tuning - see matching 22

U

- unipolar rating 47

V

- volt-amp rating 28, 65

W

- waveform 15, 23
- wiring AC connector 14
- wiring precautions 11

DIP Switch Settings for R Motors* (for full DIP Switch Table see page 15)

ZETA4-240 Drive Compumotor



Damping in the ZETA4-240 Drive

- Anti-Resonance** Works at speeds > 3 rps. DIP SW2-#2 must be off. pg 32
- Electronic Viscosity** Works from zero to 3 rps. Adjust with rotary switch. Disabled if switch is at 0. pg 33
- Active Damping** Works at speeds > 3 rps. Adjust with 7 DIPs and 16-position rotary switch. Disabled if rot. sw. at 0. Switch setting based on total system inertia. pg 33

SERIES		PARALLEL	
	RS31C(S)		RS31C(P)
	RS32C(S)		RS32C(P)
	RS33C(S)		RS33C(P)
	RS42C(S)		RS42C(P)
	RE42C(S)		RE42C(P)
	RS43C(S)		RS43C(P)

*Configured for 25,000 steps/rev, -4% 3rd harmonic, S&D indexer, auto standby off, anti-res. enabled, anti-res. phase resonant frequency < 200 Hz, anti-res gain = standard, current-loop gain = standard, system inertia less than 20 kg-cm². (S) = Series motor wiring; (P) = Parallel motor wiring

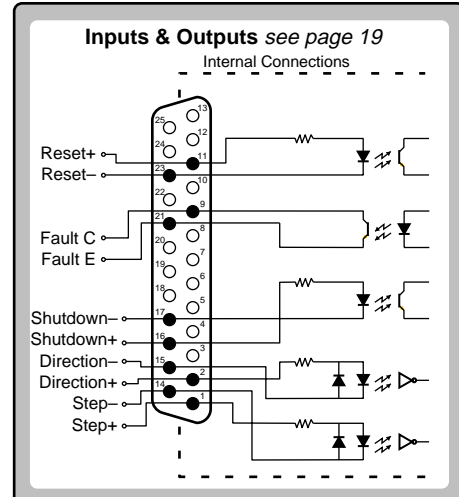
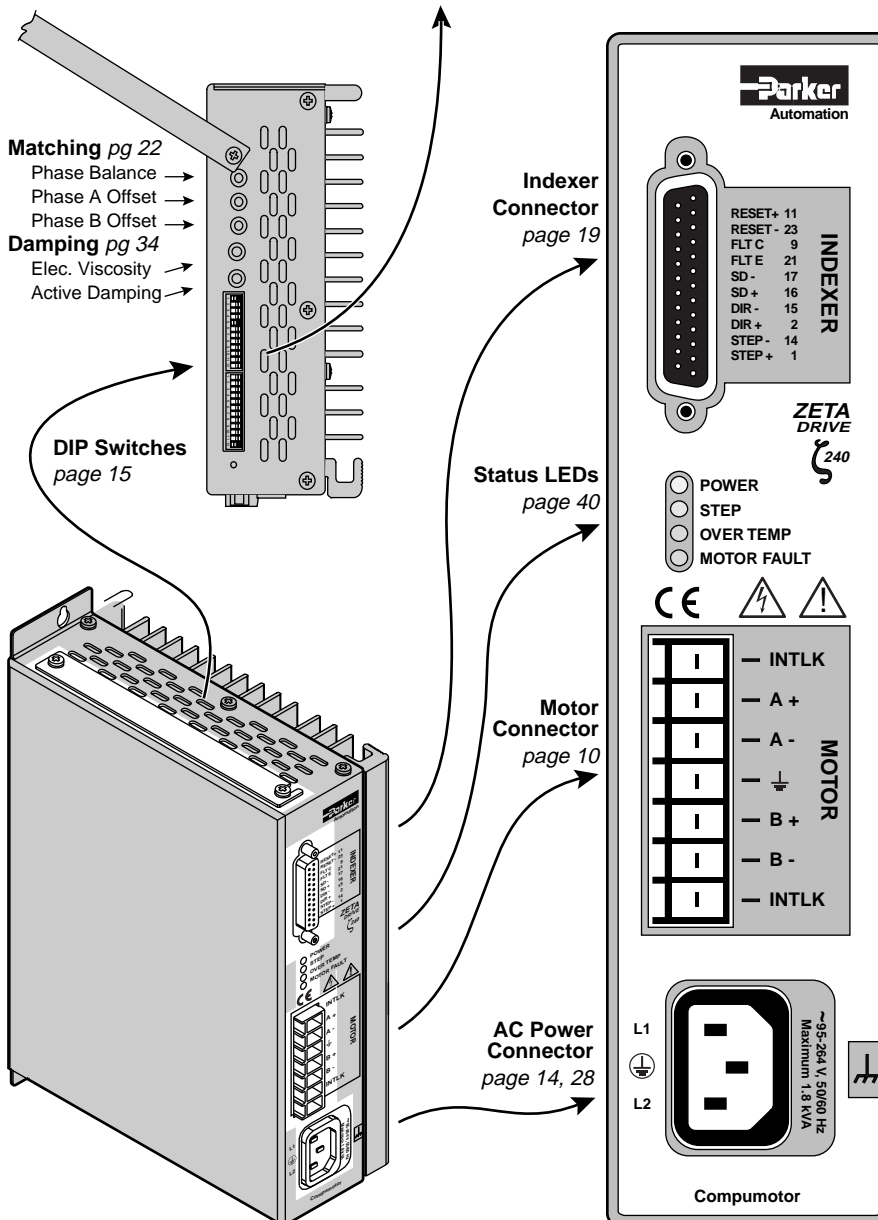

Status LEDs see page 40

POWER Green when power is on
STEP Green when drive receives step
 Flashes Red/Green in auto test
OVER TEMP Red indicates over temp fault
MOTOR FAULT Red when drive detects short circuit in motor or motor cable; Red if interlock is open

Motor Wiring

R Motors at 240VAC see page 12
 O and R Motors at 120VAC see page 60
 Non-Compumotor Motors see page 44

