

Compumotor

C Series Drive User Guide

Compumotor Division
Parker Hannifin Corporation
p/n 88-005712-03 B



User Guide Change Summary

The following is a summary of the primary changes to this user guide since the last version was released. This user guide, version 88-005712-03B, supersedes version 88-005712-03A.

When a user guide is updated, the new or changed text is differentiated with a change bar in the right margin (this paragraph is an example). If an entire chapter is changed, the change bar is located to the right of the chapter title.

The entire user guide has been changed according to the new Compumotor user guide styles and illustration standards. Also, the chapters have been renumbered and reorganized.

Chapter 1. Introduction

Changes to Chapter 1 are summarized as follows:

- New voltage requirements (C and CT Drives)
- Updated product features
- New Theory of Operation section

Chapter 2. Getting Started

Changes to Chapter 2 are summarized as follows:

- New and updated system connection procedures
- New factory default jumper settings
- Additional jumper-selectable motor resolutions
- Ship kit changes

Chapter 3. Installation

Changes to Chapter 3 are summarized as follows:

- All optional jumper settings moved to Chapter 2
- New drive mounting guidelines
- Added guidelines for coupling the load to the motor

Chapter 4. Hardware Reference

Changes to Chapter 4 are summarized as follows:

- Added default jumper settings
- Added C Series and CT Series motor specifications
- Added circuit drawing for step, direction, and shutdown
- New System pinouts and connectors illustration
- Updated Compumotor motor cable color codes
- Updated drive dimensional drawings (refer to Catalog for motor dimensional drawings)
- Removed torque/speed curves (refer to catalog)
- Removed optional jumper settings (refer to Chapter 2)
- System specifications updated to show new input power requirements and available resolutions

Chapter 5. Maintenance & Troubleshooting

Changes to Chapter 5 are summarized as follows:

- New list of suggested spare parts
- New drive and motor maintenance information
- New troubleshooting methods
- New procedures for returning the system to affect repairs or upgrades

TABLE OF CONTENTS

CONTENTS	i
List of Figures.....	ii
List of Tables.....	ii
How To Use This User Guide.....	iii
Assumptions.....	iii
Contents of This User Guide.....	iii
Installation Process Overview.....	iv
Installation Recommendations.....	iv
Developing Your Application.....	v
Conventions.....	v
Warnings & Cautions.....	v
Change Bars.....	v
Related Publications.....	v
Chapter 1. INTRODUCTION	1
Product Description.....	1
Motor Compatibility.....	1
Product Features.....	2
Theory of Operation.....	2
Chapter 2. GETTING STARTED	3
What You Should Have.....	3
Setting Drive Functions.....	4
Motor Current.....	4
Auto Run.....	6
Auto Standby.....	7
Motor Resolution.....	7
Motor Waveform.....	7
System Connections.....	8
Motor Connections.....	8
Indexer Connections.....	9
Power Supply Connections.....	9
Powering Up the C Series Drive.....	10
Functional Test.....	10
Chapter 3. INSTALLATION	11
Adjusting Drive Functions.....	11
Drive Mounting.....	11
System Connections.....	12
Wiring Guidelines.....	12
Verifying Proper Installation.....	13
System Functional Test.....	13
Coupling the Load.....	13
Chapter 4. HARDWARE REFERENCE	15
Chapter Objectives.....	15
System Specifications.....	15
C Series Drive Specifications.....	15
C Series Motor Specifications.....	16
CT Series Motor Specifications.....	16
Default Drive Settings.....	17
Connector Summary and Pinouts.....	17
Motor Cable Color Codes.....	17
I/O Descriptions.....	18
I/O Circuit Diagram.....	18
Dimensional Drawing.....	19

Chapter 5. MAINTENANCE & TROUBLESHOOTING..... 21

Chapter Objectives.....21

Maintenance.....21

 Spare Parts Table.....21

 Motor Maintenance.....21

 Drive Maintenance.....21

Troubleshooting.....22

Reducing Electrical Noise.....24

Returning The System.....25

List of Figures

Figure 1-1. Simplified C Drive System Functional Block Diagram.....2

Figure 2-1. Location of Jumpers4

Figure 2-2. C Drive System Connections.....8

Figure 2-3. Powering Multiple Drives.....9

Figure 3-1. Drive Mounting.....11

Figure 4-1. C Series Drive Pinouts and Connectors.....17

Figure 4-2. Step, Direction, and Shutdown Circuits.....18

Figure 4-3. C Series Drive Dimensions19

List of Tables

Table 2-1. C Drive Ship Kit.....3

Table 2-2. Compumotor-Supplied Motors.....3

Table 2-3. Jumper Functions.....4

Table 2-4. Motor Current Settings for Compumotor-Supplied Motors.....5

Table 2-5. Full Range Current Settings (Standard C Drive).....5

Table 2-6. Full Range Current Settings (CT Drive).....6

Table 2-7. Motor Resolution Settings.....7

Table 2-8. Motor Waveform Settings.....7

Table 2-9. Compumotor Motor Cable Color Codes.....8

Table 4-1. C Series Drive Specifications.....15

Table 4-2. C Series Motor Specifications.....16

Table 4-3. CT Series Motor Specifications16

Table 4-4. Default and Recommended Jumper Settings.....17

Table 4-5. Compumotor Motor Cable Color Codes.....17

Table 4-6. Input Relationships.....18

Table 5-1. Recommended Spare Parts for the C Series Drive System.....21

How To Use This User Guide

This user guide is designed to help you install, develop, and maintain your system. Each chapter begins with a list of specific objectives that should be met after you have read the chapter. This section is intended to help you find and use the information in this manual.

Assumptions

This user guide assumes that you have the skills or fundamental understanding of the following information.

- Basic electronics concepts (voltage, switches, current, resistors, etc.)
- Basic motion control concepts (torque, velocity, distance, etc.)

With this level of understanding, you can effectively use this user guide to install, develop, and maintain your system.

Contents of This User Guide

This user guide contains the following information:

Chapter 1: Introduction

This chapter provides a description of the product and a brief account of its specific features.

Chapter 2: Getting Started

This chapter contains a detailed list of items you should have received with your C Drive system shipment. It will help you become familiar with the system and ensure that each component functions properly. In this chapter, you will perform a preliminary configuration of the system.

Chapter 3: Installation

This chapter provides instructions for you to properly mount the system and make all electrical connections. Upon completion of this chapter, your system should be completely configured, installed, and ready to perform basic operations.

Chapter 4: Hardware Reference

This chapter contains information on system specifications and dimensions. Use this chapter as a quick-reference tool for jumper default settings and I/O connections.

Chapter 5: Maintenance & Troubleshooting

This chapter describes Compumotor's recommended system maintenance procedures. It also provides methods for isolating and resolving hardware problems.

Installation Process Overview

To ensure trouble-free operation, you should pay special attention to the following:

- The environment in which the C Drive system will operate
- The system layout and mounting
- The wiring and grounding practices used

These recommendations are intended to help you easily and safely integrate the C Drive system into your manufacturing facility. Industrial environments often contain conditions that may adversely affect solid state equipment. Electrical noise or atmospheric contamination may also affect the C Drive system.

Installation Recommendations

Before you attempt to install this product, you should complete the following steps:

- STEP 1 Review this entire manual. Become familiar with the manual's contents so that you can quickly find the information you need.
- STEP 2 Develop a basic understanding of all system components, their functions, and interrelationships.
- STEP 3 Complete the basic system configuration and wiring instructions provided in Chapter 2, Getting Started. *Note that this is a preliminary configuration, not a permanent installation, usually performed in a bench-top environment.*
- STEP 4 Perform as many basic moves and functions as you can with the preliminary configuration. You can perform this task only if you have reviewed the entire manual. You should try to simulate the task(s) that you expect to perform when you permanently install your system. *However, do not attach a load at this time.* This will give you a realistic preview of what to expect from the complete configuration.
- STEP 5 After you have tested all of the system's functions and used or become familiar with all of the system's features, carefully read Chapter 3, Installation.
- STEP 6 After you have read Chapter 3 and clearly understand what must be done to properly install the system, you should begin the installation process. **Proceed in a linear manner;** do not deviate from the sequence or installation methods provided.
- STEP 7 Before you begin to customize your system, check all of the system functions and features to ensure that you have completed the installation process correctly.

The successful completion of these steps will prevent subsequent performance problems and allow you to isolate and resolve any potential system difficulties before they affect your system's operation.

Developing Your Application

Before you attempt to develop and implement your application, you should consider the following:

- Recognize and clarify the requirements of your application.
- Assess your resources and limitations. This will help you find the most efficient and effective means of developing and implementing your application.
- Follow the guidelines and instructions outlined in this user guide. **Do not skip any steps or procedures.** Proper installation and implementation can be ensured only if all procedures are completed in the proper sequence.

Conventions

To help you understand and use this user guide effectively, the conventions used throughout this user guide are explained in this section.

Warnings & Cautions

Warning and caution notes alert you to possible dangers that may occur if you do not follow instructions correctly. Situations that may cause bodily injury are presented as warnings. Situations that may cause system damage are presented as cautions. These notes will appear in bold face and the word warning or caution will be centered and in all capital letters. Refer to the examples shown below.

WARNING

Do not touch the motor immediately after it has been in use for an extended period of time. The unit will be hot.

CAUTION

System damage will occur if you power up the system improperly.

Change Bars

When a new user guide version is produced, the new or changed text is differentiated with a change bar in the right margin (this paragraph is an example). If the entire chapter is changed, the change bar is located to the right of the chapter title.

Related Publications

The following publications may be helpful resources:

- *Parker Compumotor Programmable Motion Control Catalog*
- Schram, Peter (editor). *The National Electric Code Handbook (Third Edition)*. Quincy, MA: National Fire Protection Association

Chapter 1. INTRODUCTION

Chapter Objective

The objective of this chapter is to provide you with information to understand the product's basic functions and features.

Product Description

C Series Drives are compact microstepping drives designed to control standard 1.8°, two-phase hybrid stepper motors. These drives, the standard C Drive and the low-powered CT Drive, provide pulse-width modulated power at a switching frequency of approximately 20 kHz.

The standard C Drive provides up to 5A of current per phase. Torques from 10 to 800 oz-in can be obtained. You can use 6 and 8 leaded motors if the motor's inductance does not drop below 2.5 mH per 30V of motor voltage (measured center-to-end).

The CT Drive is modified for lower output current (0 to 1A) and for +12 to +24V operation. The maximum motor supply voltage for the CT Drive is 24V.

Compumotor provides two-phase, hybrid (permanent magnet) motors in NEMA frame sizes from 10 through 42. The standard C Drive operates motor sizes 23 through 42. The CT Drive operates *miniature* motor sizes 10 through 17.

C Series Drives require two external DC voltages. C and CT Logic power requires 9 to 24V (regulated). C Drive motor power requires 12 to 90V (unregulated), and CT Drive motor power requires 12 to 24V. The Compumotor DC3 power supply provides both of these voltages.

Motor Compatibility

C Series Drives will operate most standard 6 or 8 lead, 1.8°, two phase, hybrid stepping motors. Motor phase current is jumper selectable. This refers to the center tap-to-end current. Most motor manufacturers specify current in this manner for 6 or 8 lead motors.

Stepper motors with a variety of phase current and inductance ratings are available. The correct motor winding depends on the individual application. Motors with lower inductance windings offer better high-speed performance at increased current. These motors generally operate from lower voltage power supplies than high-inductance motors, but will produce more heat if operated at high voltages and speeds. High inductance motors provide high torques at low currents, but have limited speed. ***C Series Drives require a minimum phase inductance (center to end) of 2.5 mH.***

Product Features

Features of the C Series Drives are as follows:

- Factory default resolution of 200 steps per revolution, with optional jumper-selectable settings of 25,000, 20,000, 18,000, 10,000, 5,000, 2,000, and 400 steps/rev
- High-speed operation (to 3,000 RPM with low-inductance motors)
- Compact (4.1" by 6.5" footprint) enclosure with integral heatsink
- Protected against brownouts, over-temperature, and short circuits (phase-to-phase, not phase-to-ground), protection
- Optically isolated step, direction, and shutdown inputs
- Advanced MOSFET design with integral microprocessor
- User-selectable motor current (up to 5A per phase for standard drive and up to 1A for CT version)
- Requires external power supply (more than one unit can be run from a single supply)
- 5-pin and 4-pin removable screw terminal connectors for motor and power connections
- A 25-pin D connector for controller inputs (compatible with all Compumotor indexers)
- Unipolar drive technique provides excellent high-speed torque
- Automatic Standby feature reduces motor current when the motor is not moving (jumper-selectable)
- Controls a wide range of standard 1.8° stepper motors
- Jumper-selectable motor current waveforms (to improve smooth motor operation)

Theory of Operation

An external indexer sends step pulses to the C Drive via the 25-pin D connector. These step pulses, are coupled with a direction signal to control motor velocity, acceleration, direction, and position. The C Drive converts the step pulses to varied motor currents to control the stepper motor's rotation and angular position. The motor converts electrical pulses into discrete mechanical motion (shaft rotation). Figure 1-1 is a simplified system functional block diagram.

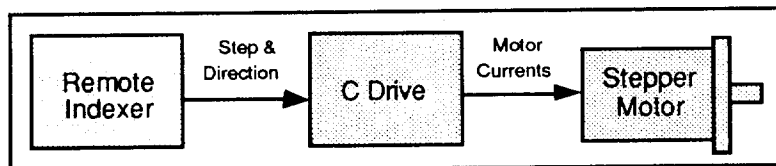

Figure 1-1. Simplified C Drive System Functional Block Diagram

For a detailed description of stepper motor construction and operation, refer to the *Compumotor Programmable Motion Control Catalog*.

Chapter 2. GETTING STARTED

Chapter Objectives

The information in this chapter will enable you to do the following:

- Verify that each component of your system has been delivered safely
- Become familiar with system components and their interrelationships
- Establish the basic system configuration
- Ensure that each component functions properly

What You Should Have

Inspect your C Drive shipment upon receipt for damage to its shipping container. Report any damage to the shipping company immediately. Parker Compumotor cannot be held responsible for damage incurred in shipment. The items listed in Table 2-1 should be present and in good condition. *The only way to tell if you have a C or CT model is to check the serial plate located on the back of the drive.*

Description	Part Number
Possible Drives: C Drive CT Drive	C-DRIVE CT-DRIVE
Pkg. of 16 Jumpers	43-002435-01
Motor (optional)	(see Table 2-2)
DC3 Power Supply (optional)	DC3
C Drive User Guide	88-005712-03

Table 2-1. C Drive Ship Kit

Description	Part Number
C57-51 Motor	057051-2-6-010-010
C57-83 Motor	057083-2-6-016-010
C57-102 Motor	057102-2-6-017-010
C83-62 Motor	083062-2-6-020-010
C83-93 Motor	083093-2-6-025-010
C83-135 Motor	083135-2-6-035-010
C106-120 Motor	106120-1-6-045-100
C106-178 Motor	106178-2-6-050-100
CT25-30 Motor*	025030-1-6-004-010
CT27-38 Motor*	027038-1-6-003-010
CT32-39 Motor*	032039-1-6-010-010

* Used only with the CT Drive

Table 2-2. Compumotor-Supplied Motors

Setting Drive Functions

Drive functions are set with jumpers JU1 through JU12, located behind the indexer connector (J2) (see Figure 2-1). The drives are shipped with all jumpers removed; therefore, before operating the drive, you must configure these jumpers for your application. You will find additional jumpers in the ship kit. Table 2-3 shows the function of each jumper.

Jumper	Function
JU1 through JU5	Current
JU6	Auto Run
JU7	Auto Standby
JU8 through JU10	Motor Resolution
JU11 & JU12	Waveform

Table 2-3. Jumper Functions

The ON/OFF jumper convention used in the following tables is described below.

- **ON** = Jumper is installed over the two pins
- **OFF** = Jumper is not installed

WARNING

Always be sure power is removed before changing the drive jumpers.

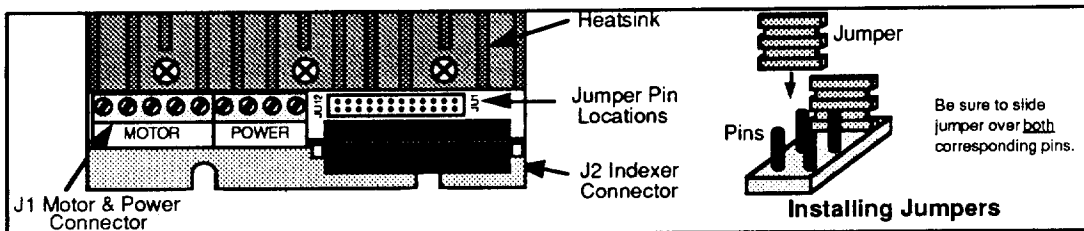

Figure 2-1. Location of Jumpers

Motor Current (JU1 - JU5)

Pins JU1 - JU5 control motor current. If you are using motors supplied by Compumotor, refer to Table 2-4 for the appropriate current settings.

If you are using a non-Compumotor motor, refer to Table 2-5 for optional current settings on the standard C Drive and Table 2-6 for optional current settings on the CT version.

CAUTION

Incorrect current settings can damage the motor and the drive.

The recommended motor current settings will provide smooth operation. If enhanced smoothness is required, reducing the current 10-15% will improve low-speed smoothness at the expense of torque. Current can be increased up to 9% if additional torque is needed. **However, increasing the current to the motor is not recommended because it can overheat the motor.**

Motor Model	Current (amps/phase)	JU1	JU2	JU3	JU4	JU5
C57-51	0.94	OFF	OFF	ON	OFF	ON
C57-83	1.56	OFF	ON	OFF	OFF	ON
C57-102	1.72	OFF	ON	OFF	ON	OFF
C83-62	2.03	OFF	ON	ON	OFF	OFF
C83-93	2.50	OFF	ON	ON	ON	ON
C83-135	3.44	ON	OFF	ON	OFF	ON
C106-120	4.53	ON	ON	ON	OFF	OFF
C106-178	5.00	ON	ON	ON	ON	ON
CT25-30*	0.31	OFF	ON	OFF	OFF	ON
CT27-38*	0.41	OFF	ON	ON	OFF	OFF
CT32-39*	0.62	ON	OFF	OFF	ON	ON

* These settings are applicable only to the CT version.

Table 2-4. Motor Current Settings for Compumotor-Supplied Motors

Standard C Drive

Current	JU1	JU2	JU3	JU4	JU5
0.14*	OFF	OFF	OFF	OFF	OFF
0.31	OFF	OFF	OFF	OFF	ON
0.47	OFF	OFF	OFF	ON	OFF
0.62	OFF	OFF	OFF	ON	ON
0.78	OFF	OFF	ON	OFF	OFF
0.94	OFF	OFF	ON	OFF	ON
1.09	OFF	OFF	ON	ON	OFF
1.25	OFF	OFF	ON	ON	ON
1.41	OFF	ON	OFF	OFF	OFF
1.56	OFF	ON	OFF	OFF	ON
1.72	OFF	ON	OFF	ON	OFF
1.87	OFF	ON	OFF	ON	ON
2.03	OFF	ON	ON	OFF	OFF
2.19	OFF	ON	ON	OFF	ON
2.34	OFF	ON	ON	ON	OFF
2.50	OFF	ON	ON	ON	ON
2.66	ON	OFF	OFF	OFF	OFF
2.81	ON	OFF	OFF	OFF	ON
2.97	ON	OFF	OFF	ON	OFF
3.12	ON	OFF	OFF	ON	ON
3.28	ON	OFF	ON	OFF	OFF
3.44	ON	OFF	ON	OFF	ON
3.59	ON	OFF	ON	ON	OFF
3.75	ON	OFF	ON	ON	ON
3.91	ON	ON	OFF	OFF	OFF
4.06	ON	ON	OFF	OFF	ON
4.22	ON	ON	OFF	ON	OFF
4.37	ON	ON	OFF	ON	ON
4.53	ON	ON	ON	OFF	OFF
4.68	ON	ON	ON	OFF	ON
4.84	ON	ON	ON	ON	OFF
5.00	ON	ON	ON	ON	ON

* Factory Default Setting

Table 2-5. Full Range Current Settings (Standard C Drive)

CT Drive

Current	JU1	JU2	JU3	JU4	JU5
0.03*	OFF	OFF	OFF	OFF	OFF
0.06	OFF	OFF	OFF	OFF	ON
0.09	OFF	OFF	OFF	ON	OFF
0.12	OFF	OFF	OFF	ON	ON
0.16	OFF	OFF	ON	OFF	OFF
0.19	OFF	OFF	ON	OFF	ON
0.22	OFF	OFF	ON	ON	OFF
0.25	OFF	OFF	ON	ON	ON
0.28	OFF	ON	OFF	OFF	OFF
0.31	OFF	ON	OFF	OFF	ON
0.34	OFF	ON	OFF	ON	OFF
0.37	OFF	ON	OFF	ON	ON
0.41	OFF	ON	ON	OFF	OFF
0.44	OFF	ON	ON	OFF	ON
0.47	OFF	ON	ON	ON	OFF
0.50	OFF	ON	ON	ON	ON
0.53	ON	OFF	OFF	OFF	OFF
0.56	ON	OFF	OFF	OFF	ON
0.59	ON	OFF	OFF	ON	OFF
0.62	ON	OFF	OFF	ON	ON
0.66	ON	OFF	ON	OFF	OFF
0.69	ON	OFF	ON	OFF	ON
0.72	ON	OFF	ON	ON	OFF
0.75	ON	OFF	ON	ON	ON
0.78	ON	ON	OFF	OFF	OFF
0.81	ON	ON	OFF	OFF	ON
0.84	ON	ON	OFF	ON	OFF
0.87	ON	ON	OFF	ON	ON
0.91	ON	ON	ON	OFF	OFF
0.94	ON	ON	ON	OFF	ON
0.97	ON	ON	ON	ON	OFF
1.00	ON	ON	ON	ON	ON

* Factory Default Setting

Table 2-6. Full Range Current Settings (CT Drive)

**Auto Run
(JU6)**

ON = Disables Auto Run mode

OFF = Enables Auto Run mode (factory default setting)

For normal operation, this jumper (JU6) should be installed (disables Auto Run). Leave this jumper off (enables Auto Run) to accommodate the functional test performed later in this chapter. During the functional test, when you apply power to the drive, the motor rotates continuously at approximately 1 rps until you shut down the drive. **Do not apply power until you are instructed to do so.** *The status of JU6 is checked only at power up.*

**Auto Standby
(JU7)**

ON = Disables Auto Standby mode
OFF = Enables Auto Standby mode (factory default setting)

Install jumper JU7 (disable Auto Standby). This is recommended for normal operation. If you initiate the Auto Standby function (by removing the jumper and reapplying power), the C Drive automatically reduces the current to the motor by 50% if no step pulses are received for 1 second. Full current is restored instantaneously upon receipt of the first step pulse. **Do not apply power until you are instructed to do so.** The status of JU7 is checked only at power up.

**Motor Resolution
(JU8 - JU10)**

Table 2-7 contains the motor resolution values associated with the specific jumper settings. The resolution settings assume the use of a 1.8° (200 step/rev) hybrid permanent magnet stepper motor. *The status of jumpers JU8 - JU10 are checked only at power up.*

To accommodate the functional test in this chapter, install jumpers JU8 - JU10 (sets the resolution at 25,000 steps/rev). **However, during normal operation, the indexer resolution must match the drive resolution in order to achieve the desired acceleration and velocity,**

Resolution (steps/rev)	JU8	JU9	JU10
25,000	ON	ON	ON
20,000	OFF	ON	ON
18,000	ON	OFF	ON
10,000	OFF	OFF	ON
5,000	ON	ON	OFF
2,000	OFF	ON	OFF
400	ON	OFF	OFF
200*	OFF	OFF	OFF

* Factory Default Setting

Table 2-7. Motor Resolution Settings

**Motor Waveform
(JU11 & JU12)**

The following are the three motor waveforms selectable with jumpers JU11 and JU12:

- +4% 3rd harmonic
- -4% 3rd harmonic
- Pure sine wave

These waveforms help you overcome resonance problems (esp. at low speeds) and allow the motor to run smoothly. Use Table 2-8 to select the desired waveform. *The status of jumpers JU11 and JU12 are checked only at power up.*

Waveform Shape	JU11	JU12
Pure Sine*	OFF	OFF
+4% 3rd	ON	OFF
-4% 3rd	OFF	ON
Pure Sine	ON	ON

* Factory Default Setting

Table 2-8. Motor Waveform Settings

System Connections

The C Drive is protected against short circuits (phase-to-phase, but not phase-to-ground) and over-temperature. Compumotor does not recommend that you test these protection features or operate your system in such a way as to induce short circuiting or over-temperature.

CAUTION

Never disconnect the motor with power on. It will damage the contacts of the motor connector.

Figure 2-2 illustrates the system connections to the C Drive connectors. System specifications are provided in Chapter 4, Hardware Reference.

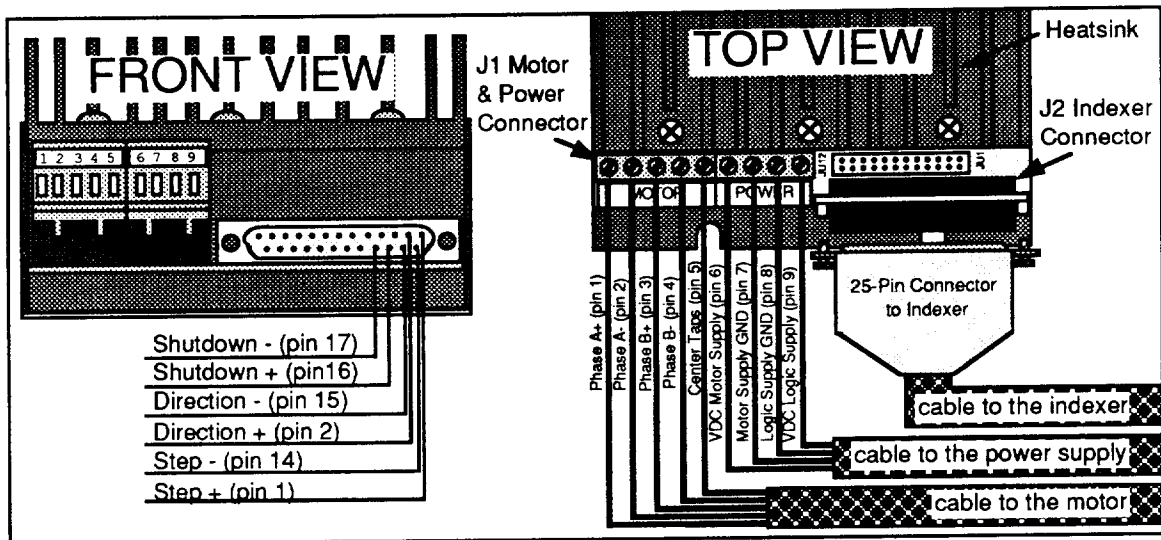

Figure 2-2. C Drive System Connections

Motor Connections

If you are using a Compumotor motor, connect the motor leads to connector J1 pins 1 through 5 (see Figure 2-2). Refer to Table 2-9 for Compumotor motor cable color codes. **Incorrect motor connections can cause extensive damage to the drive and the motor.**

Pin #	Description	CT25-30 and CT32-39	C57 & C83 Series and CT27-38	C106 Series
1	Phase A+	Red	Red	Red
2	Phase A-	Yellow	Red/White	Black
3	Phase B+	Green	Green	Yellow
4	Phase B-	Blue	Green/White	Green
5	Center Taps*	Brown, Black, White & Violet	White & Black	Orange & Brown

* Center tap wires for **both** phases should be connected to Pin #5.

Table 2-9. Compumotor Motor Cable Color Codes

If you purchased a motor from another vendor, refer to the manufacturer's wiring instructions to determine which motor wires correspond to Phase A and Phase B. After you determine the motor's wiring configuration, connect the motor leads to the C Drive as illustrated in Figure 2-2.

Indexer Connections

Refer to Figure 2-2 for proper connections to the Indexer connector (J2) on the C Drive. Figure 2-2 also shows the pinouts for the Indexer connector on the C Drive.

The C Drive steps the motor one microstep for every pulse received on its step input. The state of the direction input at the time the first step pulse is received determines the rotational direction of the motor shaft. The direction input must be stable for at least 20 μ s before receiving the first step pulse.

Refer to Chapter 4, Hardware Reference, for system specifications and circuit diagrams for step, direction, and shutdown.

CAUTION

When you enable the shutdown input, all current is removed from the motor windings, allowing the shaft to rotate freely (*freewheel*).

Power Supply Connections

Connect the power supply to the C Drive as illustrated in Figure 2-2. The motor supply (J1 pin 6) requires 12 to 90VDC input. The logic supply (J1 pin 9) requires 9 to 24VDC input.

Close attention is required when wiring the DC3 to the C Drive. Pinouts of the DC3 are indicated on the rear of the power supply unit. Refer to the *DC3 Operator's Manual* for power supply specifications and set-up instructions.

CAUTION

Make sure that AC power is removed from the power supply before connecting it to the C Drive.

If you intend to power more than one C Drive from one power supply, you must add an electrolytic capacitor across the logic supply input terminals of each drive. As illustrated in Figure 2-3, connect the power supply separately to each drive. Do not daisy-chain the power between the drives. An electrolytic capacitor of 330 μ f at 35VDC should be sufficient. *Be sure to connect the capacitor's negative lead to J1 Pin 8 (Logic Supply Ground) and connect the positive (+) lead to Pin 9 (Logic Supply).*

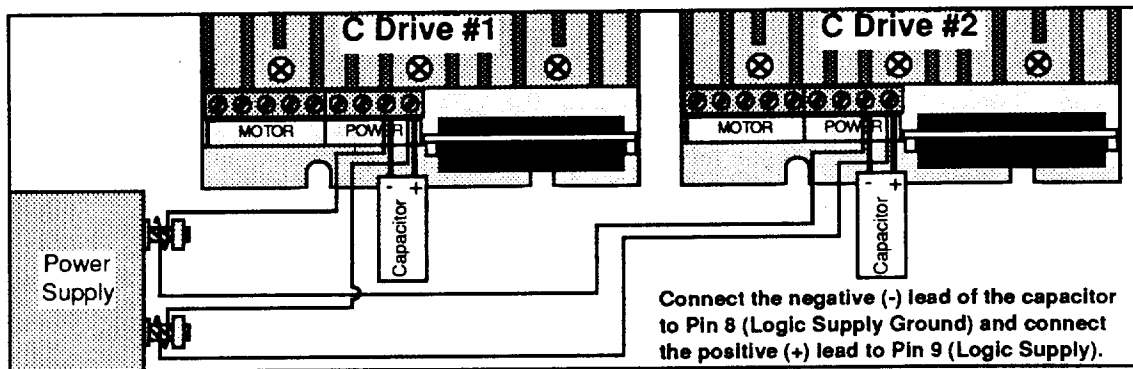

Figure 2-3. Powering Multiple Drives

Powering Up the C Series Drive

Before you power-up the C Drive, verify that the power supply and motor cables are properly connected. If everything is OK, the drive will be enabled (evident by *holding torque* on the motor) when you apply power. If the motor does not have holding torque, remove power to the system and refer to Chapter 5, Maintenance & Troubleshooting.

Drive LED

The C Drive's LED is located on the back panel opposite the connector-side of the drive. It indicates one of the three conditions described below. *NOTE: The following conditions assume that the Bias Supply is properly applied to the drive.*

- The LED will be off when the C Drive is functioning properly and no step pulses are being sent to the drive.
- The LED will turn green when the C Drive is functioning properly and the drive is receiving step pulses.
- The LED will turn red when the amplifier is off. The amplifier can be turned off by a short circuit, an over-temperature condition, or by activating the shutdown input. *The red LED condition is a priority condition that overrides all other conditions.*

CAUTION

If the drive experiences a short circuit, a power dump overload, or an over-temperature condition, the fault is latched. The power to the drive must be cycled to unlatch the fault condition. The source of the fault must be corrected before power is reapplied to the unit.

Functional Test

Use the following procedures to test the functionality of the C Series Drive system and to verify proper system connections.

STEP 1

Set up the indexer to run in accordance with the installation procedures outlined in the indexer user guide. Make sure the indexer resolution (steps/rev) matches the drive resolution setting (see Table 2-7 for drive resolution settings).

STEP 2

Apply power to the drive and set the indexer to perform a move with the following parameters:

- Step Pulse Width = Minimum of 500 ns
- Distance = 25,000 steps (1 rev @ 25,000 steps/rev)
- Acceleration = 5 rps²
- Velocity = 4 revolutions per second (rps) - (100kHz with default resolution of 25,000 steps/rev)

Executing this move should cause the motor to make a 25,000-step move (one revolution if the resolution is 25,000 steps/rev).

If the motor does not move, refer to Chapter 5, Maintenance & Troubleshooting.

STEP 3

After you successfully complete steps 1 and 2, power down and install jumper JU6 to disable Auto Run for normal operation.

Chapter 3. INSTALLATION

Chapter Objectives

The information in this chapter will enable you to do the following:

- Mount all system components properly
- Connect all electrical system inputs and outputs properly
- Ensure that the complete system is installed properly

NOTE: You must complete all steps in Chapter 2, Getting Started, before proceeding with the steps in this chapter.

Adjusting Drive Functions

Drive functions are set with the 12 jumpers located behind the indexer connector (J2). These jumpers are used to select motor current, auto run, auto standby, motor resolution, and waveform. If you need to adjust these settings, refer to the Setting Drive Functions section in Chapter 2.

Drive Mounting

Consider atmospheric contamination and excess heat before you install and operate your C Series Drive system.

C Series Drives are designed to be convection cooled. The drive should be mounted with the heatsink oriented vertically and in an area that will allow sufficient air to circulate over the heatsink (refer to Figure 3-1). The drive will automatically shut down if the maximum internal air temperature of 158°F (70°C) is exceeded. This will normally not be a problem when the drive is powering 23 and 34 frame size motors. If the unit is driving larger motors or is enclosed, you may need to provide fan cooling over the heatsink. Allow at least 3 inches horizontal clearance and 6 inches vertical clearance between drives.

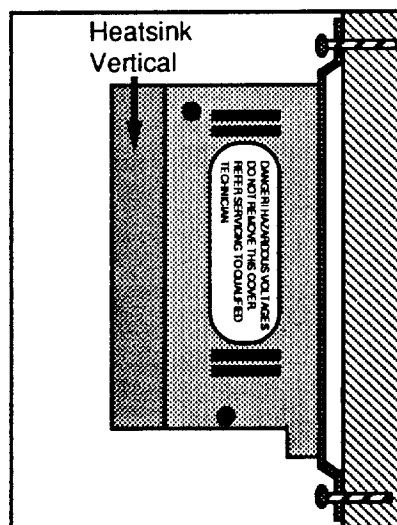

Figure 3-1. Drive Mounting

System Connections

Refer to Chapter 2, Getting Started, for instructions to connect the following system components:

- Motor
- Indexer
- Power Supply

System pinouts and specifications are provided in Chapter 4, Hardware Reference.

The C Drive is protected against short circuits (phase-to-phase only) and over-temperature. Compumotor does not recommend that you test these features or operate your system in such a way as to induce short circuiting or over-temperature situations.

Wiring Guidelines

Proper grounding of electrical equipment is essential to ensure the safety of personnel. You can reduce the effects of electrical noise due to electromagnetic interference (EMI) by grounding. All Compumotor equipment should be properly grounded. A good source of information on grounding requirements is the National Electrical Code published by the National Fire Protection Association of Boston, MA.

In general, all components and enclosures must be connected to earth ground through a grounding electrode conductor to provide a low-impedance path for ground fault or noise-induced currents. All earth ground connections must be continuous and permanent. Compumotor recommends a single-point grounding setup.

One commonly used method is to prepare components and mounting surfaces prior to installation so that good electrical contact is made between mounting surfaces of equipment and the enclosure. Remove the paint from equipment surfaces where the ground contact will be bolted to a panel and use star washers to ensure solid bare metal contact. Connect the case of the motor to earth ground.

Shielding

Motor leads should be shielded to reduce electro-magnetic interference (EMI). This shield must be returned to earth ground, **not DC ground**.

Power supply wires should also be shielded (separate from the motor leads). The pair of wires from the logic supply should be shielded and that shield should be connected to earth ground. The pair of wires from the motor supply should also be shielded (separate shield than the logic supply) and that shield connected to earth ground.

Grounding

The C Drive chassis should be connected to a reliable earth ground for safety reasons. There is a grounding screw/star washer combination on the side of the drive available for this purpose. This screw should be removed and a ring-tongue terminal or lug connected through a wire to earth ground should be placed under the screw and the screw should be re-inserted.

The logic supply and motor supply wires should be at least 18 gauge for most applications. The return, or ground wires, for each supply should be connected together only at the drive (this is done internal to the drive). This prevents motor current *spikes* from entering the unit's logic ground.

Verifying Proper Installation

This section provides procedures for verifying proper installation of the C Drive system.

System Functional Test

Return to Chapter 2, Getting Started and perform the system power-up and functional test procedures. This verifies power, motor, and indexer connections. Pay special attention to the LED.

For indexer functional tests, refer to the indexer user guide.

Coupling the Load

Special couplings that accommodate different types of misalignments are available. The following are the three types of misalignments; they can exist in any combination.

- Parallel Misalignment. The offset of two mating shaft center lines, although the center lines remain parallel to each other
- Angular Misalignment. When two shaft center lines intersect at an angle other than zero degrees
- End Float. A change in the relative distance between the ends of two shafts

Special couplings are used to accommodate the above misalignments and to transmit the desired torque. The coupling manufacturer should be consulted to ensure that the coupling is being used within its specified torque capacity and misalignment ranges.

Shaft couplings may be divided into three types: single-flex, double-flex, and rigid. Like a hinge, a single-flex coupling accepts angular misalignment only. A double-flex coupling accepts both angular and parallel misalignments. Both single-flex and double-flex, depending on their design, may or may not accept end-play. A rigid coupling cannot compensate for any misalignment.

CAUTION

Do not disassemble the motor or machine the motor shaft without consulting a Compumotor Applications Engineer at (800) 358-9070. Disassembling the motor or improperly machining the shaft can destroy the motor bearings.

Single-Flex Coupling

When a single-flex coupling is used, one and only one of the shafts must be free to move in the radial direction without constraint. *Do not use a double-flex coupling in this situation because it will allow too much freedom and the shaft will rotate eccentrically; this will cause large vibrations and immediate failure.*

Double-Flex Coupling

Use a double-flexed coupling whenever two shafts are joined that are fixed in the radial and angular direction (angular misalignment). *Do not use a single-flex coupling with a parallel misalignment; this will bend the shafts, causing excessive bearing loads and premature failure.*

Rigid Coupling

Rigid couplings are generally not recommended. They should be used only if the motor is on some form of floating mounts which allow for alignment compensation.

Coupling Manufacturers

HELI-CAL
 901 McCoy Lane
 P.O. Box 1460
 Santa Maria, CA 93456
 (805) 928-3851

ROCOM CORP
 5957 Engineer Drive
 Huntington Beach, CA 92649
 (714) 891-9922

For unusual motor installations contact a Compumotor Applications Engineer for assistance.

Chapter 4. HARDWARE REFERENCE

Chapter Objectives

This chapter is designed to function as a quick-reference tool for the following information:

- System specifications (dimensions & performance)
- Default jumper settings
- System component connections and I/O specifications

System Specifications

This section provides specifications for the C Series Drives and Compumotor-supplied motors. Refer to the *Compumotor Programmable Control Catalog* for torque/speed curves.

C Series Drive Specifications

Parameter	Value
Amplifiers Type Motor resolution Current Rating (per phase) Protection*: Short circuit Brownout Over-temperature Standby current reduction	20 kHz fixed frequency, variable duty cycle, pulse width modulated. Current controlled, unipolar type. MOSFET construction. From 200 to 25,000 steps/rev (jumper-selectable) Standard C Drive = 0.14 - 5.0A; CT Drive = 0.03 - 1.0A (jumper selectable) Phase-to-phase only (not phase-to-ground) If logic supply drops below 8.5V If internal air temperature exceeds 158°F (70°C) 50% of motor current
Command Interface Step Direction Shutdown	Inputs are fully optically isolated and require a TTL-type signal to operate. >3.5VDC = high, <0.8VDC = low. User-supplied indexer must be capable of providing a minimum of 10mA and a maximum of 17mA. High-going pulse, 500 ns min. width. Max. pulse rate is 750 kHz. Logic high = CW rotation; Logic low = CCW rotation Logic high = amplifier disable; Logic low = normal operation
Power Input Logic Supply Motor Supply	Regulated +9 to +24VDC, 0.3A maximum. 250mV max. ripple. Unregulated +12 (min.) to +90VDC(max.). Appropriate supply voltage is a function of the desired top speed and motor inductance. 10% max. allowable ripple.
Environmental Constraints Drive operating conditions Motor (Compumotor-supplied) Storage Humidity	32° - 120°F (0° - 50°C). Max. heatsink temp. is 144°F (65°C) Maximum motor case temperature is 212°F (100°C) -40° - 185°F (-40° - 85°C) 0% - 95% (non-condensing)
Motor Compatibility Type Number of Leads Breakdown voltage (HIPOT) Minimum inductance	2-Phase hybrid permanent magnet (normally 1.8°) 6 or 8 750VAC minimum 2.5 mH (measured center tap to end)
Performance Accuracy Repeatability Hysteresis Velocity Range	±5 arc minutes typical (unloaded, uni-directional) ±5 arc seconds typical (unloaded, uni-directional) Less than 2 arc minutes (unloaded, uni-directional) Depends on motor inductance & supply voltage. 3,000 RPM possible with 90V supply and 3.6 mH motors.

* Shutdown occurs if any of the described conditions exist. To resume operation, first resolve the problem and then cycle power.

Table 4-1. C Series Drive Specifications

C Series Motor Specifications

	Size 34			Size 34			Size 42	
	C57-51	C58-83	C57-102	C83-62	8C3-93	C83-135	C106-120	C106-178
Static Torque oz-in (N-m)	45 (0.32)	80 (0.55)	120 (0.85)	140 (1.00)	260 (1.85)	380 (2.70)	480 (3.40)	700 (4.90)
Rotor Inertia oz-in ² (kg-cm ²)	0.48 (0.088)	1.28 (0.0234)	1.75 (0.0320)	3.50 (0.64)	6.70 (1.23)	10.24 (1.87)	21.5 (3.92)	44.0 (8.05)
Bearings								
Thrust load lb (kg)	25 (11.32)	25 (11.32)	25 (11.32)	50 (22.64)	50 (22.64)	50 (22.64)	50 (22.64)	50 (22.64)
Radial load lb (kg)	15 (6.79)	15 (6.79)	15 (6.79)	25 (11.32)	25 (11.32)	25 (11.32)	25 (11.32)	25 (11.32)
End Play Reversing load Equal to 1 lb in (cm)	0.005 (0.013)	0.005 (0.013)	0.005 (0.013)	0.005 (0.013)	0.005 (0.013)	0.005 (0.013)	0.005 (0.013)	0.005 (0.013)
Radial play Per 0.5 lbs load in (cm)	0.0008 (0.002)	0.0008 (0.002)	0.0008 (0.002)	0.0008 (0.002)	0.0008 (0.002)	0.0008 (0.002)	0.0008 (0.002)	0.0008 (0.002)
Motor Weight (Net) lbs (kg)	1.6 (0.73)	2.4 (1.09)	3.2 (1.45)	3.8 (1.73)	5.12 (2.33)	8.3 (3.77)	8.5 (3.86)	19.11 (8.69)
Total Shipping Weight (Net) lbs Motor/drive + container (kg)	6.0 (31.8)	7.8 (3.54)	8.6 (3.90)	9.2 (4.18)	10.52 (4.78)	13.7 (6.22)	13.9 (6.31)	24.51 (11.14)

Table 4-2. C Series Motor Specifications

CT Series Motor Specifications

	CT25-30	CT27-38	CT32-39
Static Torque oz-in (N-m)	1.84 (0.013)	3.5 (0.025)	7.07 (0.050)
Rotor Inertia oz-in ² (kg-cm ²)	0.0136 (0.0025)	0.0180 (0.0033)	0.0546 (0.0100)
Motor Weight (Net) oz (gm) (kg)	2.47 (70.0) (0.070)	4.76 (135.0) (0.135)	8.82 (250.0) (0.250)

Table 4-3. CT Series Motor Specifications

Default Drive Settings

Drive functions are set with jumpers JU1 through JU12 which are located behind the indexer connector (J2) (see Figure 2-1 in Chapter 2). **C Series Drives are shipped with all jumpers removed.** Table 4-4 below shows the default and recommended jumper settings. Refer to Chapter 2, Getting Started, for adjustment procedures and optional adjustments.

Jumper	Function	Default Setting	Recommended Settings
JU1 through JU5	Current	All Removed (Min. current)*	Depends on motor used
JU6	Auto Run	Removed (Enabled)	Installed (Disabled)
JU7	Auto Standby	Removed (Enabled)	Installed (Disabled)
JU8 through JU10	Motor Resolution	All Removed (200 steps/rev)	25,000 (or highest indexer resolution)
JU11 & JU12	Waveform	Both Removed (Pure sine profile)	No change

* Minimum current is 0.14A for Standard C Drive and 0.03A for CT Drive

Table 4-4. Default and Recommended Jumper Settings

Connector Summary and Pinouts

Figure 4-1 illustrates the pinouts and connectors on the C Series Drive. Table 4-5 shows the motor cable color codes.

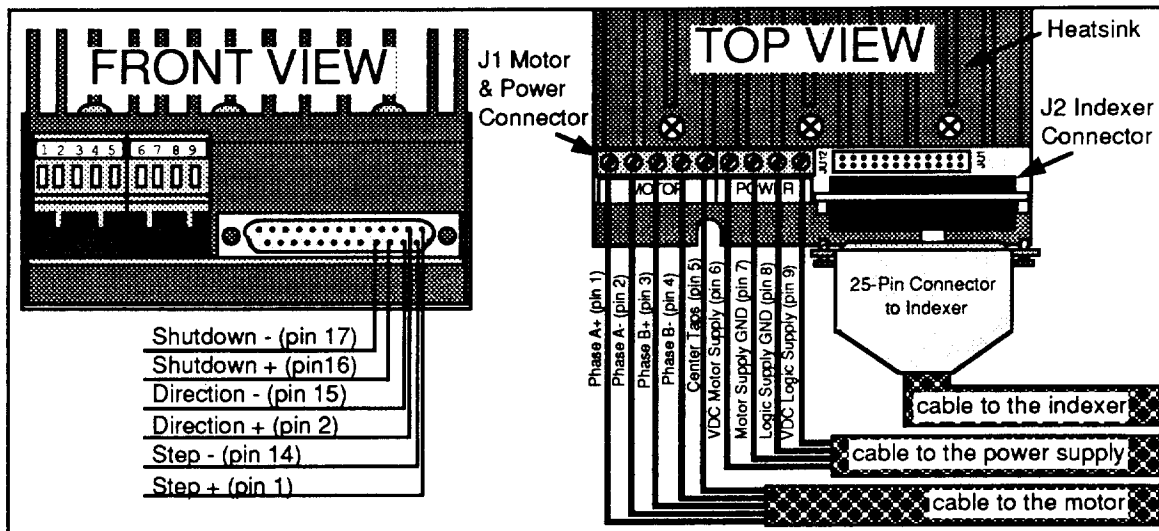

Figure 4-1. C Series Drive Pinouts and Connectors

Motor Cable Color Codes

Table 4-5 below provides the motor cable color codes for the different types of Compumotor-supplied motors.

Pin #	Description	CT25-30 and CT32-39	C57 & C83 Series and CT27-38	C106 Series
1	Phase A+	Red	Red	Red
2	Phase A-	Yellow	Red/White	Black
3	Phase B+	Green	Green	Yellow
4	Phase B-	Blue	Green/White	Green
5	Center Taps*	Brown, Black, White & Violet	White & Black	Orange & Brown

* Center tap wires for both phases should be connected to connector J1, pin #5.

Table 4-5. Compumotor Motor Cable Color Codes

I/O Descriptions

J2 is a 25-pin D connector providing all indexer control inputs. All inputs are optically isolated and require between 10mA and 17mA to turn on @ a minimum of 3.5V (5.5V maximum). Input relationships are described in Table 4-6.

Step+ (pin 1)	Positive-going with reference to Step- (pin 14)
Direction+ (pin 2)	Positive-going with reference to Direction- (pin 15)
Shutdown+ (pin 16)	Positive-going with reference to Shutdown- (pin 17)

Table 4-6. Input Relationships

The C Drive steps the motor one microstep for every pulse received on its step input. The state of the direction input at the time the first step pulse is received determines the rotational direction of the motor shaft. The direction input must be stable for at least 20 μ s before receiving the first step pulse.

CAUTION

When you enable the shutdown input, all current is removed from the motor windings, allowing the shaft to rotate freely (*freewheel*).

I/O Circuit Diagram

Figure 4-2 illustrates the step, direction, and shutdown circuits. The direction input circuit is identical to the shutdown input circuit.

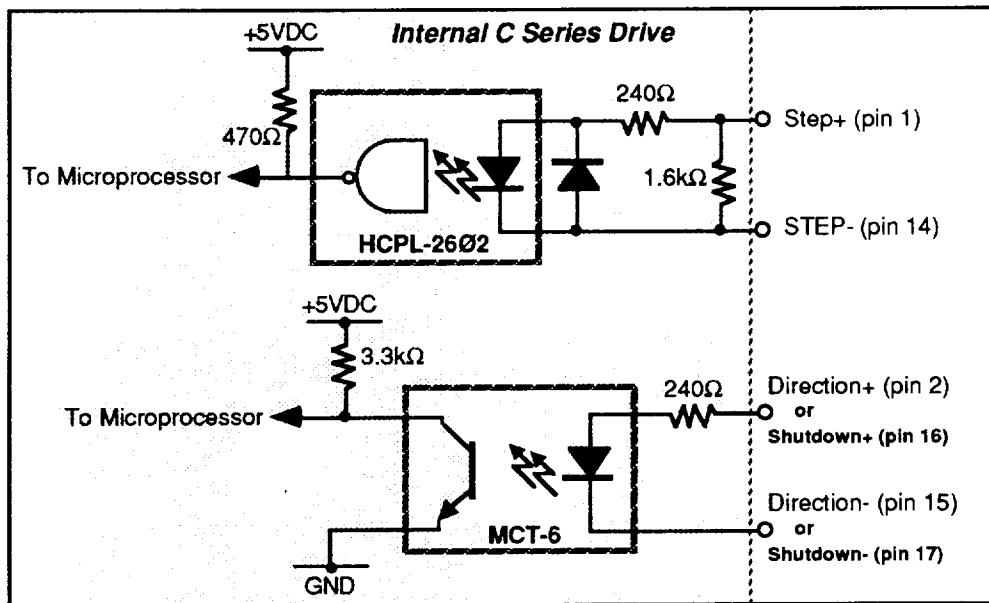

Figure 4-2. Step, Direction, and Shutdown Circuits

Dimensional Drawing

This sections contains the dimension drawing for the C Series Drive (see Figure 4-3). The dimensions for the C Drive and the CT Drive are identical. For motor dimensions, refer to the *Compumotor Programmable Motion Control Catalog*.

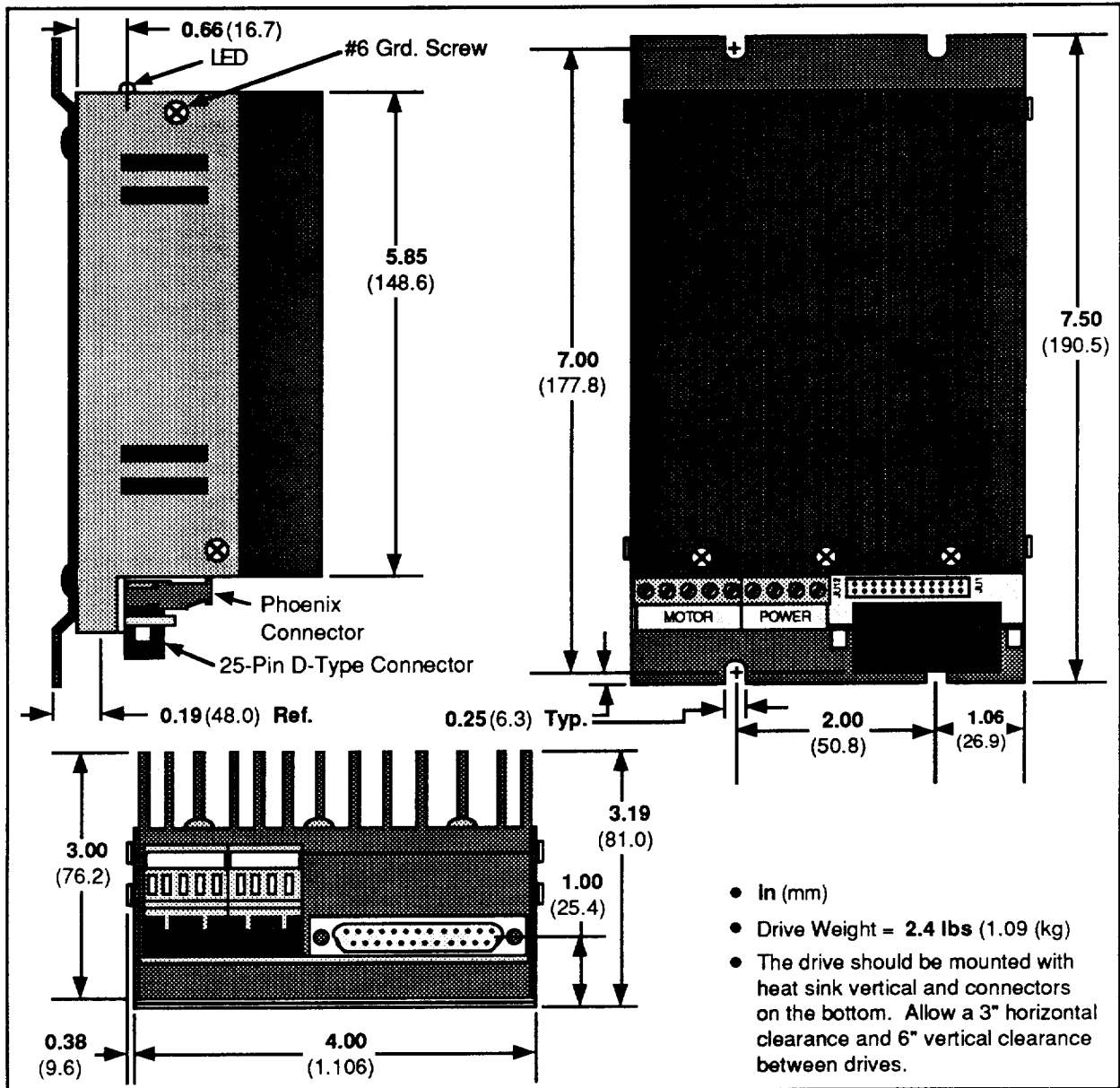

Figure 4-3. C Series Drive Dimensions

Chapter 5. MAINTENANCE & TROUBLESHOOTING

Chapter Objectives

The information in this chapter will enable you to do the following:

- Maintain the system's components to ensure smooth, efficient operation
- Isolate and resolve system hardware problems

Maintenance

The following system components require periodic maintenance:

- The Motor
- The Drive

Spare Parts Table

Table 5-1 provides a list of recommended spare parts to use with the C Series Drive system.

Description	Part Number
Possible Drives: C Drive CT Drive	C-DRIVE CT-DRIVE
DC3 Power Supply (optional)	DC3
Pkg. of 16 Jumpers	43-002435-01
5-pin Phoenix Connector	43-005561-01
4-pin Phoenix Connector	43-005560-01

Table 5-1. Recommended Spare Parts for the C Series Drive System

Motor Maintenance

You should inspect all exterior mechanical parts of the motor regularly to ensure that no bolts or couplings have become loose during normal operation. **Do not disassemble the motor.** This will prevent minor problems from developing into more serious problems.

The ball bearings used in the Compumotor-supplied RM-Series motors are not sealed against severe environments, but are permanently lubricated and do not require any maintenance.

You should inspect the motor cable or leads periodically for signs of wear. This inspection interval is duty-cycle, environment, and travel-length dependent. You should not apply excessive tensile force to the cable. Do not bend the cable beyond a one-inch radius of curvature during normal operation. Tighten all cable connectors.

Drive Maintenance

Check that the drive heatsink is free of particles and has a free flow of air over its entire surface. Enclosures must be connected to earth ground through a grounding electrode conductor to provide a low-impedance path for ground-fault or noise-induced currents. All earth ground connections must be continuous and permanent.

Troubleshooting

Problem Isolation

This section discusses methods to identify, isolate, and resolve problems that may occur with your C Series Drive.

When your system does not function properly (or as you expect it to operate), the first thing that you must do is identify and isolate the problem. When you accomplish this, you can effectively begin to resolve the problem.

Try to determine if the problem is mechanical, electrical, or software-related. *Can you repeat or re-create the problem?* Do not attempt to make quick rationalizations about problems. Random events may appear to be related, but they are not necessarily contributing factors to your problem. You must carefully investigate and decipher the events that occur before the subsequent system problem.

You may be experiencing more than one problem. You must solve one problem at a time. Log (document) all testing and problem isolation procedures. You may need to review and consult these notes later. This will also prevent you from duplicating your testing efforts.

Isolate each system component and ensure that each component functions properly when it is run independently. You may have to remove your system components and re-install them component-by-component to detect the problem. If you have additional components available, you may want to use them to replace existing components in your system to help identify the source of the problem. ***Motors and drives should be replaced as a set. A defective motor can damage a replacement drive, and a defective drive can damage a replacement motor.***

WARNING

Make sure to remove power before disconnecting system components or changing wiring.

Once you have isolated the problem, take the necessary steps to resolve it. Refer to the problem solutions contained in this chapter. If your system's problem persists, contact Parker Compumotor's Applications Department at (800) 358-9070.

Fault LED

The drive diagnostic LED is located on the side of the drive opposite the connectors. This LED indicates a fault when it turns red. The fault condition may be caused by one or more of the following conditions:

- The drive is overheating. You may consider cooling the cabinet to the temperature specified in Chapter 4, Hardware Reference. Installing a fan would help the problem.
- A short circuit exists in the motor current output. Remove power and disconnect the motor. Use an ohm meter to make sure that there is not a short circuit between phase A and phase B, or to earth ground.
- A brownout condition exists. Check to make sure the logic input voltage is high enough (refer to Chapter 4).

Motor Falls to Move

Test the motor to see if it has holding torque. If there is no holding torque, here are some probable causes:

- There is no DC power.
- Current selection jumpers are not set properly (see the motor current selection tables in Chapter 2, Getting Started).
- There are bad connections or bad cables. Disconnect the motor connector, then use an ohm meter to monitor continuity between the motor cables and the drive.
- The shutdown input may be active.

If the unit has holding torque and the motor shaft still fails to move, here are some probable causes:

- The indexer's limit switches have been tripped or are faulty. Make sure that your limit switches are OFF or that the limits are disabled.
- The load is jammed. You should *hear* the drive attempting to move the motor. Remove power from the drive and verify that you can move the load manually away from the point of the jam.
- Indexer parameters are incorrectly set up. If certain parameters are out of range or are missing, the indexer will not send step pulses to the drive when you issue the GO or START command.

The following are additional troubleshooting techniques:

- Check the motor for damage. Also check the motor leads/cable to see if they are damaged or shorted. These conditions may cause the drive to fault.
- Remove power and disconnect the motor. Ohm the motor and cables to make sure that shorts do not exist between phases or to earth ground. The resistance across each motor phase should be consistently low. The resistance between motor phases and between each phase and earth ground should be infinite.

Motor Stalls

A motor stall during acceleration may be caused by one or more of the following factors:

- The torque requirements may be excessive
- The acceleration ramp may be too steep
- The motor supply is too low (12VDC minimum)
- The load inertia and rotor inertia may be grossly mismatched. *The load inertia can be too high or too low.*

Lower acceleration may be required.

If the motor stalls during the constant velocity portion of a move, the shaft and/or coupler may be damaged or binding due to improper coupling or excessive motor load.

A stall may occur if the jumper-selected motor current is incorrect. The motor may not be receiving enough current to operate.

If you are using an encoder with your indexer, a stall may also be detected in closed loop mode if the encoder resolution is not set properly, or if the encoder input channels are reversed.

Motor Fails to Run at High Speeds

If the motor fails to run at high speeds, it is possible that the motor may not produce enough torque to move a given load at these velocities. Check the torque/speed curves in the *Compumotor Programmable Motion Control Catalog* and make sure you are trying to run the motor in the proper range.

Motor Is Jerky or Weak

Check that there are no mechanical problems at the load causing highly variable loading condition. Disconnect the motor from the load and run it without a load connected. Command the indexer to stop all motor motion and try to manually turn the motor shaft; this will determine if the motor is maintaining full holding torque. Verify that the jumper-selected current setting is correct.

Motor Overheats

If the motor exceeds its maximum motor case temperature rating, failure will eventually result. Check your jumper settings to ensure that the current setting is correct for the motor you are using. Refer to Chapter 2, Getting Started, for proper current settings.

Motor Shaft Wears

The motor shaft may wear prematurely if there is foreign material rubbing against the shaft, or if the load is not coupled properly.

Reducing Electrical Noise

For information on identifying and suppressing electrical noise, refer to the Technical Data section of the *Compumotor Programmable Motion Control Catalog*.

Returning The System

If you must return your C Series Drive system to effect repairs or upgrades, use the following steps:

- STEP 1** Get the serial number and the model number of the defective unit, and a purchase order number to cover repair costs in the event the unit is determined by Parker Compumotor to be out of warranty.
- STEP 2** Before you ship the drive to Parker Compumotor, have someone from your organization with a technical understanding of the C Series Drive system and its application include answers to the following questions:
- What is the extent of the failure/reason for return?
 - How long did it operate?
 - How many units are still working?
 - How many units failed?
 - What was happening when the unit failed (i.e., installing the unit, cycling power, starting other equipment, etc.)?
 - How was the product configured (in detail)?
 - What, if any, cables were modified and how?
 - With what equipment is the unit interfaced?
 - What was the application?
 - What was the system sizing (speed, acceleration, duty cycle, inertia, torque, friction, etc.)?
 - What was the system environment (temperature, enclosure, spacing, unit orientation, contaminants, etc.)?
 - What upgrades, if any, are required (hardware, software, user guide)?
- STEP 3** Call Parker Compumotor for a Return Material Authorization (RMA) number. Returned products cannot be accepted without an RMA number. The phone number for Parker Compumotor Applications Department is (800) 358-9070.
- STEP 4** Ship the unit to:
- Parker Compumotor Corporation
5500 Business Park Drive
Rohnert Park, CA 94928
Attn: RMA # xxxxxxxx

Index

- Acceleration, 24
- Amplifier, 10
- Atmospheric contamination, iv
- Auto Run mode, 6
- Auto Standby mode, 2, 7

- Basic electronics, iii
- Basic motion control, iii
- Brownout protection, 15, 23

- C Drive description, 1
- Change summary, ii
- Circuits, 18
- Clearance (for mounting drive), 11
- Compumotor-supplied motors, 3
- Connector summary and pinouts, 17
- Connectors, 17
- Coupling manufacturers, 14
- Coupling the load, 13
- CT Drive description, 1
- Current selection jumpers, 23

- DC3 power supply, 1
- Default and recommended jumper settings, 17
- Dimension drawing, 19
- Direction input, 9, 18
- Drive diagnostic LED, 23
- Drive dimensions, 19
- Drive functions, 4
- Drive maintenance, 21
- Drive mounting, 11
- Drive resolution, 10
- Drive Specifications, 15

- Earth ground, 12
- Electrical noise, iv, 24

- Fan cooling, 11
- Fault LED, 23
- Features, 2
- Functional test, 10

- Grounding, 12, 13

- Heatsink, 11
- Holding torque, 10

- I/O circuit diagram, 18
- I/O descriptions, 18
- Indexer connections, 9
- Indexer control inputs, 28
- Indexer parameters, 23
- Indexer resolution, 7, 10
- Inductance, 1
- Installation recommendations, iv

- Jumper-selected motor current, 24
- Jumpers, 4

- LED, 10
- Load inertia, 24

- Maintenance, 21
- Minimum phase inductance, 1
- Misalignments, 13
- Motor cable color codes, 8
- Motor compatibility, 1
- Motor connections, 8
- Motor current settings, 4
- Motor dimensions, 19
- Motor problem troubleshooting, 23-24
- Motor maintenance, 21
- Motor overheating, 24
- Motor resolution values, 7
- Motor specifications, 16
- Motor supply, 24
- Motor waveform settings, 7
- Mounting, 11

- Output current, 1
- Over-temperature protection, 10, 15
- Overheating, 23

- Phase current, 1
- Pinouts, 17
- Power supply connections, 9
- Power supply wires, 12
- Power-up (applying power), 10
- Problem isolation, 22

- Repairs, 25
- Resolution, 2, 7, 10
- Return Material Authorization (RMA) number, 25
- Returning the system, 25
- Rotor inertia, 24

- Shaft couplings, 14
- Shielding, 12
- Ship kit, 3
- Short circuit protection, 10, 15, 23
- Shutdown input, 9, 10, 23
- Spare parts, 21
- Specifications, 15
- Step input, 9, 18
- Step pulse, 9
- Stepper motors, 1
- Supply voltage, 1
- System connections, 8

- Testing the drive, 10
- Torque requirements, 24
- Torque/speed curves, 15
- Troubleshooting, 22

- Wiring guidelines, 12

