

APPENDIX C

Regulatory Compliance: UL and CE

IN THIS CHAPTER

- Installation Instructions
 - Installation Guidelines
 - System Installation Techniques
-

Regulatory Agencies

The Gem6K family of products is designed to meet the requirements of global regulatory agencies.

Gem6K products have shown compliance with the requirements of the regulatory agencies in the following list. The list also shows additional steps users must take to ensure compliance.

Agency	Additional Steps User Must Take
UL, cUL	Mains fuses
CE (LVD)	Mains fuses; earth connection for drive and motor (if applicable), proper installation
CE (EMC)	Varistors, mains filter, EMC cabling, EMC ready motor, proper installation

Installation Instructions

Although Gem6K drives are technically considered motion control components and are therefore not within the scope of the European union's CE (Conformité Européenne) directives, Compumotor has taken the initiative to provide its customers with easy to integrate motion control products that meet global requirements.

The following constitutes what is typically required to install Gem6K drives into a CE compliant system. Additional installation measures may be required at some locations. The machine builder has ultimate responsibility for machine compliance.

Low Voltage Directive (LVD) Installation Requirements:

- Mains fuses
- Drive safety earth conductor
- Motor safety earth (for motor voltages greater than 75 volts)
- Drive must be installed such that the hazardous live terminals (barrier strip) are not accessible under normal operation

Electromagnetic Compatibility (EMC) Installation Requirements:

- Product does not need to be placed within an enclosure
- Mains filter (see filter recommendations)
- Transient suppressors (mains surge test)
- Compumotor EMC cabling (requires no special cable preparation)
- EMC ready motor, or motor with EMC installation information
- Additional installation hardware as shown in drawings in this *Appendix*

Additional Steps to Ensure Compliance

To meet the requirements of regulatory agencies, you *must* follow the installation guidelines presented below.

Mains Fuses

Instructions for installing mains fuses were presented in *Connecting AC Power in Chapter 2 Installation*.

EMC – Electromagnetic Compatibility Directive – 89/336/EEC

In order to meet the requirements of the Electromagnetic Compatibility Directive 89/336/EEC, the entire system must comply: motor, drive, cabling, and peripherals. The installation of the product must include the following items.

EMC Cabling

For electromagnetic compatibility, you must use Parker Compumotor CE cables.

NOTE: Parker Compumotor does not sell a cable for the Master Encoder connector. Use a high quality braided shield cable if you make connections to the Master Encoder connector.

EMC Motor

For system CE compliance, you must use an EMC-ready motor, or a motor that has demonstrated acceptable EMC performance.

NOTE: Motors may bear the CE mark. This mark indicates the motor meets the requirements of construction and safety—not *EMC compliance*.

Motors with shielded cabling or pipe thread style cabling options allow the easiest integration into machines required to bear the CE mark for EMC.

Varistors

You must install varistors or other voltage surge limiting devices in order to meet the requirements of EN61000-4-5. Place a Littelfuse V275LA2Ø or equivalent varistor from line to line, and from lines to earth before the mains filter, as shown in the *EMC Installation* drawings later in this appendix. (Intersil, General Electric and Littelfuse manufacture equivalent varistors.)

Mains Filter

You must install a mains filter. The next table lists recommended filters.

Filter:	Continuous Current (amps)	GV6K-L3 GV6K-U3	GV6K-U6 GT6K-L5	GT6K-L8	GV6K-U12	GV6K-H20	GV6K-H40
3EP1 ¹	3	X					
6EP1 ¹	9	X	X				
10EP1 ^{1,3}	10	X	X	X			
FN2070-10-06 ²	10	X	X	X	X		
FN2070-12-06 ²	12	X	X	X	X		
FN2070-16-06 ^{2,3}	16	X	X	X	X		
16FCD10 ¹	16					X	
FN351-16/29 ²	16					X	
FN351-25/29 ²	25						X
25FCD10 ¹	25						X
36FCD10 ¹	36						X
FN351-36/29 ²	36						X

Product with applicable mains filter denoted by “X”

¹ Corcom; ² Schaffner;

³ Available from Compumotor: 10 amp filter – part number 47-016140-01
16 amp filter – part number 47-017900-01

+24VDC Power Supply

If you use the +24VDC power supply Parker Compumotor offers for sale (PS-60W), no additional filter is required on the +24VDC mains. If you use another manufacturer’s +24VDC power supply, it should be CE marked for safety and electromagnetic compatibility.

Installation Guidelines

Gem6K drives are made available under “Restricted Distribution” for use in the “Second Environment” as described in BS EN 61800-3: 1996, page 9.

Cabinet Mounting

For Electromagnetic Compatibility, cabinet mounting is not required. However, Gem6K drives have high voltage terminals—for safety purposes, the drive must not be user accessible during normal operation.

Drive Mounting

The Gem6K drive is designed to be mounted to an earthed metal panel. For EMC performance, mount the mains filter to the same panel, as close to the drive as possible. See the *EMC Installation* drawing at the end of this appendix.

Cable Routing

Route high power cables (motor and mains) at right angles to low power cables (communications and inputs/outputs). Never route high and low power cables parallel to each other.

Cable Shielding

All cables must maintain high integrity 360 degree shielding. Compumotor CE cables are fully shielded and provide the required screening. When you install limit switches and other inputs/outputs, you must observe proper noise immunity standards. See the *EMC Installation* drawing at the end of this appendix.

Ethernet Cables

Install a ferrite ring core (toroid) on your Ethernet cable. Wrap the cable through the ferrite eight times, as shown in the installation drawings. Make the cable length between the ferrite and drive as short as possible.

A recommended toroid is listed below, along with its specifications.

Manufacturer:	Phillips; part number TL42/26/13-3C90 4330 030 35522 MU
Material:	3C90
A_L :	$2690 \pm 25\%$ nH
μ_r :	≈ 2300

The ferrite you choose must meet or exceed the specifications above.

Ferrite Absorbers

To further increase product immunity and reduce product emissions, you must add clip-on or other ferrite absorbers to certain cables. (See the installation drawings at the end of this appendix for specific locations.) Compumotor recommends a ferrite with at least 200 ohm impedance at 100 MHz, such as:

Steward Ferrite	part number 28A2024
Fair-Rite	part number 0443164151

(These ferrites are available from Compumotor, part number 47-015956-01)

Expansion I/O

For EMC-sensitive applications requiring expansion I/O, or CE compliant installations, use Parker Compumotor’s EVM32-II.

Enclosure Mounting the Gem6K Drive

The enclosure must be properly earthed and paint must be removed from drive mounting and RF earth bonding locations. Proper shield termination of all cables entering and exiting the enclosure is required. The motor shield (braid) must be fastened to the drive using the included saddle clamp or R-Clamp. The shield must not make contact with other conductors, as this will cause common mode drive generated PWM current to flow where not expected. The shields of all other cables that enter or exit the enclosure must be RF bonded to the enclosure entrance point via R-Clamp, bulkhead clamshell clamp, or other 360° bonding technique. This ensures that no stray noise will enter or exit the enclosure. The next drawing illustrates 360° bonding techniques.

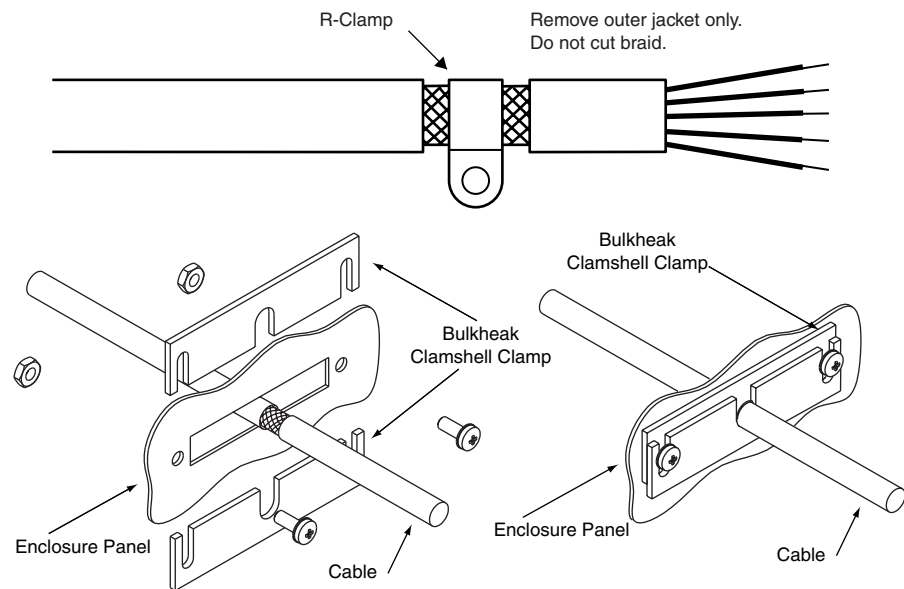

360° Bonding Techniques

The following clamps and clamp kits are available from Compumotor.

Clamp Type:	Compumotor Part Number:
R-Clamp	58-016050-01
R-Clamp Kit (10 per)	R CLAMP KIT
Bulkhead Clamshell Clamp	53-016131-01
Clamshell Clamp Kit (2 per)	CLAMSHELL KIT
Saddle Clamp	53-017355-01

If you use the GEM-VM50 or other screw terminal cable breakout device, be sure to properly enclose all exposed conductors to avoid contamination and to reduce the risk of electrostatic discharge. Limit switches and other I/O must utilize high quality shielded cabling (85% braid coverage minimum), which must be RF earth bonded as shown above.

Panel Mounting the Gem6K Drive

The mounting panel must be properly earthed and paint must be removed from drive mounting locations. Gemini CE cables maintain proper RF bonding with the drive when you insert them in the correct location and tighten the headshell

jackscrews. You must fasten the motor shield (braid) to the bottom of the drive, using the included saddle clamp. (GV6K-H20/H40: R-clamp on heatsink.) The shield must not make contact with other conductors, as this will cause common mode drive generated PWM current to flow where not expected.

If you use the GEM-VM50 or other screw terminal cable breakout device, be sure to properly enclose all exposed conductors to avoid contamination and to reduce the risk of electrostatic discharge. Limit switches and other I/O must utilize high quality shielded cabling (85% braid coverage minimum), which must be RF earth bonded as shown in the *360° Bonding Techniques* drawing.

System Installation

If you mount the Gem6K drive in an enclosure, terminate cable braids (screens) at the entrance of the enclosure. However, the motor braid *must* be returned to the drive's saddle clamp (GV6K-H20n/H40n: R-Clamp on heatsink), not any other location.

The next figures show typical EMC installations.

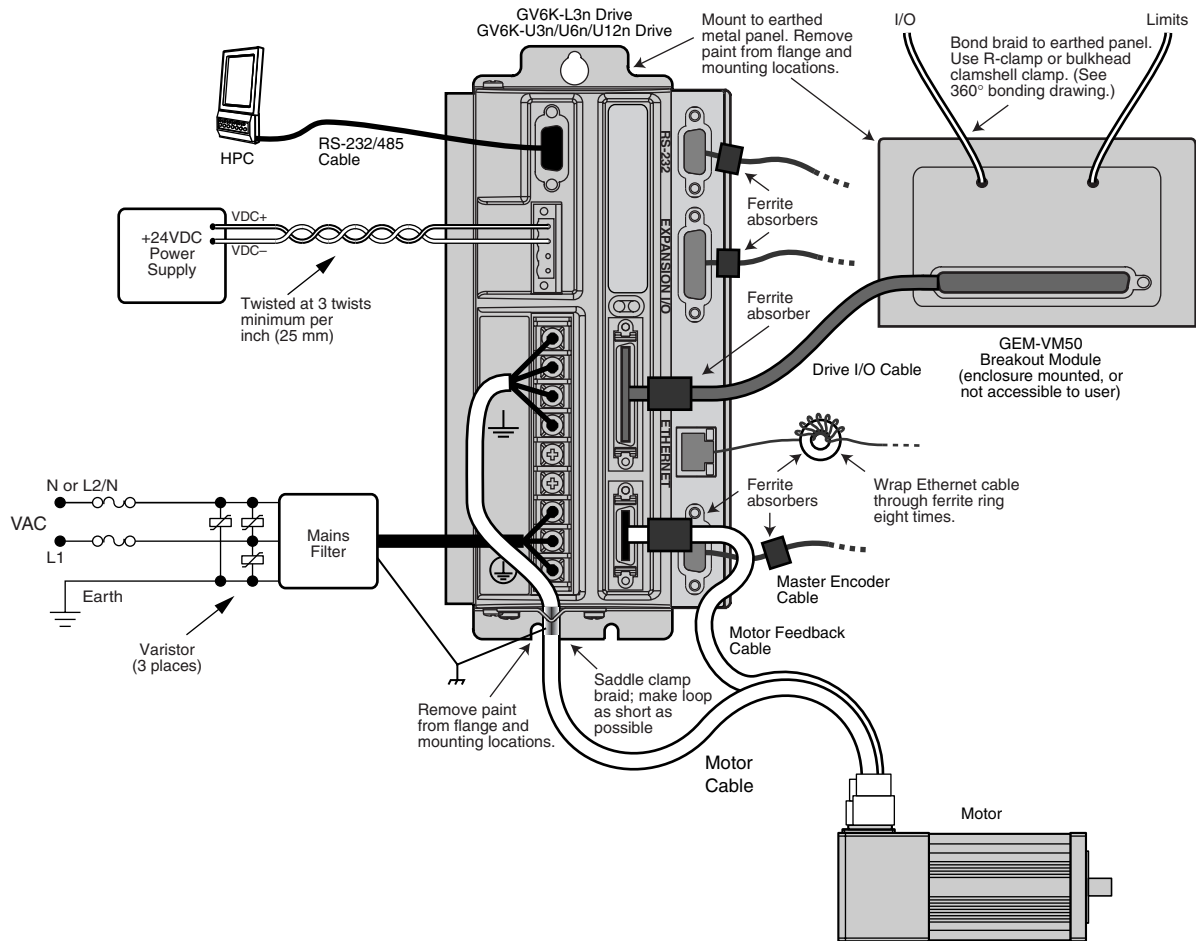

EMC Installation – GV6K-L3n; GV6K-U3n/U6n/U12n

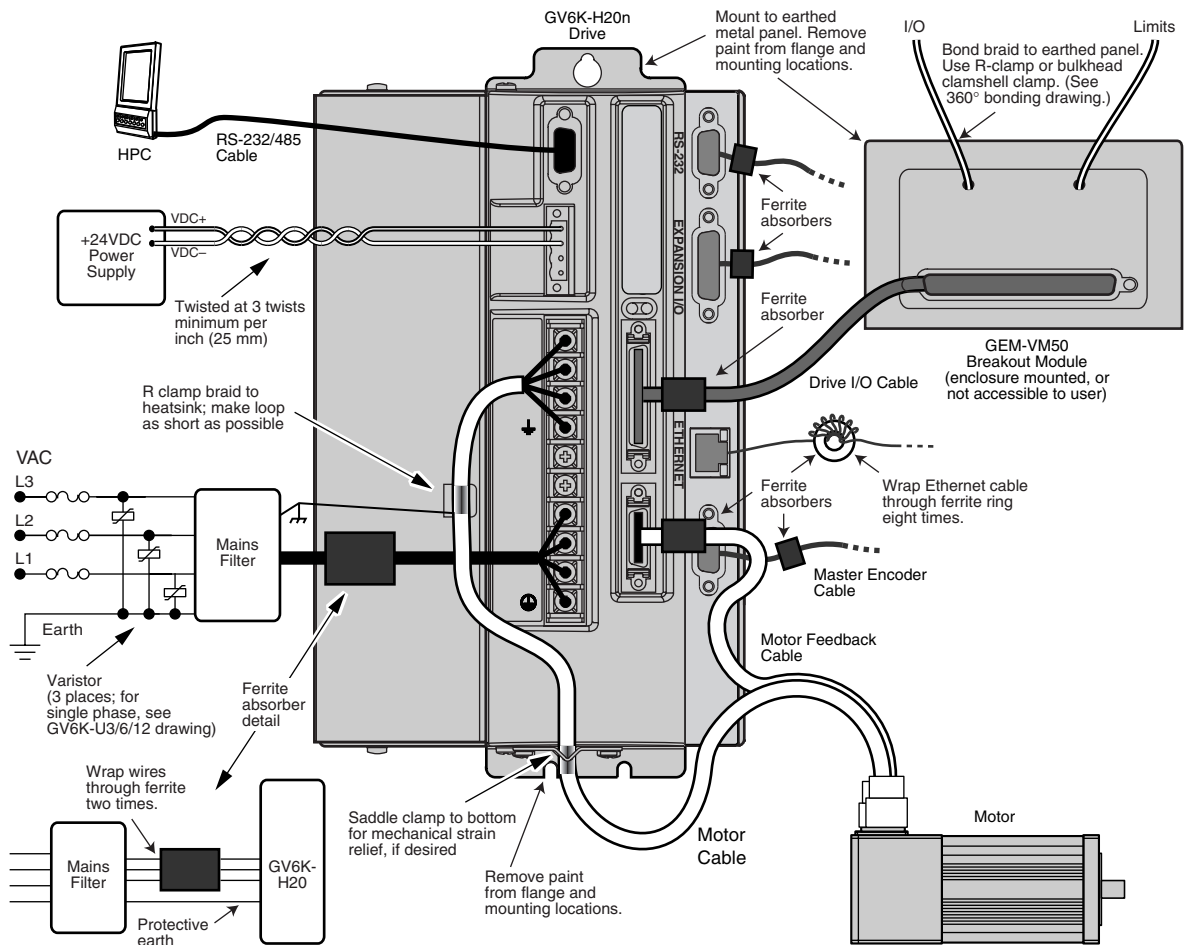

EMC Installation – GV6K-H20n

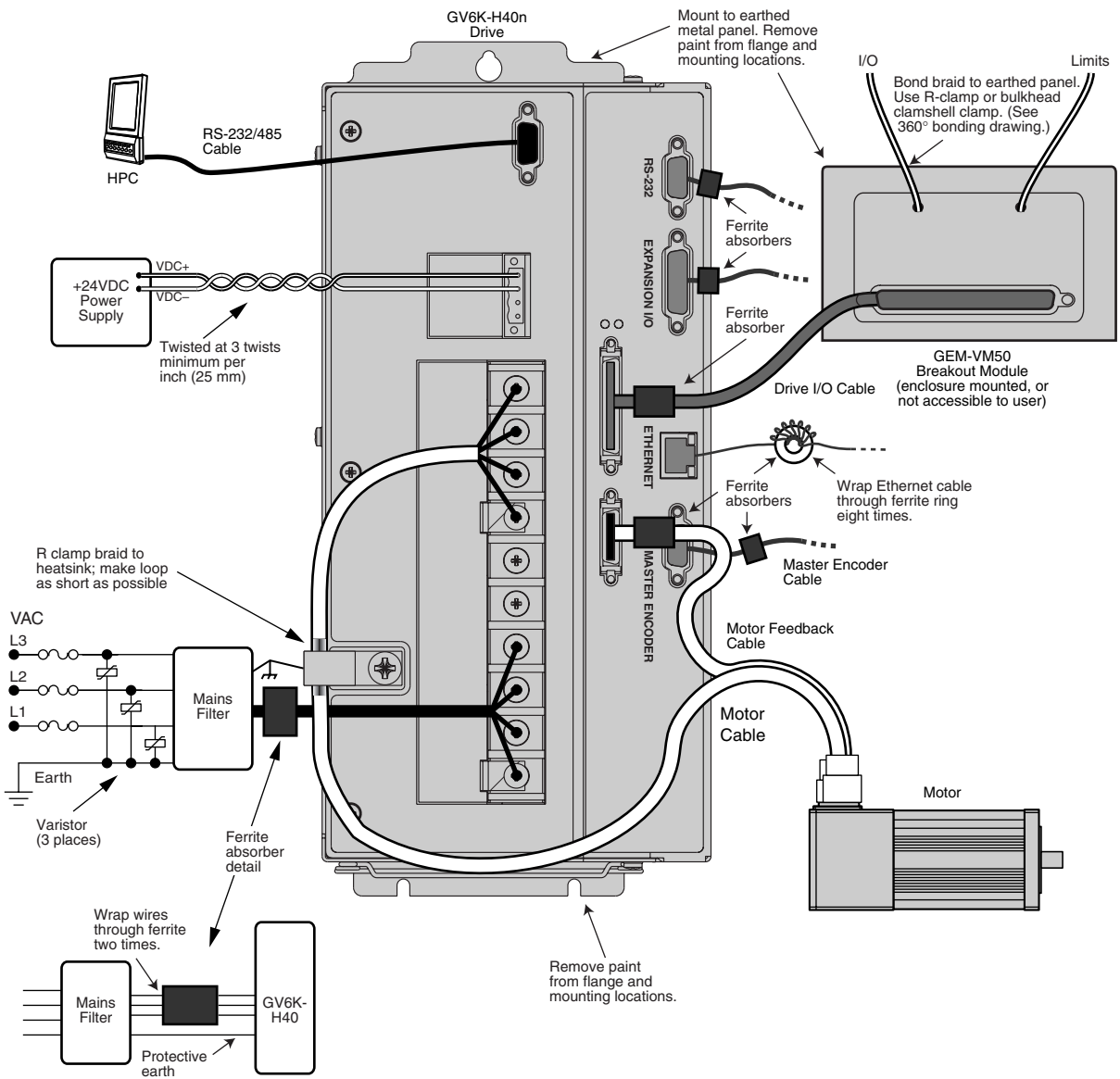

EMC Installation – GV6K-H40n

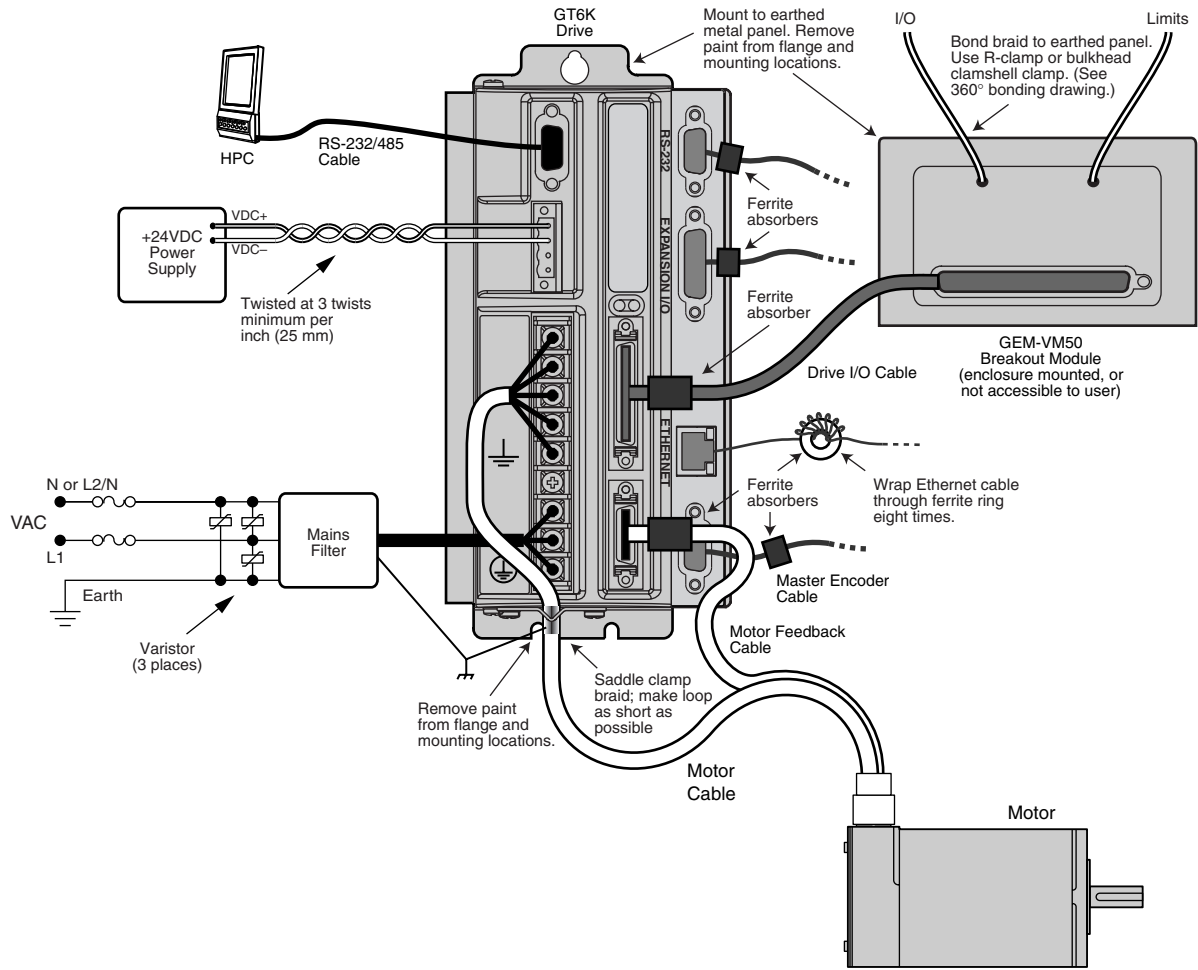

EMC Installation – GT6K