

APPENDIX A

Specifications

IN THIS APPENDIX

- Gemini Drive Specifications
 - Input/Output Specifications
 - Dimensions
 - Protective Circuits
 - Cable Specifications
-

Power Specifications

Input Power

AC

Drive	AC Input Range
GT-L5	95VAC – 132VAC, 50/60 Hz, single phase
GT-L8	95VAC – 132VAC, 50/60 Hz, single phase
GT-U5	95VAC – 132VAC and 190VAC – 264VAC, 50/60 Hz, single phase
GT-U8	95VAC – 132VAC and 190VAC – 264VAC, 50/60 Hz, single phase

Connector

Drive connector: #8 (M4) screw terminals.
Mating terminals: spade fork, 0.325" maximum width



CAUTION



Do not operate GT-U5/8 in the 132VAC – 190VAC range, or the drive will be permanently damaged.



CAUTION



You must connect V DBL to L2/N on GT-U5/8 to enable the voltage doubler for 120VAC operations.



CAUTION



Do not operate GT-L5/8 above 132VAC, or the drive will be permanently damaged.

+24VDC “Keep Alive” Power

Input voltage range: 19.2 – 28.8 VDC
Input current: 500 mA (maximum)

Output Power

Drive	Output Current (amps, peak)	Output Voltage (motor bus) (DC, rms)
GT-U5	5.0	74
GT-U8	7.5	74
GT-L5	5.0	170
GT-L8	8.0	170

Connector

Drive connector: #8 (M4) screw terminals.
Mating terminals: spade fork, 0.325" maximum width

Interface/Communication

Connector

Drive connector: 9 pin D-subminiature plug.
Mating connector: 9 pin D-subminiature receptacle

RS-232:

Rx, Tx, Gnd
9600 baud
8 data bits
1 stop bit
no parity
full duplex

RS-485:*

4-wire plus ground (Rx+, Rx-, Tx+, Tx-, Gnd)
9600 baud
8 data bits
1 stop bit
no parity
full duplex

*twisted pair cabling recommended (e.g. Belden 9842)

Performance

Accuracy: ± 5 arc min (0.0833°), typical unloaded bi-directional with Compumotor motors. Other motors may have different absolute accuracy.

± 1 arc minute (0.0167°), loaded in addition to unloaded accuracy, per each frictional load equal to 1% rated torque.

Repeatability: ± 5 arc sec (0.0014°), typical unloaded one revolution returning to starting point from same direction

Hysteresis: Less than 2 arc min (0.0334°) unloaded bi-directional

Resolution: User definable integer value between 200 and 128,000 steps per revolution

Waveform: -20% through 10%, 0.01% resolution, continuously variable, 3rd harmonic, (use DWAVEF command)

Amplifier

Type: 20 kHz fixed frequency, variable duty cycle PWM, current controlled, recirculating, bipolar type, MOSFET construction.

2 Phases: bipolar motor configuration only.

Auto Standby: When enabled, motor current reduces to a percentage of present value (defined by DAUTOS command), when no step pulses are received for one second. Default is disabled (no current reduction). See DAUTOS command.

Environmental Specifications

Operating Temperature: Still Air: 45°C (113°F) maximum
Moving air: 50°C (122°F) maximum
Minimum: 0°C (32°F)

Storage Temperature: -40°C – 85°C (-40°F – 185°F)

Humidity: 0 – 95%, non-condensing

Shock: 15g, 11msec half sine

Vibration: 10 – 2000 Hz at 2g

Standards

UL, cUL	508C	
CE for LVD	72/23/EEC	
		BS EN61010-1:1993/A2:1995 (ie includes 1995 amendment AMD 8961) Safety requirements for electrical equipment for measurement, control, and laboratory use Part 1. General requirements
CE for EMC	89/336/EEC	
	BS EN61800-3: 1997	Adjustable speed electric power drive systems Part 3. EMC product standard including specific test methods.
	IEC 61800-3: 1996	Adjustable speed electric power drive systems Part 3. EMC product standard including specific test methods.

Inputs and Outputs

This section describes all inputs and outputs (I/O) located on the 50 pin DRIVE I/O connector. Not all are required for your system to operate. The next drawing summarizes which are required, and which are optional.

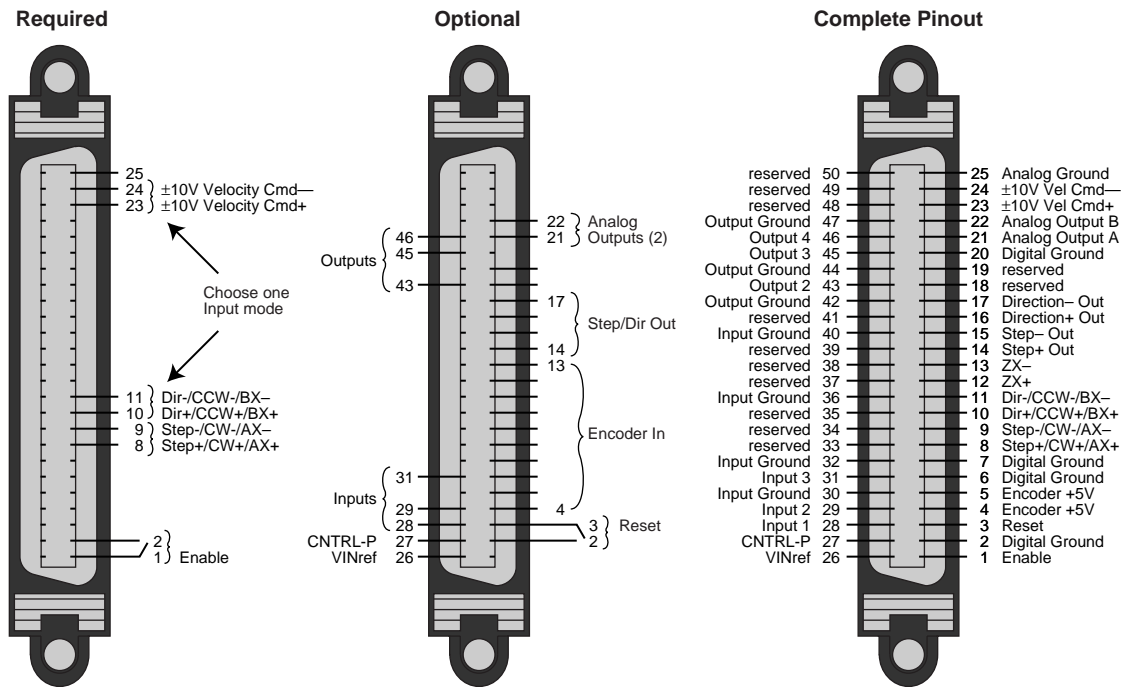

Drive I/O Connector

Connector specifications are:

Manufacturer:	Gemini Drive: AMP	Mating Connector* (not provided; see note): AMP
Connector Type:	CHAMP .050 Series II	CHAMP .050 Series II
AMP Part Number:	2-178238-7	2-175677-7
Wire Gauge:	not applicable	use 28 AWG (0.08 mm ²)

* Note: Mating connectors are not provided with Gemini drives; Compumotor cables are available with mating connectors attached. If you make your own cables, you must use a "jack screw" style fastener, not "spring clip" style. For connector integrity, we recommend you use AMP brand connectors.

Command Input (required)

The Gemini drive can accept several types of command input signals. Use the DMODE command to configure your drive to accept either a pulse input (step/direction, clockwise/counterclockwise, or encoder), or $\pm 10V$ velocity command.

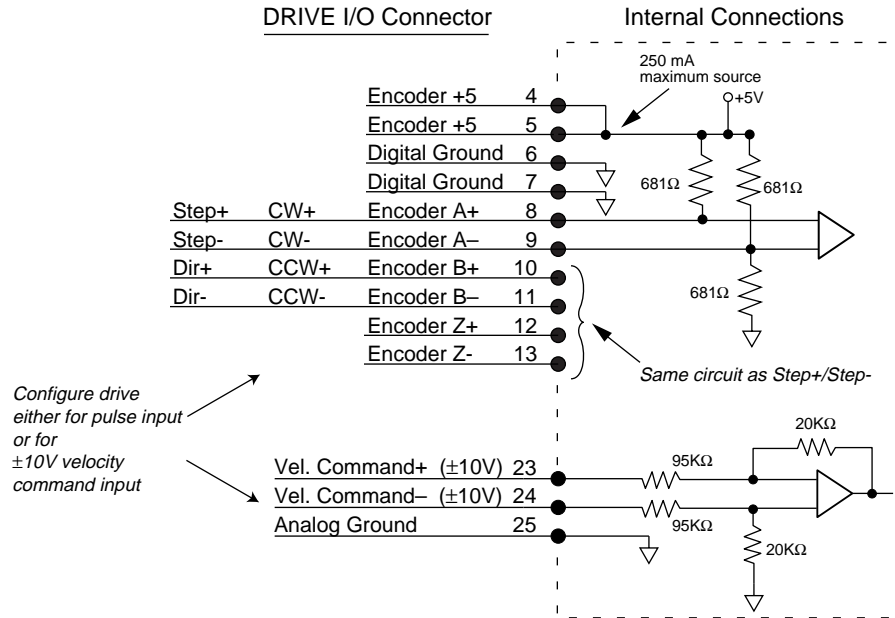

Command Inputs

If you use a pulse source to generate step/direction, CW/CCW or encoder tracking signals, note that the drive's pulse inputs use differential receivers without opto-couplers. For best performance, follow these instructions:

Connection Instructions for Pulse inputs

1. Connect your control's logic ground to the Gemini's ground, pin 6 or 7. This connection ensures that the signals stay within the common mode range of the differential receivers, and must not be omitted.
2. If you use a Compumotor 6K Controller, use the step and direction command cable. See *Cable Specifications* later in this appendix for part numbers.

If you use $\pm 10V$ velocity command input signals, follow these instructions:

Connection Instructions for $\pm 10V$ Velocity Command Inputs

1. Connect COMMAND+ to pin 23.
2. Connect COMMAND- to pin 24.
3. Connect your controller's analog ground reference to pin 25.
4. Use the flying lead cable to connect the 50 pin DRIVE I/O connector to your controller. See *Cable Specifications* later in this appendix for part numbers.

Enable Input (required)

To enable the drive and energize the motor, you must connect the enable input (pin 1) to digital ground (pin 2). The next drawing shows the internal circuit.

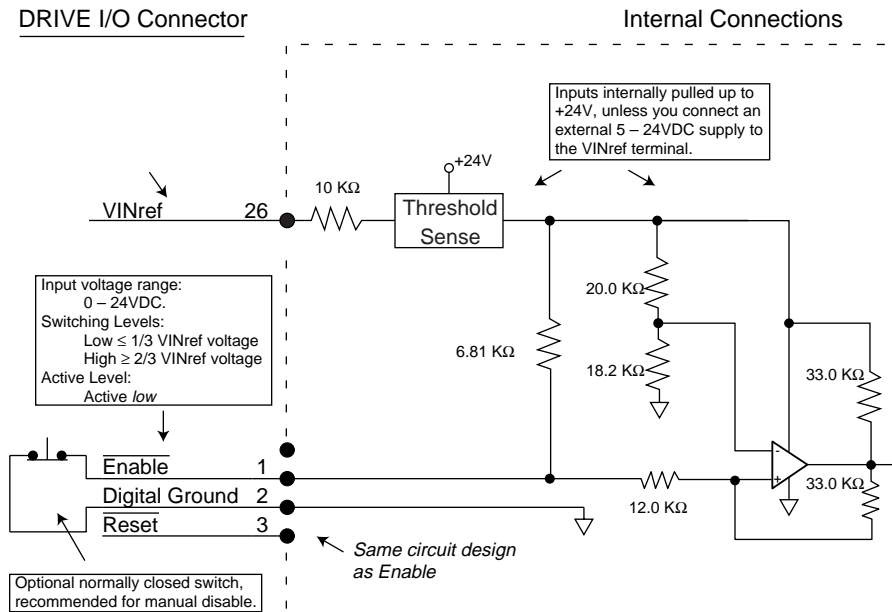

Enable Input and Reset Input

Reset Input (optional)

The reset and enable inputs use the same circuit design, as the drawing above shows. To reset the drive, temporarily connect the reset input (pin 3) to digital ground (pin 2). Reset begins when pin 3 is grounded. The drive will begin its power up sequence upon disconnection of pin 3 from ground.

VINref – Voltage Input Reference (optional)

Use VINref (pin 26) to set the input reference voltage for the enable, reset, and digital inputs.

It is not necessary for you to make connections to VINref. If you connect nothing, then the enable, reset, and inputs are internally pulled up to +24VDC. This is the factory default condition.

If you connect an external 5 – 24VDC power supply to VINref, then the input switching thresholds become:

$$\text{Low} \leq 1/3 * \text{VINref}$$

$$\text{High} \geq 2/3 * \text{VINref}$$

(Default, with VINref at internal +24VDC: Low < 8V; High > 16V)

Digital Inputs (optional)

The Gemini drive has three digital inputs. Their functions are:

Input 1	Positive Limit Input
Input 2	Negative Limit Input
Input 3	User Fault Input

By default, these are +24VDC sourcing inputs. You can use VINref (pin 26) to change the switching voltage level. You can also use CNTRL-P (pin 27) to change the inputs from sourcing to sinking inputs. All connections are shown in the next drawing.

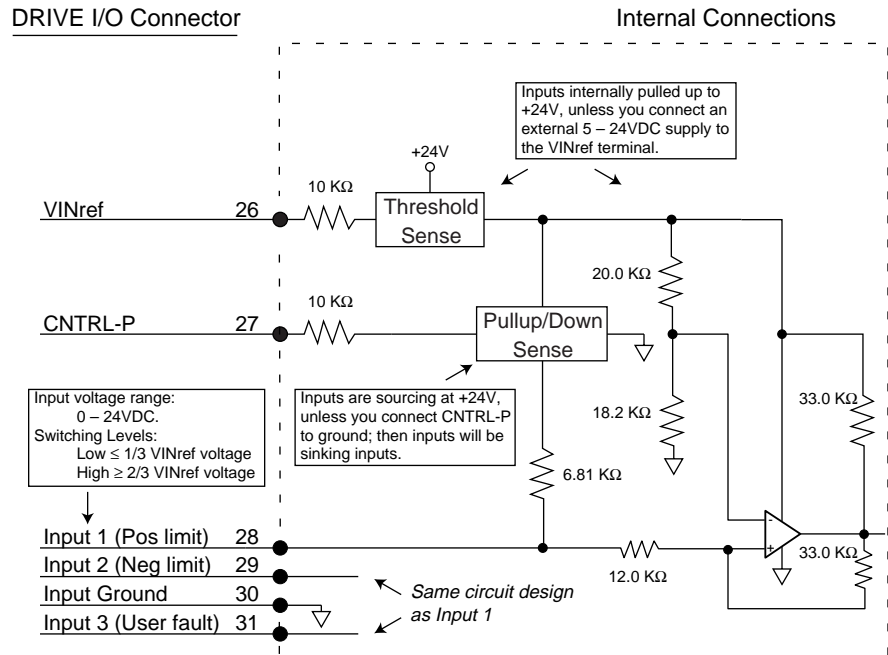

Inputs

You can use the INLVL and INDEB commands to configure the inputs as active high or active low, and to set the debounce time, respectively.

CNTRL-P – Reference for Digital Inputs (optional)

Use CNTRL-P (pin 27) to change the digital inputs from sourcing inputs to sinking inputs.

It is not necessary for you to make any connections to CNTRL-P. If you connect nothing, then the inputs are internally pulled up to VINref. If sourcing inputs are appropriate for your application, then make no connections to CNTRL-P.

If you connect CNTRL-P (pin 27) to digital ground (pin 30), then the inputs will become sinking inputs, and will sink current.

Digital Outputs (optional)

The Gemini drive has three digital outputs. Their functions are:

- Output 2* Drive Fault Output
- Output 3* At Limit
- Output 4* Position Error Output

* For compatibility with other Compumotor products, the outputs are numbered 2, 3 and 4, rather than 1, 2 and 3.

All connections are shown in the next drawing.

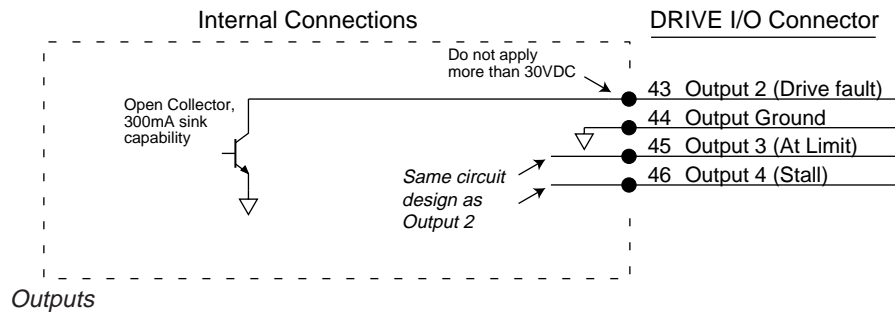

Outputs

You can use the OUTLVL command to configure each of the outputs as active high or active low.

Step & Direction Output (optional)

Pins 14 – 17 are step and direction outputs.

They are derived from incoming command pulses (step/direction, CW/CCW, or encoder inputs). The outputs are based on calculated position.

Step & Direction Output Specifications:

- Default Resolution: 25,000 steps per revolution
- Clockwise Rotation: Direction+ = High
- Counterclockwise Rotation: Direction+ = Low

The step and direction output circuit is shown in the next drawing.

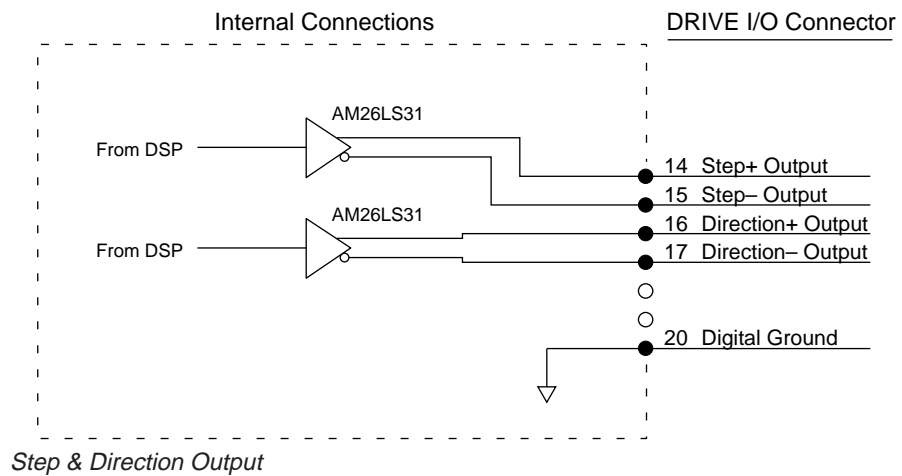

Step & Direction Output

You can use the ORES command to configure the step and direction outputs.

Analog Monitor (optional)

Two analog monitor outputs are available on pins 21 and 22. Use pin 25 as a ground reference for these monitors.

Analog Monitor Specifications:

Maximum Output: $\pm 10V$ (scalable; use DMON command)

Resolution: 8 bits peak to peak (for full scale signal)

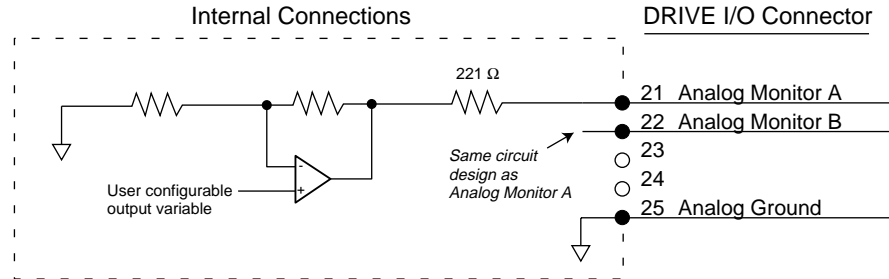

Analog Monitors

You can configure the analog outputs to monitor many different variables, such as current, velocity, temperature, etc. You can also scale the outputs. See the DMON commands in *Chapter 3 Configuration* and the *Gemini Programmer's Reference* for more information.



WARNING



Do not use Analog Monitors as control signals. Because of offsets, limited resolution and accuracy, use the analog monitor outputs only for oscilloscope monitoring.

Connecting Feedback Devices

Gemini GV servo products use the 26 pin MOTOR FEEDBACK connector. The Gemini GT step motor drive does not use the MOTOR FEEDBACK connector. You do not need to make connections to this connector.

Dimensions

Drive Dimensions

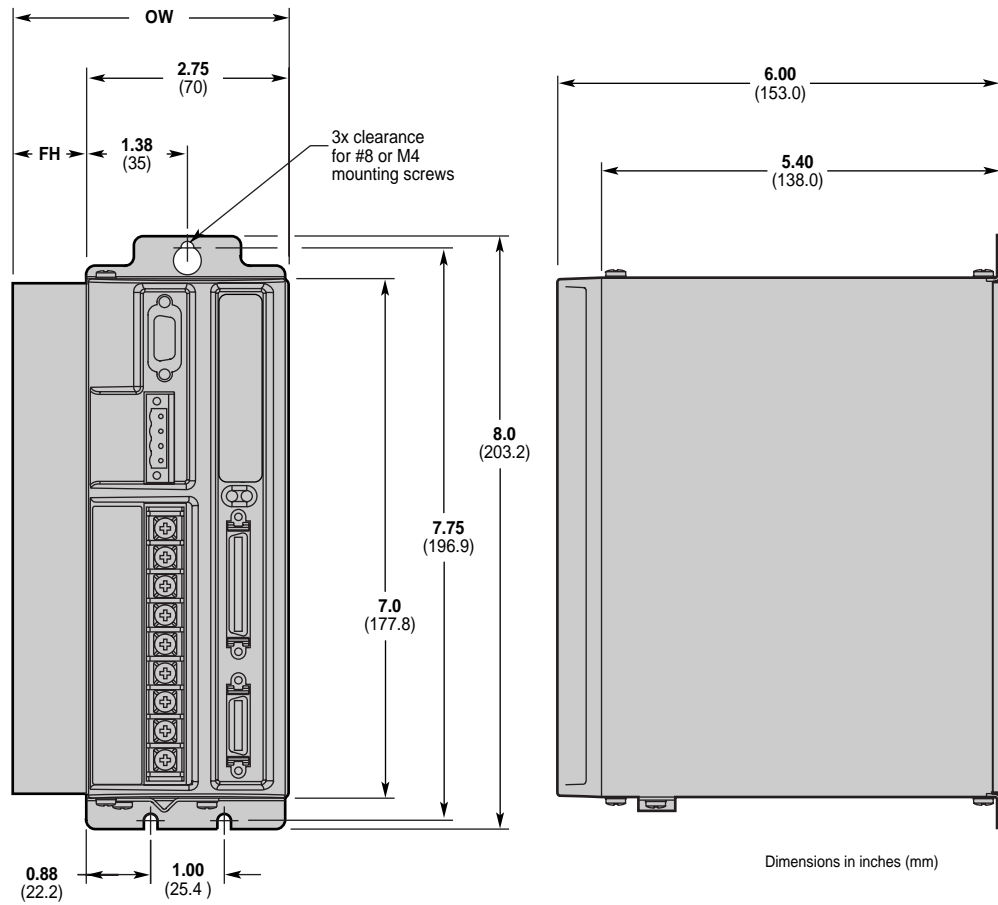

Product	OW Overall Width inches (mm)	FH Fin Height inches (mm)
GT-L5	3.13 (79.4)	0.38 (9.5)
GT-L8	3.75 (95.3)	1.00 (25.4)

Drive Dimensions (Shorter Enclosure)

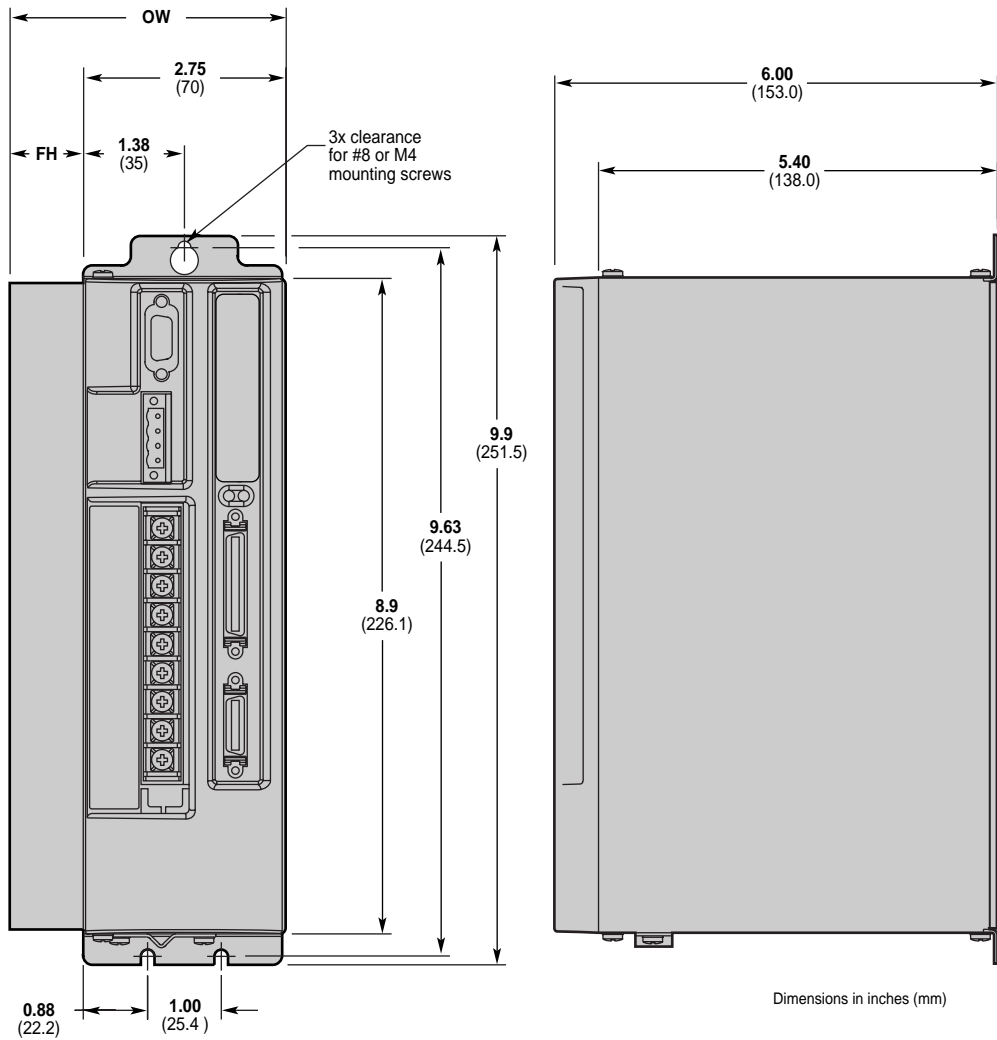

Product	OW Overall Width inches (mm)	FH Fin Height inches (mm)
GT-U5	3.13 (79.4)	0.38 (9.5)
GT-U8	3.75 (95.3)	1.00 (25.4)

Drive Dimensions (Taller Enclosure)

Drive Mounting

The Gemini drive is a vented product. Mount it under an overhang to prevent material spilling into the drive.

Panel Layout Dimensions

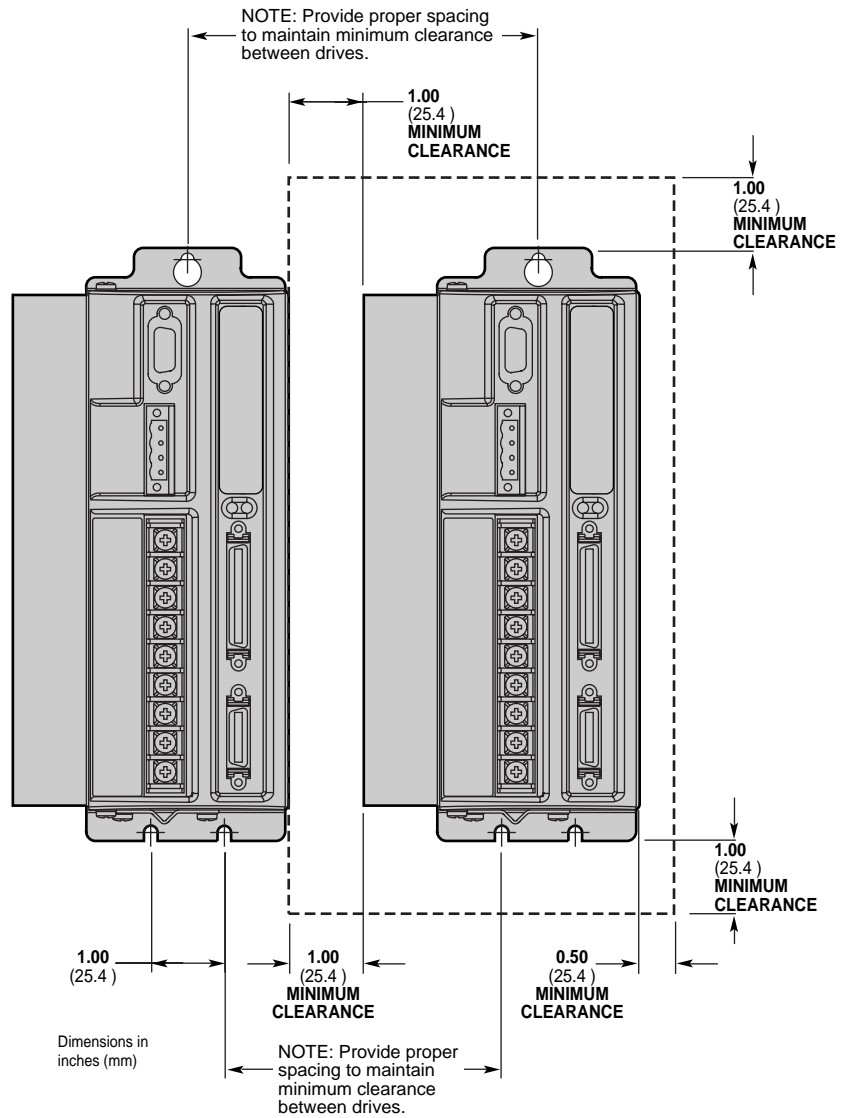

Panel Layout Dimensions

Protective Circuits

Short Circuit Protection

The Gemini drive has an internal circuit that protects it from short circuits between one motor terminal to another (phase to phase), or from any motor terminal to earth. A short circuit fault is a latched fault.

Causes of Fault:	Phase to phase short circuit Phase to earth short circuit
Results of Fault:	Power to motor is turned OFF LEDs: Left = illuminated RED; Right = off Fault output is activated Latched fault

Inrush Current Protection

The Gemini drive has internal circuitry that protects it from high inrush current when power is initially applied to the drive. The circuitry works automatically.

Drive	Inrush Current Limiter (ohms):	Current limiter bypassed with shorting relay:
GT-L5	5Ω	yes
GT-L8	5Ω	yes
GT-U5	5Ω	no
GT-U8	5Ω	no

GT-L5/8 drives have a shorting relay that removes the inrush current limiter after drive startup. This allows maximum bus voltage in high acceleration/peak torque/maximum speed applications.

Operation is temperature dependent:

Ambient Temperature:	Inrush Current Limit:
25°C (77°F)	less than 35 amps
50°C (122°F)	less than 70 amps

Drive Overtemperature Protection

The drive overtemperature circuit monitors the drive's internal temperature sensors. If the sensors exceed the threshold temperature, the drive issues an overtemperature fault.

Threshold Temperature:	80°C (176°F)
Results of Fault:	Power to motor is turned OFF LEDs: Left = illuminated RED; Right = off Fault output is activated Latched fault

Undervoltage Protection

The Gemini drive's undervoltage protection circuit monitors AC input voltage. If input voltage falls below 75VAC while the drive is operating, the drive issues an undervoltage fault, and turns off power to the motor.

Undervoltage protection has the following features:

Threshold Voltage:	Voltage falling below 75VAC trips fault
Results of Fault:	Power to motor is turned OFF
	LEDs: Left = illuminated RED; Right = off
	Fault output is activated
	Latched fault

Regeneration Protection

The Gemini drive's regeneration circuit protects it from *regenerated* energy—excess energy from the load during deceleration.

NOTE: Regeneration for an extended period of time can cause a regeneration fault.

Regeneration Protection Specifications

Drive	Continuous Dissipation (watts):	Activation Conditions:
GT-L5	24W	Turn on at 215VDC; turn off at 208VDC
GT-L8	24W	Turn on at 215VDC; turn off at 208VDC
GT-U5	10W	Turn on at 92VDC; turn off at 83VDC
GT-U8	10W	Turn on at 92VDC; turn off at 83VDC
Results of Fault:		Power to motor is turned OFF
		LEDs: Left = illuminated RED; Right = off
		Fault output is activated
		Latched fault

Cable Specifications

This section contains specifications for Compumotor cables and cabling accessories you can use with Gemini drives.

CE Cables

Many Compumotor cables are *CE Cables*. If installed according to instructions in *Appendix C Regulatory Compliance: UL and CE*, these cables are designed to aid the user in gaining European Compliance, and are thus an integral part of a CE system solution. CE cables add RF screening and bonding to reduce emissions, and provide high integrity safety Earth bonding. They also help to reduce problems in high electrical noise environments.

Step and Direction Command Cable

If you operate the drive in step and direction mode, use this cable to connect the Gemini drive to a Compumotor 6K controller.

Part Number: 71-016966-10
 CE Cable: Yes, if installed according to instructions in *Appendix C*

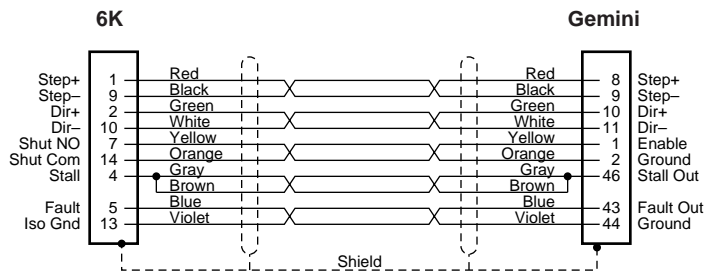

Cable – Step and Direction – Color Code

Gemini 50 Pin Connector to Flying Leads Cable

Use this cable to connect the Gemini drive's 50 pin connector to a Compumotor 6200, AT6n00, or non-Compumotor indexers/controllers.

Part Number: 71-016943-10
 CE Cable: Yes, if installed according to instructions in *Appendix C*

Compumotor 6200, AT6n00 Connections

The next drawing shows connections to a Compumotor 6200 or AT6n00 indexer.

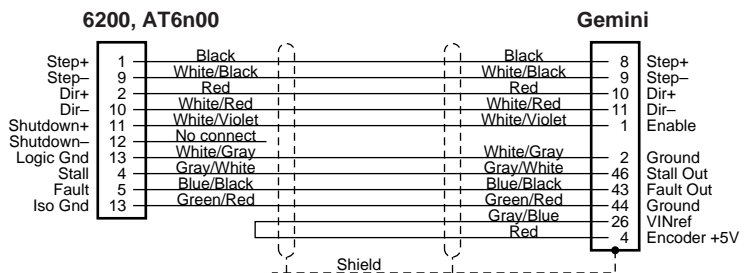

Cable – Flying Leads – 6200 Connections

NOTE: If using Compumotor 6000 Series stepper products, connect Gemini VINref (pin 26) to +5VDC, such as Gemini ENCODER +5 (pin 4 or 5). Do not connect Gemini VINref to any voltage higher than +5VDC.

Flying Lead Cable – Color Code

The next drawing shows the color code for the 50 pin connector/flying lead cable.

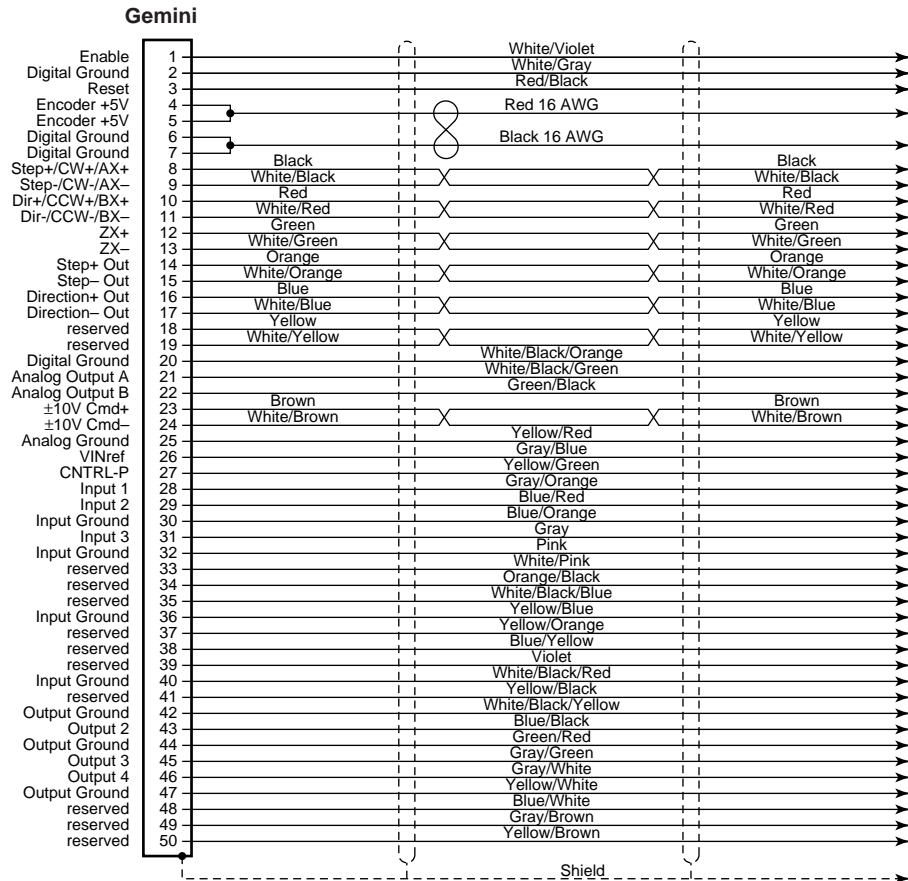

Cable – Flying Leads

Gemini 50 Pin Connector to 50 Pin D-Connector Cable

Use this cable to connect the Gemini drive's 50 pin DRIVE I/O connector to the 50 pin D-connector on the Gemini 50 pin breakout module (GEM-VM50).

Part Number: 71-016945-03

CE Cable: Yes, if installed according to instructions in *Appendix C*

This cable has the same pinout and color code as the flying lead cable; instead of flying leads, it has a 50 pin D-connector on the end.

Gemini GEM-VM50 – 50 Pin Breakout Module

Use the 50 pin breakout module for access to individual terminals on the 50 pin DRIVE I/O connector. The GEM-VM50 includes the cable above.

Description:	Part Number:
50 pin Breakout Module (with Cable)	GEM-VM50
50 pin Breakout Module (without cable)	01-016986-01

Null Modem Cable – 9 Pin D-Connector to 9 Pin D-Connector

Use this cable for RS-232 communications between the Gemini drive and a terminal. Note that this is not a “straight-through” cable; pins 2 and 3 are crossed, making it a “null-modem” cable.

Part Number:	71-016939-10
CE Cable:	Yes, if installed according to instructions in <i>Appendix C</i>
Connector:	9 pin female D-subminiature connector on each end

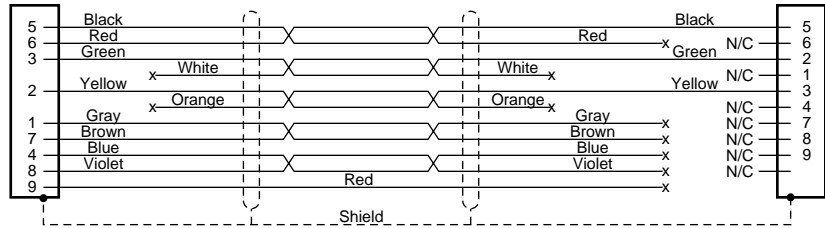

Cable – RS-232 Null Modem

Gemini GC-50 – 50 Pin Connector

The Gemini GC-50 is a 50 pin breakout module that connects directly to the 50 pin DRIVE I/O connector. Dimensions are shown below.



Connect wires to the GC-50 *before* installing it in the Gemini drive. This will avoid damage that may be caused by wiring the GC-50 while it is attached to the drive.

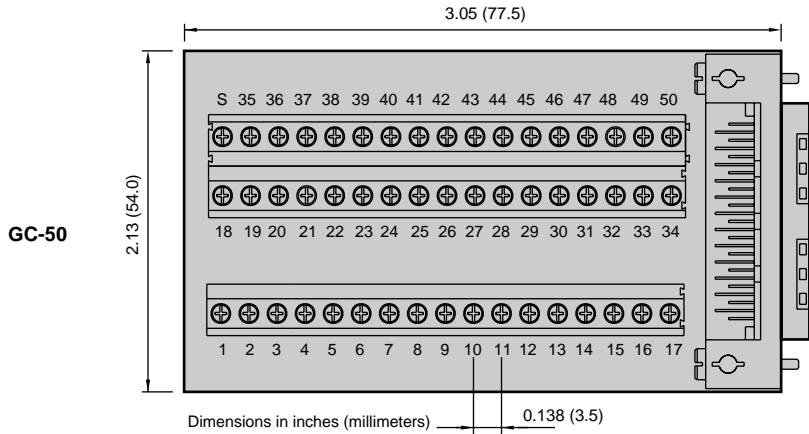

GC-50 Dimensions

