

APPENDIX B

# Using Non-Compumotor Motors

---

## IN THIS CHAPTER

---

- Commands for Motor Configuration
  - Motor Requirements
-

## Using Non-Compumotor Motors

---

If you use a non-Compumotor motor, you must configure the drive for your motor by setting values for all commands in the following table. Also see the *Motor Parameters* table on the *Motion Planner CD-ROM* for examples of recommended drive configuration settings for Compumotor motors.

### Commands for Motor Configuration

| Command: | Description:  |
|----------|---|
| ERES     | encoder feedback resolution; counts per revolution, post-quadrature |
| DMTIC    | continuous current; amps – rms, 40°C (104°F)                        |
| DMTICD   | continuous current derating; percent                                |
| DMTKE    | voltage constant; V/krpm  |
| DMTRES   | line-to-line resistance; at 25°C (77°F)                             |
| DMTJ     | rotor inertia; kg-m <sup>2</sup> *10 <sup>-6</sup>                  |
| DPOLE    | number of pole pairs  |
| DMTW     | rated speed; revolutions per second                                 |
| DMTIP    | peak current; amps rms  |
| DMTLMN   | minimum line-to-line inductance; mH                                 |
| DMTLMX   | maximum line-to-line inductance; mH                                 |
| DMTD     | motor damping; nM/rad/sec   |
| DMTRWC   | winding to case thermal resistance; °C/watt                         |
| DMTTCM   | motor case thermal time constant; minutes                           |
| DMTTCW   | motor winding thermal time constant; minutes                        |
| DPWM     | PWM switching frequency   |
| DMTMAX   | motor maximum temperature   |

Use Motion Planner or Pocket Motion Planner to enter these command settings into the drive's memory. See the *Gemini Programmer's Reference* for more information on commands.

## Motor Requirements

If you have questions about using a non-Compumotor motor with a Gemini drive, call Technical Support (see phone numbers on the inside cover of this manual).

## Hall Sensor Configuration/Troubleshooting

---

This section will assist you in resolving a Hall fault (TASX Bit 21). Several problems can cause a Hall fault. The following list will help identify these problems.

### Troubleshooting Checklist:

1. Does THALL report back either 0 or 7?  
**IF YES:** see Problem #1 or #2, below.
2. Does THALL change if you move the motor by hand?  
**IF NOT:** see Problem #2, below.
3. Does THALL have six distinct Hall states from 1 to 6? (No numerical order is necessary.)  
**IF NOT:** see Problem #2, below.
4. As reported by THALL, are there  $n$  times 6 Hall states as the rotor turns one revolution, where  $n$  is equal to the number of pole-pairs. (Linear motors:  $n = \text{pitch}$ )  
**IF NOT:** see Problem #2 or #3, below.

5. As reported by THALL, is the Hall state sequence [1, 5, 4, 6, 2, 3, 1 ... ] as the motor turns clockwise? (Clockwise means TPE is increasing; it is also the direction the motor turns in DMODE13.)  
**IF NOT:** see Problem #4, below.
6. Does TASX report a Hall fault each time the drive is enabled (DRIVE1), even though the Hall state sequence is correct?  
**IF YES:** see Problem #4, below.
7. Is the Hall fault intermittent? (Intermittent means the fault does not occur every revolution.)  
**IF YES:** see Problem #5, below.

**Possible Problems:**



- #1: No Hall states are seen by the drive.
- #2: Cable is not connected, or is connected incorrectly (miswired).
- #3: DPOLE or DMEPIT is not set correctly.
- #4: Either the motor wires or the Hall wires are connected incorrectly.
  - Use Procedure I to fix this problem by changing the motor wires.
  - Use Procedure II to fix this problem by changing the Hall wires.
- #5: The Hall wires or the encoder wires may have loose connections, causing intermittent faults.

**Procedure I:**

Use this procedure to connect your **motor wires** to the GV drive.

1. Randomly connect two motor wires and slowly apply a positive voltage with respect to the third. See the next drawing.

---

**WARNING**

This procedure could damage the motor. Slowly increase the voltage until the motor moves. Do not exceed the rated current.

---

2. If THALL reports back a 1, 2 or 4, change SHALL from either 0 to 1 or from 1 to 0. After you change SHALL, reset the drive.
3. Repeat step 1 until THALL reports a value of 6.
4. The wire which is on the negative voltage or ground is motor wire W. The two wires at the positive voltage are U and V.
5. Now there are two possibilities:
  - 5.1. Connect the motor wires to the terminals. Operate the drive in DMODE13. If the motor does not turn in the clockwise direction, exchange motor wires U and V.
  - 5.2. Put positive voltage on motor wire W together with either U or V and put negative voltage or ground on the remaining wire. If THALL reports a value of 3, the wire at the negative voltage is V. If THALL reports a value of 5, the wire at the negative voltage is U.

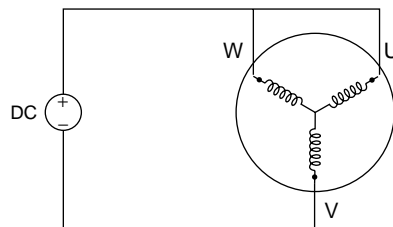

*Connection Diagram*

**Procedure II:**

Use this procedure to connect your **Hall wires** to the GV drive.

1. First operate the drive in DMODE13 and verify that the motor turns clockwise. If not, swap any two motor wires.

- Connect motor wires U and V and slowly apply a positive voltage with respect to W. See the previous drawing.

---

**⚠ WARNING ⚠**

This procedure could damage the motor. Slowly increase the voltage until the motor moves. Do not exceed the rated current.

---

- If THALL reports a value of 1, 2 or 4, change SHALL from either 0 to 1 or from 1 to 0. After you change SHALL, reset the drive.
- Change the Hall wires until THALL reports a value of 6.
- Connect motor wires U and W and slowly apply a positive voltage with respect to V.
- If THALL does not report a value of 3, change Hall wires B and C.  
If THALL reports a value of 3, the wires are connected correctly.

The following table summarizes phase voltages and their corresponding Hall states. Starting with SHALL0 and the phase voltages as shown, the THALL command should report the Hall states that match the “Correct” column. If instead THALL reports Hall states that match the “Use SHALL1” column, enter SHALL1 and reset the drive. The Hall states should now match the “Correct” column.

| Phase |   |   | Hall State |            |
|-------|---|---|------------|------------|
| U     | V | W | Correct    | Use SHALL1 |
| -     | - | + | 1          | 6          |
| -     | + | + | 5          | 2          |
| -     | + | - | 4          | 3          |
| +     | + | - | 6          | 1          |
| +     | - | - | 2          | 5          |
| +     | - | + | 3          | 4          |

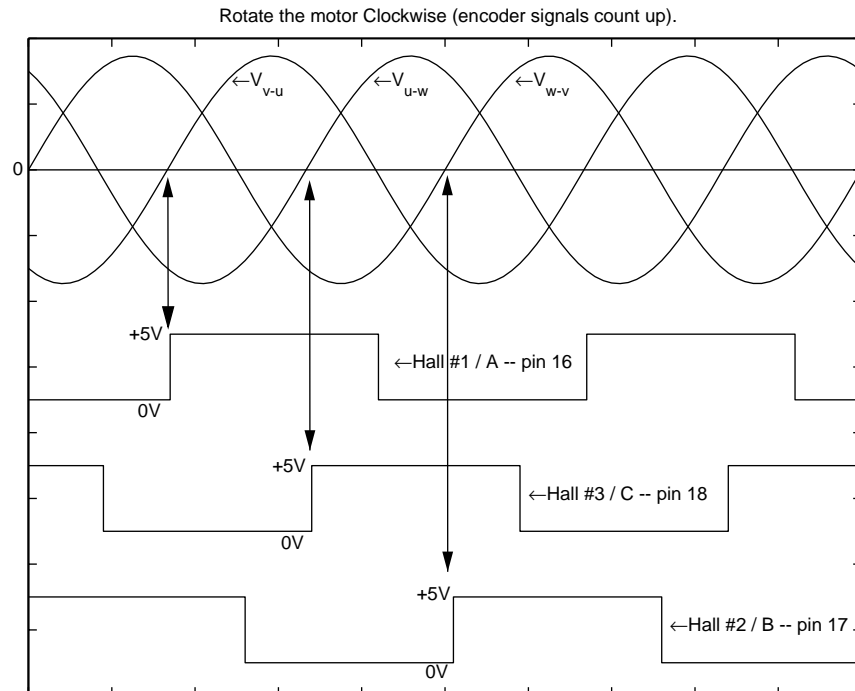

*Motor Terminal Voltages (back EMF) and Hall Sensor Signals*