

CHAPTER FOUR

Special Features

IN THIS CHAPTER

- Relay
 - +24VDC Keep Alive Power Connections
 - Multiple Drive Installations
 - V BUS±
 - Regeneration Protection and the GPDM
 - Aligning the Resolver
 - RS-232/485 Communications
 - Updating the Drive's Operating System
-

Relay Connections (optional)

To use the drive's internal relay, connect your external circuit to the RELAY COM and RELAY N.O. terminals. The next drawing shows a typical application—connecting a motor brake to the relay terminals.

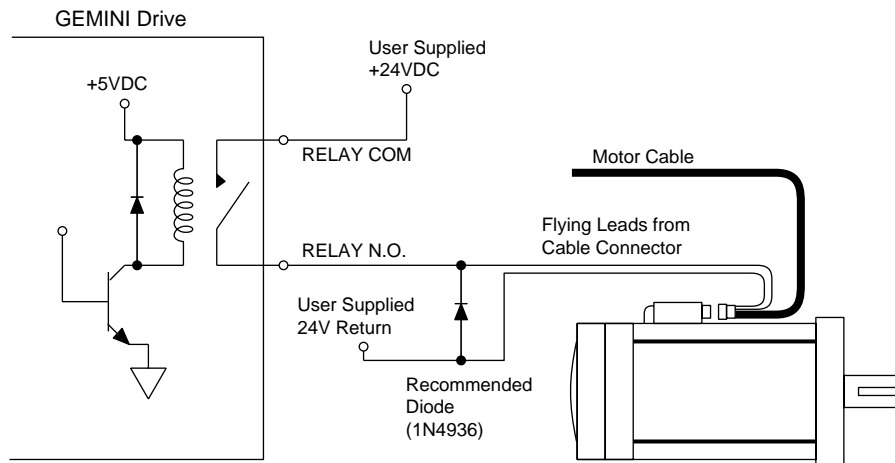

Relay Connections

The relay is normally open. When the drive is enabled, it holds the relay closed. If the drive faults or is disabled, the relay will open.

Relay Operation:

Drive Condition:

Enabled
 Faulted
 No AC power*, or not enabled

Relay State:

Closed
 Open
 Open

* +24VDC power does not affect the relay. With +24VDC applied, the relay will be open if AC power is *not* applied.

Relay Specifications:

Relay Type:

Dry contact mechanical relay
 Normally open

Relay Rating:

5 amps at 24VDC or 120VAC

+24VDC “Keep Alive” Power Connections (optional)

The following drawing shows how to connect an external +24VDC power source to the drive. Use the removable terminal connector that is supplied with the drive.

With +24VDC applied, the drive's internal control board will remain powered when the primary AC power source is disconnected, and will maintain several important functions, including communication diagnostics, position feedback, and other logic functions.

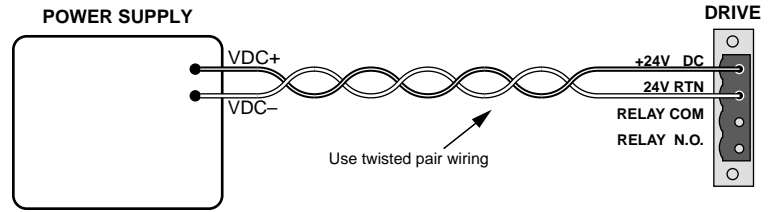

+24VDC Power Input

+24VDC Specifications:

Input voltage range:	19.2 – 28.8 VDC
Input current:	500 mA (minimum)
Functions powered under +24VDC:	position information (encoder or motor position counters in drive) communications diagnostics motor feedback program execution not involving motion (e.g., error programs, etc.)
Software status bit (see TASX command):	indicates “keep alive” is active: +24VDC power only (AC power is disconnected)

CAUTION

Do not exceed 28.8VDC input voltage

Multiple Drive Installations (optional)

Safety Earth Connections

For multiple drive installations, we recommend a single point or “star” safety earth configuration, as shown below.

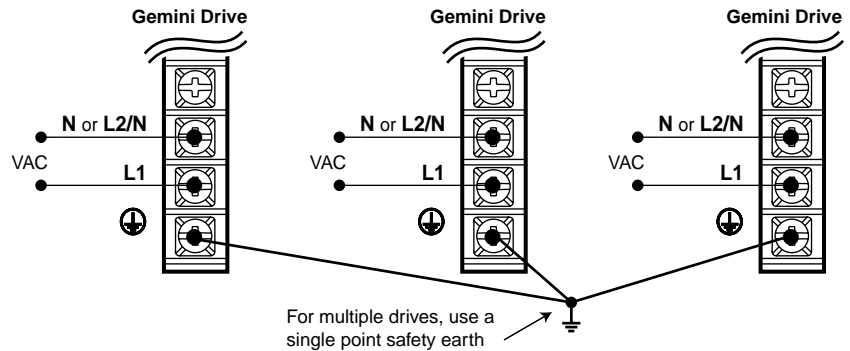

Multiple Drives: Single Point Safety Earth

Under normal operation, no current should flow through the safety earth connection.

Connecting V Bus±: Sharing the Power Bus (optional)

You can connect the power buses of Gemini GV-U3n/U6n/U12n/H40n drives in parallel, through the V BUS+ and V BUS- terminals. With the buses connected in parallel, regenerated energy from one drive will be used by the other drives. (Do *not* connect GV-H20n drives in parallel to each other or to other Gemini drives.)



WARNING



V BUS+ and V BUS- terminals are at hazardous voltages when power is applied to the drive, and for up to 30 seconds after power is removed. Lower voltages may still be present for several minutes after power is removed. Reinstall the clear plastic terminal cover after you make connections.



CAUTION



Connect together only V BUS± terminals of drives that share the same fused AC power source, as shown below.

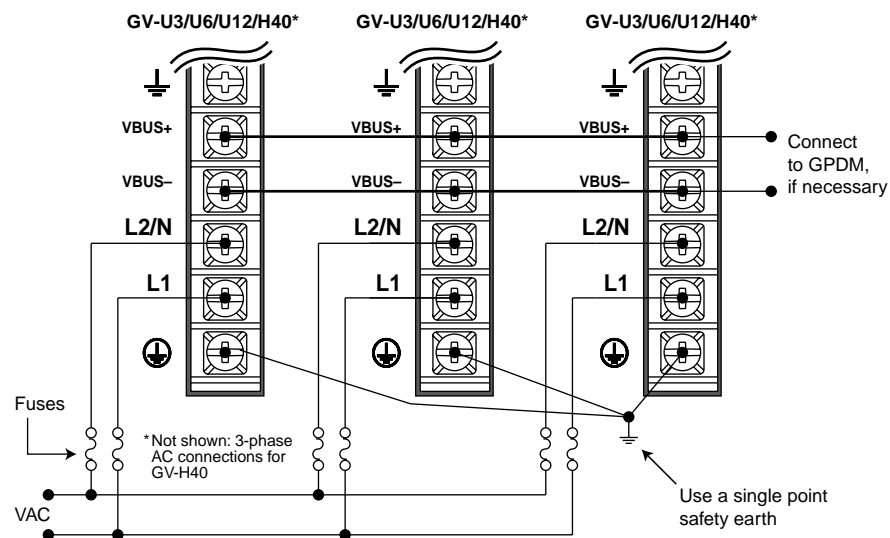

Sharing the Power Bus

If excess regenerated energy causes an overvoltage or regeneration fault, you can connect the Gemini Power Dissipation Module (GPDModule) to the drive's V BUS± terminals. See *Regeneration Protection* below for connection instructions and more information about the GPDModule.

NOTE: Because the Gemini drive has a current inrush limiter, we recommend that you do not add additional bus capacitance to V BUS+ and V BUS-.

Regeneration Protection

The following sections describe regeneration protection for Gemini drives, and the Gemini Power Dissipation Module.

Regeneration with GV-L3n/H20n/H40n

Gemini GV-L3n/H20n/H40n drives have internal circuitry to protect them from *regeneration*—energy from the load during deceleration. Excessive regeneration can cause either of two faults:

- Overvoltage Fault (see *Overvoltage Protection* in *Appendix A Specifications*)
- Regeneration Fault (if regeneration occurs for an extended period of time)

Specifications for regeneration protection are:

Drive	Dissipation (watts):	Maximum Pulse Energy	Activation Conditions	
			Turn on:	Turn off:
GV-L3n	8W continuous 500W peak	1.3 KJ	200VDC	193VDC
GV-H20n	25W continuous (100W continuous at 40°C) 6KW peak	6 KJ	396VDC	385VDC
GV-H40n	150W continuous 9KW peak	9 KJ	396VDC	385VD

Results of Fault: Latched fault; power to motor is turned OFF; fault output is activated
LEDs: Left = illuminated RED; Right = off

All temperatures in moving 50°C ambient air, unless otherwise noted.

Regeneration with GV-U3n/U6n/U12n

Gemini GV-U3n/U6n/U12n drives do not have internal regeneration circuitry. Consequently, they cannot cause a regeneration fault. The drives can absorb the following amounts of regenerated energy in their internal capacitors:

Drive	Absorb (joules):	
GV-U3n	44 J	(from 340 – 410VDC: 1680 μF)
GV-U6n/12n	59 J	(from 340 – 410VDC: 2240 μF)

If excess regenerated energy causes overvoltage faults, you can connect the Gemini Power Dissipation Module (GPDM) to the V BUS± terminals of these drives. Regenerated energy from the drive will then be dissipated in the GPDM.

Gemini Power Dissipation Module (GPDM)

The GPDM is designed for use with GV-U3n/U6n/U12n drives. (NOTE: If you use a GV-H20n/H40n drive, and regeneration in your application exceeds the dissipation capacity of the internal regeneration circuit (see above), you may connect a GPDM to dissipate the excess regenerated energy.)

The GPDM dissipates excess regenerated energy in its internal resistors. If regenerated energy from the motor causes the drive's DC bus voltage to increase to 398VDC, the GPDM connects its resistors in shunt across the DC bus. Energy in the drive's capacitors is then dissipated as heat in the GPDM's resistors.

When the DC bus voltage decreases to 380VDC, the GPDM disconnects its resistors. If the motor continues to regenerate energy and the bus again rises to 398VDC, the process repeats until regeneration stops or a fault occurs.

The GPDM monitors three parameters, and generates a fault if any of the following are exceeded:

- maximum duty cycle
- maximum temperature
- maximum energy pulse

If the GPDM faults, it will disconnect itself from the DC bus and illuminate its red LED. Its internal fan will continue blowing. The GPDM will automatically clear

the fault and reset itself within 10 seconds (an overtemperature fault may take longer to clear). When it resets itself, the GPDM will illuminate its green LED; the GPDM is then again ready to dissipate regenerated energy.

If regeneration continues while the GPDM is in a faulted state, the drive may experience an overvoltage fault. If you look for the cause of the drive overvoltage fault, be aware that it may have been caused by a prior GPDM fault—even though the left LED is now green.

If excessive regeneration continues to cause GPDM faults or drive faults, you can connect a second GPDM, as shown in the *GPDM Connections* drawing below.

GPDM Specifications

Activation Conditions:	Turn on: 398VDC Turn off: 380VDC
Resistance:	Six 100 ohm resistors in parallel (16.7 ohm equivalent)
Continuous Dissipation:	300W in 25°C internal ambient
Maximum Dissipation:	9KW
Maximum Pulse Energy:	13KJ (pulse rating of resistors, repeatable, not to exceed continuous rating)
Weight:	3.1 pounds (1.4 kg)

LED Color Code for GPDM:

Left:	Right:	Status:
Green	Off	ready
Green	Yellow*	active
Red	Off	fault (max. temperature, duty cycle, or pulse exceeded)

*Yellow LED may flash or be continuously illuminated until GPDM stops dissipating

GPDM Connection Instructions



WARNING



Sheet metal and exhaust air at the top of the enclosure are hot. Avoid contact.



WARNING



V BUS+ and V BUS- terminals are at hazardous voltages when power is applied to the drive, and for up to 30 seconds after power is removed. Lower voltages may still be present for several minutes after power is removed. Reinstall the clear plastic terminal cover after you make connections.



WARNING



Only connect V BUS± terminals of drives that share the same fused AC power source, as shown in the next drawing.

Connecting the GPDM

1. Connect up to three Gemini Servo Drives to one GPDM. (Connect only GV-U3n/U6n/U12n drives. Do not connect any other Gemini drives to the GPDM.)
2. Connect drive V BUS+ terminals to V BUS+ on the GPDM
3. Connect drive V BUS- terminals to V BUS- on the GPDM
4. For multiple drives, connect drive safety earth terminals to a single point ground.
5. Keep connections between drive and GPDM less than 12 inches (300 mm). Use 14 AWG (2.5 mm²) or greater diameter wire.

The next figure shows a typical installation.

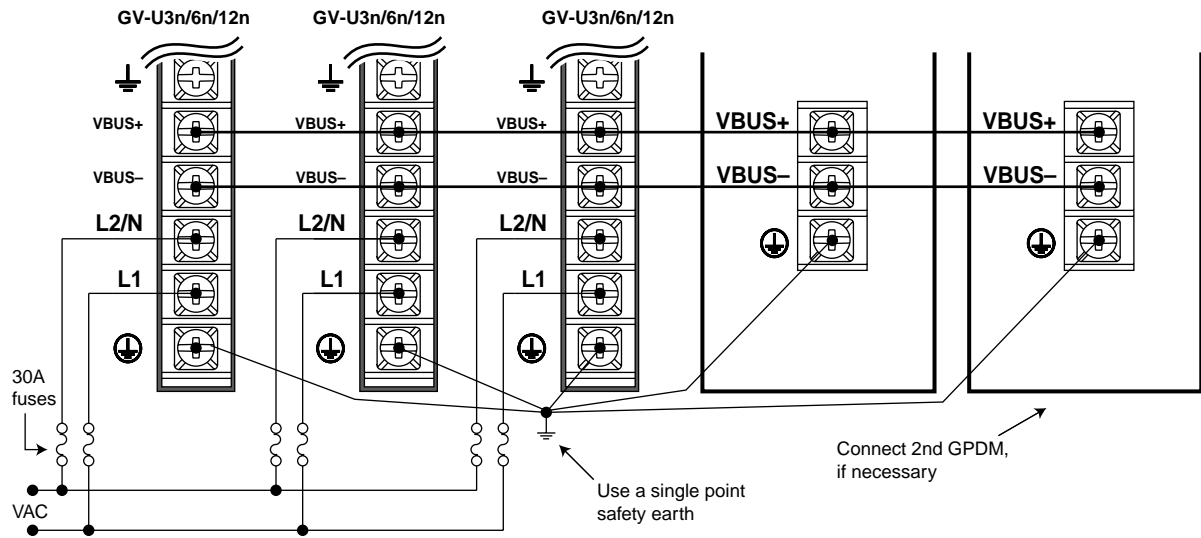

GPDM Connections

The next figure shows GPDM dimensions.

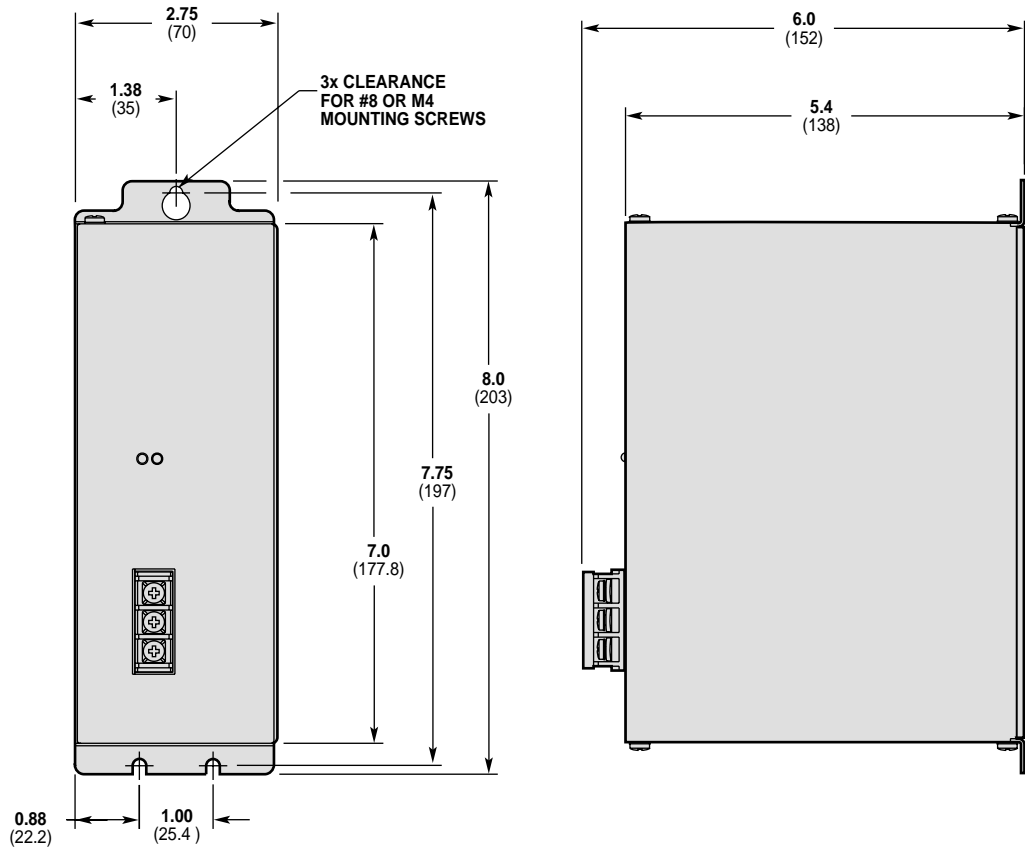

Dimensions – GPDM Power Dissipation Module

Aligning the Resolver (optional)

Resolvers on Compumotor motors are aligned at the factory. Ordinarily, no further alignment is required. However, you may wish to align the resolver if you suspect the resolver is misaligned, or if you are using a non-Compumotor motor.

A Note About Resolver Speed

Resolver speed describes the relationship between resolver *electrical* revolutions and shaft *mechanical* revolutions. For example, if one resolver electrical revolution is equal to one shaft mechanical revolution, the resolver is a “single speed” or “one speed” resolver. If two electrical revolutions equal one mechanical revolution, the resolver is a “two speed” resolver.

The following alignment procedures assume you have configured the drive with an accurate resolver speed value. For Compumotor motors, resolver speed is loaded from the motor configuration file.

Resolver Alignment Procedures

There are three methods to align the resolver:

- Method 1 – Enter a known resolver offset angle.
- Method 2 – Find an unknown resolver offset angle, and store it in the drive's nonvolatile memory.
- Method 3 – Loosen the resolver cleats and rotate the housing while monitoring offset angle. Secure the housing when the angle is zero degrees.

Details for these methods are given below.

Method 1 – Entering a Known Offset Angle

1. Disconnect the load from the motor shaft. The shaft should be free to rotate.
2. Issue an SRSET command; include the desired offset angle. For example, entering SRSET10 automatically sets the offset angle to 10 degrees.



WARNING



The SRSET command takes effect immediately. If you set the offset angle incorrectly the system may become unstable.

3. Disable the drive. Upon being disabled, the drive stores the value for the offset angle into nonvolatile memory. It uses this value for all future operations. You do not need to perform this procedure again.

Method 2 – Finding an Unknown Offset Angle

Use this method if you do not know your resolver's offset angle.

1. Disconnect the load from the motor shaft. The shaft should be free to rotate.
2. Verify correct motor wiring. See the *Gemini Motor Reference Manual* for wiring information for Compumotor motors.
3. Configure the drive for your motor, as described in *Chapter 2 Installation*. If you use a non-Compumotor motor, create and download a motor configuration file for your motor.
4. Enable the drive.
5. Issue a DMODE13 command to put the drive into autorun mode. The motor should begin turning clockwise at approximately 1 rps, as viewed from the shaft end of the motor. If the motor turns in the wrong direction or at the wrong speed, check the motor wiring, and verify correct motor pole configuration (DPOLE command).
6. Issue a DMODE11 command to put the drive into alignment mode. The motor will stop turning.
7. Issue an SRSET command. The motor may turn as much as 1/2 revolution. It will stop when the motor magnetic poles align.
8. Disable the drive. Upon being disabled, the drive stores the value for the offset angle into nonvolatile memory. It uses this value for all future operations. You do not need to perform this procedure again.
9. Return the drive to the appropriate mode of operation (DMODE command).

Method 3 – Rotating the Resolver Housing

Use this method to manually rotate the resolver to a specific offset angle (usually zero degrees).

1. Disconnect the load from the motor shaft. The shaft should be free to rotate.
2. Verify correct motor wiring. See the *Gemini Motor Reference Manual* for wiring information for Compumotor motors.
3. Configure the drive for your motor, as described in *Chapter 2 Installation*. If you use a non-Compumotor motor, create and download a motor configuration file for your motor.
4. Enable the drive.
5. Issue a DMODE13 command to put the drive into autorun mode. The motor should begin turning clockwise at approximately 1 rps, as viewed from the shaft end of the motor. If the motor turns in the wrong direction or at the wrong speed, check the motor wiring, and verify correct motor pole configuration (DPOLE command).
6. Issue a DMODE11 command to put the drive into alignment mode. The motor will stop turning.
7. Issue an SRSET command. The motor may turn as much as 1/2 revolution. It will stop when the motor magnetic poles align.
8. Loosen the cleats that hold the resolver housing onto the motor.
9. Issue a TSROFF command repeatedly as you slowly turn the resolver housing. The TSROFF command indicates the present resolver offset angle.
10. Turn the resolver housing until the offset angle is zero degrees (or until you obtain your desired offset angle).
11. Tighten the cleats.
12. Disable the drive. Upon being disabled, the drive stores the value for the offset angle into nonvolatile memory. It uses this value for all future operations. You do not need to perform this procedure again.
13. Return the drive to the appropriate mode of operation (DMODE command).

RS-232/485 Communications

The Gemini drive has a single serial port marked, “RS-232/485,” on the front of the unit. In the following this port will be referred to as the COM port. The Gemini drive uses a binary language for communication; it does not use ASCII. To enable 6000 ASCII level communication in a terminal mode, the Gemini uses a translator utility in Pocket Motion Planner and in the CommServer (for use with Motion Planner). In all other ways, the serial communication functions in the Gemini behave like other Compumotor products. Gemini drives can be connected together in RS-232 Daisy Chains and RS-485 Multi-Drop configurations.

In this section:

- Establishing Communications
- Configuring the serial port
- RS-232 Communications
- RS-232 Daisy Chaining
- RS-485 Communications
- RS-485 Multi-Drop

Establishing Communications

The drive’s configuration port is a 9 pin D-connector. You can use it for either RS-232 or four wire RS-485 communications, as shown in the next drawing.

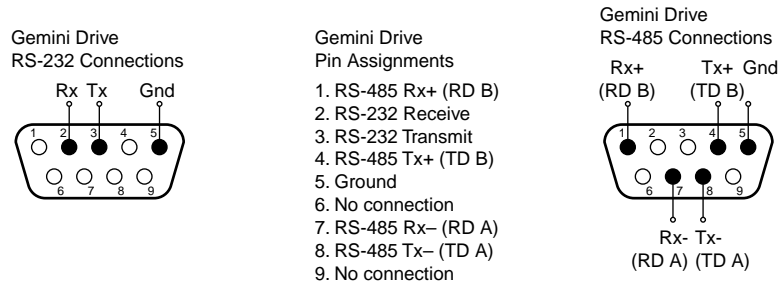

RS-232/485 Connections

To communicate with the drive, connect the drive’s RS-232/485 connector to a PC running Motion Planner, or to a palm PC running Pocket Motion Planner with Windows CE. Verify your computer’s connector pinout; you may need to use a “null modem” cable to connect your computer’s transmit terminal to the Gemini’s receive terminal, your computer’s receive terminal to the Gemini’s transmit terminal, and your computer’s ground terminal to the Gemini’s ground terminal.

Configuring the Serial Port

The following commands can be used to configure the Gemini serial port and the terminals used by Motion Planner and Pocket Motion Planner. Complete descriptions of these commands can be found in the *Gemini Programmer's Reference*.

E	Enable Serial Communication
ECHO	Enable Communication Echo
BOT	Beginning of Transmission Characters
EOT	End of Transmission Characters

EOL End of Line Terminating Characters
 ERRBAD Error Prompt
 ERRLVL Error Detection Level
 ERROK Good Prompt

- The baud rate for the Gemini is set at 9600. Future releases of Gemini firmware will offer additional baud rate choices. Check the Compumotor web site (www.compumotor.com) for information on new software releases.
- The Gemini serial port contains connections for both RS-232 and RS-485 communication. The Gemini drive will automatically switch between RS-232 and RS-485 mode depending on which connections in the port's 9 pin D-connector are active. See wiring diagrams.
- Some RS-232 cables use hardware handshake signals that are used by the RS-485 pins. The RS-485 interface will automatically disable itself if this is detected. If this occurs, you must reset the drive to re-enable the RS-485 interface.

RS-232 Communications

Pin Out for RS-232 Communication:

Pin Description

- 2 Rx (receive). Connect to Tx on your computer.
- 3 Tx (transmit). Connect to Rx on your computer.
- 5 GND (logic ground). Connect to GND on your computer

- Maximum RS-232 cable length is 50 feet (15.25 meters)
- To establish unique addresses for daisy-chained units, use the ADDR command.

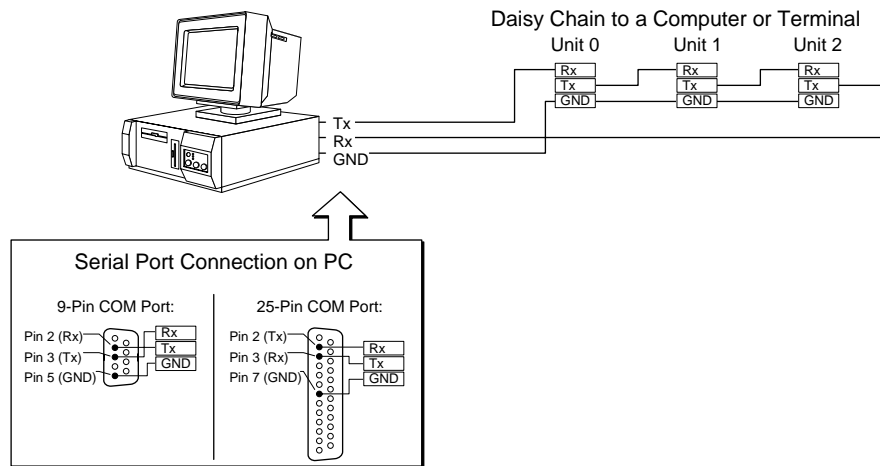

RS-232 Daisy Chain Connections

RS-232 Daisy-Chaining

Up to ninety-nine stand-alone Gemini drive products may be daisy-chained. Refer to the wiring diagrams for daisy-chain connections.

Follow these steps to implement daisy-chaining:

Step 1

Connect the daisy-chain with a terminal as the master. (See the previous drawing.)

To enable and disable communications on a particular drive unit in the chain, you must use the Daisy-Chain Address (ADDR) command to establish a unique device

address for each unit. The ADDR command automatically configures unit addresses for daisy chaining. This command allows up to 99 units on a daisy chain to be uniquely addressed.

Sending ADDR i to the first unit in the daisy chain sets its address to be (i). The first unit in turn transmits ADDR($i + 1$) to the next unit to set its address to ($i + 1$). This continues down the daisy chain until the last unit of (n) daisy-chained units has its address set to ($i + n$).

Note that a drive with the default device address of zero (0) will send an initial power-up start message similar to the following:

```
*TREV-GV-L3E_D1.0_F1.0
```

Step 2

To allow daisy chaining you must turn on echo mode for each drive on the chain (ECHO1). The ADDR command automatically leaves each device in echo mode after the device address is set when in RS-232 mode.

In the Gemini, daisy chaining can work in all error levels except error level 0 (see ERRLVL command). To set the drive error levels to your preferred state you can address each drive individually or send a global command. Note the address syntax used to send data to particular units:

Commands:

```
1_ERRLVL4      ; Set error level to 4 for unit #1
2_ERRLVL4      ; Set error level to 4 for unit #2
ERRLVL4        ; Set error level to 4 for all units on the chain
```

Unlike ASCII-based products, the binary prompts associated with the different error levels can pass through the daisy chain to the terminal controller without interfering with the other drives. At that point they are translated into the text strings defined by the ERROK and ERBAD commands. Consequently, error levels using prompts can be used in Gemini daisy chains.

To receive data from a particular drive on the chain, you must prefix the command with the appropriate unit's device address and an underline:

Commands:

```
1_ERES          ; Request encoder resolution from unit #1
*ERES4000       ; Response from unit #1
```

Use the E command to enable/disable RS-232 communications for an individual unit. If all drive units on the daisy chain are enabled, commands without a device address identifier will be executed by all units. Because of the daisy-chain's serial nature, the commands will be executed approximately 1 ms per character later on each successive unit in the chain (assuming 9600 baud).

Units with RS-232 disabled (EØ) will not respond to any commands, except E1; however, characters are still echoed to the next device in the daisy chain.

Commands:

```
3_E0            ; Disable RS-232 on unit #3
ERES2000        ; Set encoder resolution to 2000 on all other units
3_E1            ; Enable RS-232 on unit #3
3_ERES4000      ; Set encoder resolution to 4000 on unit #3
```

Verify communication to all units by using the techniques described above.

Step 3

Now that you have verified that the daisy chain is set up properly, you can use the various Pocket Motion Planner and Motion Planner tools to configure and monitor all units on the daisy chain.

RS-485 Communications

Pin Out for 4-Wire RS-485 Communications:

Pin	Description
1	Rx+ (also called RD B)
4	Tx+ (also called TD B)
5	GND (logic ground)
7	Rx- (also called RD A)
8	Tx- (also called TD A)

- Maximum RS-485 cable length is 4000 feet (1220 meters).
 - To establish unique addresses for multi-drop units, use the ADDR command.
 - Keep wires as short as possible. Termination resistors may be required on long cable runs.
 - Connect RS-485 cables before applying power to the drive.
- (Reconnecting the cables with power applied may cause the drive to interpret intermittent connections as RS-232 hardware handshake signals; this may result in shutdown of the RS-485 interface. If this happens, reset the drive to re-enable the RS-485 interface.)
- Recommended cable: Belden 9842.
 - Refer to the diagram below for connection information.

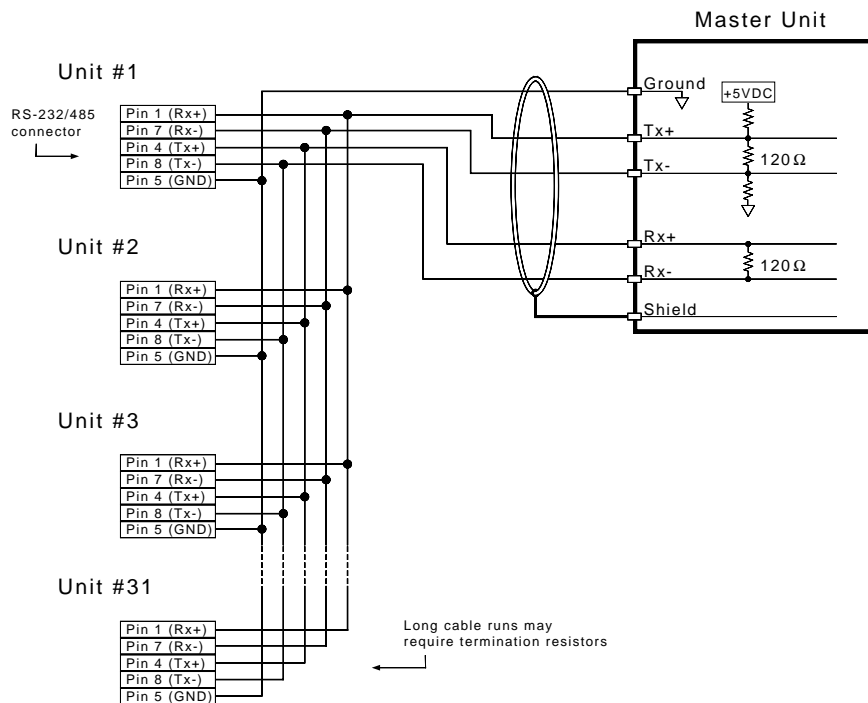

RS-485 Multi-drop Connections

RS-485 Multi-Drop

Up to 99 Gemini drives may be multi-dropped. (See the previous drawing.)

The ADDR command allows you to establish up to 99 unique addresses. To use

the ADDR command, you must address each unit individually before it is connected on the multi drop. For example, given that each product is shipped configured with address zero, you could set up a 4-unit multi-drop with the commands below, and then connect them in a multi drop:

1. Connect the unit that is to be unit #1 and transmit the \emptyset_ADDR1 command to it.
2. Connect the unit that is to be unit #2 and transmit the \emptyset_ADDR2 command to it.
3. Connect the unit that is to be unit #3 and transmit the \emptyset_ADDR3 command to it.
4. Connect the unit that is to be unit #4 and transmit the \emptyset_ADDR4 command to it.

If you need to replace a unit in the multi drop, send the \emptyset_ADDRi command to it, where “i” is the address you wish the new unit to have. For RS-485 multi-drop to work properly, each drive must have echo mode turned off (ECHO \emptyset).

In order to prevent the collision of prompts being transmitted simultaneously from several drives in response to a global command, you must configure the drives for either error level 2 or error level 0 in multi-drop mode. This can be done as follows:

Commands:

```
1_ERRLVL2      ; Set error level to 2 for unit #1
2_ERRLVL2      ; Set error level to 2 for unit #2
3_ERRLVL2      ; Set error level to 2 for unit #3
```

In general, to send a Gemini command from the master unit to a specific unit in the multi-drop, prefix the command with the unit address and an underscore (e.g., 3_ERES4000 sets the encoder resolution to 4000 on unit #3). The master unit may receive data from a multi-drop unit. You should now verify that you can access each unit on the multi-drop.

Now that you have verified that the multi-drop is set up properly, you can use the various Pocket Motion Planner and Motion Planner tools to configure and monitor all units on the multi-drop.

Updating the Drive's Operating System

The Gemini drive runs under an internal software operating system (firmware). The operating system was loaded into your drive during the manufacturing process, and under ordinary circumstances you will not need to update your drive's operating system. However, because Compumotor continues to add enhancements, you may want to upgrade the operating system. You may obtain a new operating system file from the Compumotor web site, or from Technical Support (see phone numbers on the inside cover of this manual).

For more information about web site downloads and update procedures, see the *Gemini Programmer's Reference*.