

APPENDIX A

Specifications

IN THIS CHAPTER

- Gemini Drive Specifications
 - Input/Output Specifications
 - Dimensions
 - Protective Circuits
 - Cable Specifications
-

Power Specifications

+24VDC Input Power (Optional “Keep Alive” Power)

Input voltage range: 19.2 – 28.8 VDC
 Input current: 500 mA (minimum)

AC Input Power

AC

| Drive | AC Input Voltage |
|---------|---|
| GV-L3n | 95VAC – 132VAC, 1-phase, 50/60 Hz |
| GV-U3n | 95VAC – 264VAC, 1-phase, 50/60 Hz |
| GV-U6n | 95VAC – 264VAC, 1-phase, 50/60 Hz |
| GV-U12n | 95VAC – 264VAC, 1-phase, 50/60 Hz |
| GV-H20n | 165VAC – 264VAC, 1-phase or 3-phase, 50/60 Hz |
| GV-H40n | 165VAC – 264VAC, 3-phase, 50/60 Hz |



CAUTION



Do not operate GV-L3 above 132VAC, or the drive will be permanently damaged.

| Connector: | GV-L3/U3/U6/U12/H20: | GV-H40n: |
|--------------------|--------------------------------|---------------------------------------|
| Drive terminals: | #8 (M4) screw terminals | #10 (M5) screw terminals |
| Mating terminals: | spade fork, 0.325" max. width | ring terminal, 0.25" I.D., 0.50" O.D. |
| Tightening torque: | 20 in-lbs nom., 24 in-lbs max. | 20 in-lbs nom., 24 in-lbs max. |

Output Power

| Drive | Continuous Output: | | Peak Output: | |
|---------|-------------------------|--------------------|--------------------------|--------------------|
| | Current (amps, peak) | Power (watts, max) | Current (amps, peak) | Power (watts, max) |
| GV-L3n | 3A | 440W | 7.5A | 1.1 kW |
| GV-U3n | 3A | 880W | 7.5A | 2.2 kW |
| GV-U6n | 6A (at 8 kHz) | 1.75 kW | 15A (at 8 kHz) | 4.4 kW |
| GV-U12n | 12A (at 8 kHz) | 3.5 kW | 30A (at 8 kHz) | 8.8 kW |
| GV-H20n | 20A (3Ø input at 8 kHz) | 5.8 kW | 50A (3Ø input at 8 kHz) | 14.7 kW |
| GV-H40n | 40A (3Ø input at 8 kHz) | 11.8 kW | 100A (3Ø input at 8 kHz) | 29.4 kW |

| Connector: | GV-L3/U3/U6/U12/H20: | GV-H40: |
|--------------------|--------------------------------|---------------------------------------|
| Drive terminals: | #8 (M4) screw terminals | #10 (M5) screw terminals |
| Mating terminals: | spade fork, 0.325" max. width | ring terminal, 0.25" I.D., 0.50" O.D. |
| Tightening torque: | 20 in-lbs nom., 24 in-lbs max. | 20 in-lbs nom., 24 in-lbs max. |

Amplifier

| | | | |
|-------|------------------------|--------------------|----------|
| Type: | GV-L3n: | 40 kHz PWM; | 3 phases |
| | GV-U3n: | 8 kHz PWM; | 3 phases |
| | GV-U6n/U12n/H20n/H40n: | 8, 16, 20 kHz PWM; | 3 phases |

Performance

Accuracy: ±1 encoder count; encoder dependent

Environmental Specifications

| | | | |
|-------------------------------|------------------------------|--|--|
| | | GV-L3n; GV-U3n/U6n/U12n; GV-H20n (with < 25W regen); GV-H40n | GV-H20n (with <100W regen) |
| Operating Temperature: | Still Air: | 45°C (113°F) | 35°C (95°F) |
| | Moving air: | 50°C (122°F) | 40°C (104°F) |
| | Minimum: | 0°C (32°F) | 0°C (32°F) |
| Storage Temperature: | -40°C – 85°C (-40°F – 185°F) | | |
| Humidity: | 0 – 95%, non-condensing | | |
| Shock: | 15g, 11msec half sine | | |
| Vibration: | 10 – 2000 Hz at 2g | | |

Standards

| | | |
|-------------------|---|---|
| UL, cUL | 508C | |
| CE for LVD | 72/23/EEC | |
| | BS EN61010-1:1993/A2:1995 (ie includes 1995 amendment AMD 8961) | |
| | Safety requirements for electrical equipment for measurement, control, and laboratory use | Part 1. General requirements |
| CE for EMC | 89/336/EEC | |
| | BS EN61800-3: 1997 | Adjustable speed electric power drive systems Part 3. EMC product standard including specific test methods. |
| | IEC 61800-3: 1996 | Adjustable speed electric power drive systems Part 3. EMC product standard including specific test methods. |

Interface/Communication

| | |
|-------------------|--|
| Connector: | |
| Drive connector: | 9 pin D-subminiature plug. |
| Mating connector: | 9 pin D-subminiature receptacle |
| RS-232: | RS-485*: |
| Rx, Tx, Gnd | 4-wire plus ground (Rx+, Rx-, Tx+, Tx-, Gnd) |
| 9600 baud | 9600 baud |
| 8 data bits | 8 data bits |
| 1 stop bit | 1 stop bit |
| no parity | no parity |
| full duplex | full duplex |
| | *twisted pair cabling recommended (e.g. Belden 9842) |

Weight

| Drive | Weight <i>pounds (kg)</i> |
|--------------|-------------------------------------|
| GV-L3n: | 4.2 (1.9) |
| GV-U3n: | 4.2 (1.9) |
| GV-U6n: | 4.9 (2.2) |
| GV-U12n: | 4.9 (2.2) |
| GV-H20n: | 8.9 (4.0) |
| GV-H40n: | 15.8 (7.2) |

Inputs and Outputs

This section describes all inputs and outputs (I/O) located on the 50 pin DRIVE I/O connector. Not all are required for your system to operate. The next drawing summarizes which are required, and which are optional.

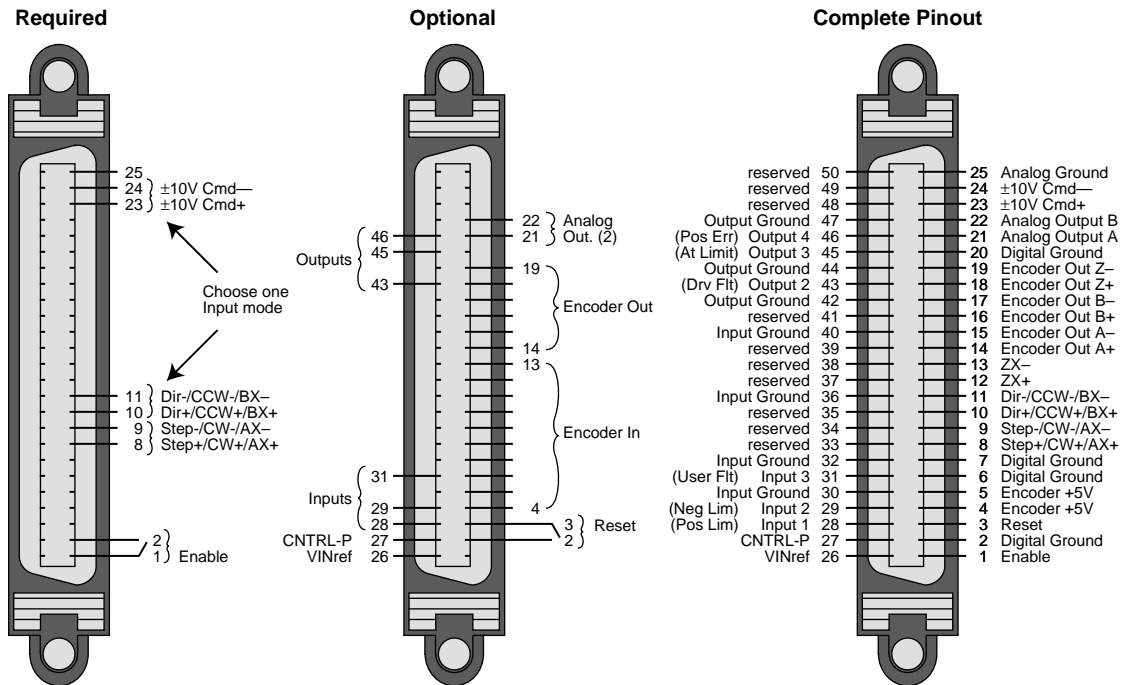

Drive I/O Connector

Connector Specifications:

| | Gemini Drive: | Mating Connector* (not provided; see note): |
|------------------|----------------------|--|
| Manufacturer: | AMP | AMP |
| Connector Type: | CHAMP .050 Series II | CHAMP .050 Series II |
| AMP Part Number: | 2-178238-7 | 2-175677-7 |
| Wire Gauge: | not applicable | use 28 AWG (0.08 mm ²) |

* Note: Mating connectors are not provided with Gemini drives; Compumotor cables are available with mating connectors attached. If you make your own cables, you must use a "jack screw" style fastener, not "spring clip" style. The mating connector listed above is an insulation displacement connector (IDC), intended for use with molded cables.

Soldercup Connector

The soldercup connector and plastic screw lock backshell listed below will fit onto the Gemini's DRIVE I/O connector. Because the backshell is plastic, it should not be used in CE applications.

| | Soldercup Connector | Screw Lock Backshell |
|-----------------|---------------------|----------------------|
| Connector Type: | Soldercup Connector | Screw Lock Backshell |
| Manufacturer: | 3M | 3M |
| 3M Part Number: | 10150-3000VE | 10350-52A0-008 |

Command Input (required)

The Gemini servo drive can accept several types of command input signals. Use the DMODE command to configure your drive to accept either $\pm 10V$ or a pulse input (step/direction, clockwise/counterclockwise, or encoder).

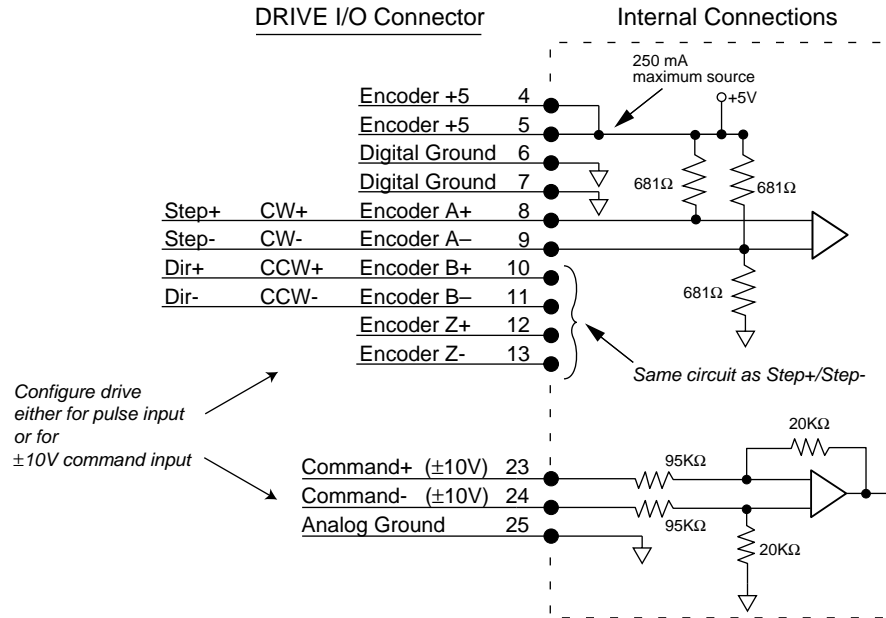

Command Inputs

If you use $\pm 10V$ command input signals, follow these instructions:

Connection Instructions for $\pm 10V$ Command Inputs

1. Connect COMMAND+ to pin 23.
2. Connect COMMAND- to pin 24.
3. Connect your controller's analog ground reference to pin 25.
4. If you use a Compumotor 6K Controller, use the analog command cable, not the step and direction command cable. See *Cable Specifications* later in this appendix for part numbers.

If you use a pulse source to generate step/direction, CW/CCW or encoder tracking signals, note that the drive's pulse inputs use differential receivers without opto-couplers. For best performance, follow these instructions:

Connection Instructions for Pulse Inputs

1. Connect your control's logic ground to the Gemini's ground, pin 6 or 7. This connection ensures that the signals stay within the common mode range of the differential receivers, and must not be omitted.
2. If you use a Compumotor 6K Controller, use the step and direction command cable, not the analog command cable. See *Cable Specifications* later in this appendix for part numbers.

Specifications for Pulse Inputs:

| | Step Pulse: | Encoder: |
|--------------------------------|-------------|------------------------|
| Maximum Input Pulse Frequency: | 2 MHz | 2 MHz (pre-quadrature) |
| Minimum Input Pulse Width: | 300 ns | 300 ns |

Enable Input (required)

To enable the drive and energize the motor, you must connect the enable input (pin 1) to digital ground (pin 2). The next drawing shows the internal circuit.

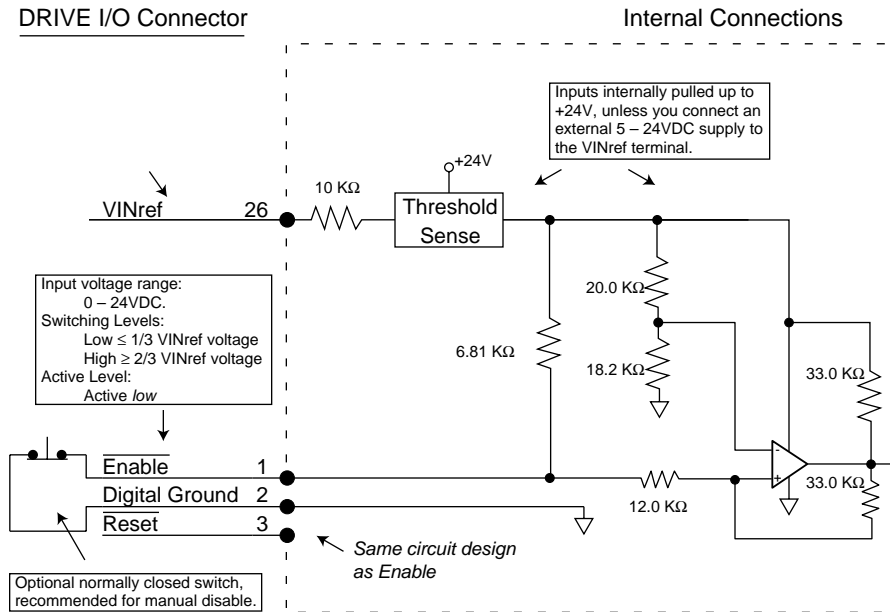

Enable Input and Reset Input

Reset Input (optional)

The reset and enable inputs use the same circuit design, as the drawing above indicates.

To reset the drive, temporarily connect the reset input (pin 3) to digital ground (pin 2). Reset begins when pin 3 is grounded. The drive will begin its power up sequence upon disconnection of pin 3 from ground.

VINref – Voltage Input Reference (optional)

Use VINref (pin 26) to set the input reference voltage for the enable, reset, and digital inputs.

It is not necessary for you to make connections to VINref. If you connect nothing, then the enable, reset, and inputs are internally pulled up to +24VDC. This is the factory default condition.

If you connect an external 5 – 24VDC power supply to VINref, then the input switching thresholds become:

$$\text{Low} \leq 1/3 * \text{VINref}$$

$$\text{High} \geq 2/3 * \text{VINref}$$

(Default:, with VINref at internal +24VDC: Low < 8V; High > 16V)

Digital Inputs (optional)

The Gemini drive has three digital inputs. Their functions are:

| | |
|---------|----------------------|
| Input 1 | Positive Limit Input |
| Input 2 | Negative Limit Input |
| Input 3 | User Fault Input |

By default, these are +24VDC sourcing inputs. You can use VINref (pin 26) to change the switching voltage level. You can also use CNTRL-P (pin 27) to change the inputs from sourcing to sinking inputs. All connections are shown in the next drawing.

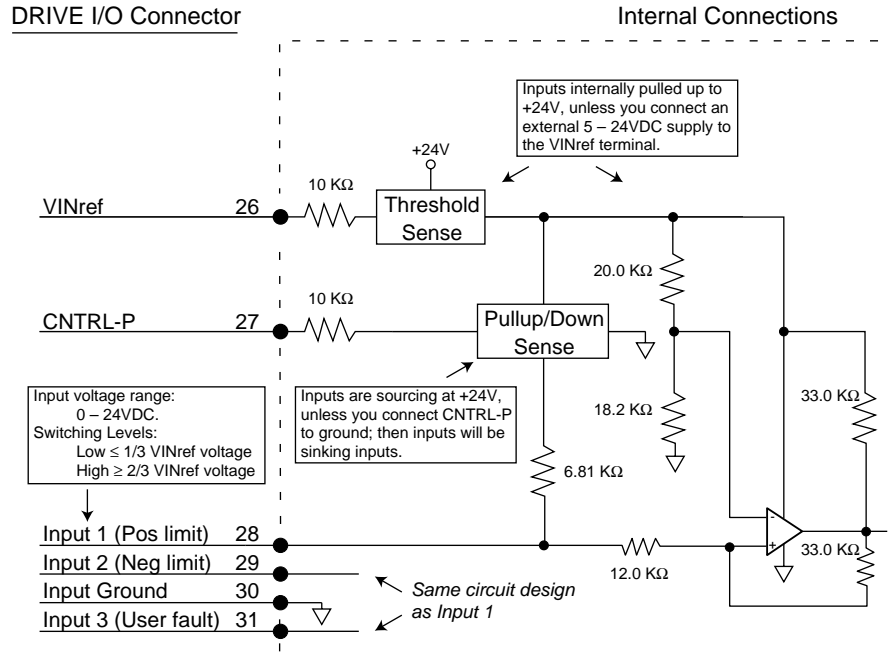

Inputs

You can use the INLVL and INDEB commands to configure the inputs as active high or active low, and to set the debounce time, respectively.

CNTRL-P – Reference for Digital Inputs (optional)

Use CNTRL-P (pin 27) to change the digital inputs from sourcing inputs to sinking inputs.

It is not necessary for you to make any connections to CNTRL-P. If you connect nothing, then the inputs are internally pulled up to VINref. If sourcing inputs are appropriate for your application, then make no connections to CNTRL-P.

If you connect CNTRL-P (pin 27) to digital ground (pin 30), then the inputs will become sinking inputs, and will sink current.

Digital Outputs (optional)

The Gemini drive has three digital outputs. Their functions are:

- Output 2* Drive Fault Output
- Output 3* At Limit
- Output 4* Position Error Output

* For compatibility with other Compumotor products, the outputs are numbered 2, 3 and 4, rather than 1, 2 and 3.

All connections are shown in the next drawing.

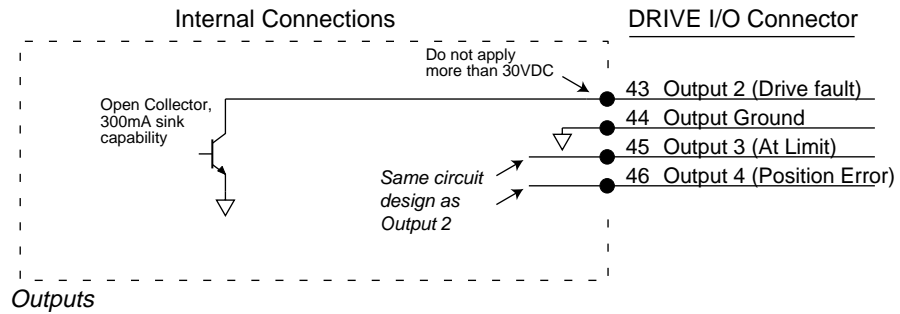

You can use the OUTLVL command to configure each of the outputs as active high or active low.

Encoder Output (optional)

Pins 14 – 19 are encoder outputs.

Encoder Output Specifications:

| | |
|----------------------------|---|
| Default Resolution: | Quadrature outputs 4000 counts per revolution, post quadrature |
| Clockwise Rotation: | Channel A leads Channel B |
| Counterclockwise Rotation: | Channel B leads Channel A |

The encoder outputs operate in one of two modes:

Pseudo Encoder Mode:

Output Channels A and B are derived from position information from the load feedback device (e.g. encoder or resolver). The outputs are *not* based on calculated or commanded position. Pseudo encoder mode is the default mode, unless all conditions listed in the next paragraph are satisfied. There is no Channel Z output in pseudo encoder mode.

Pass Through Encoder Mode:

When the following three conditions are satisfied, then Channels A, B, and Z are "passed through" the drive, from the feedback device (e.g. encoder or resolver) to the encoder outputs.

Required Conditions for Pass Through Encoder Mode

1. ERES and ORES values are equal.
2. Drive serial number is greater than 99072100143
3. Gemini Operating System version is 1.01 or greater.

If any one of these conditions is not satisfied, then the outputs will operate in pseudo encoder mode.

The encoder output circuit is shown in the next drawing.

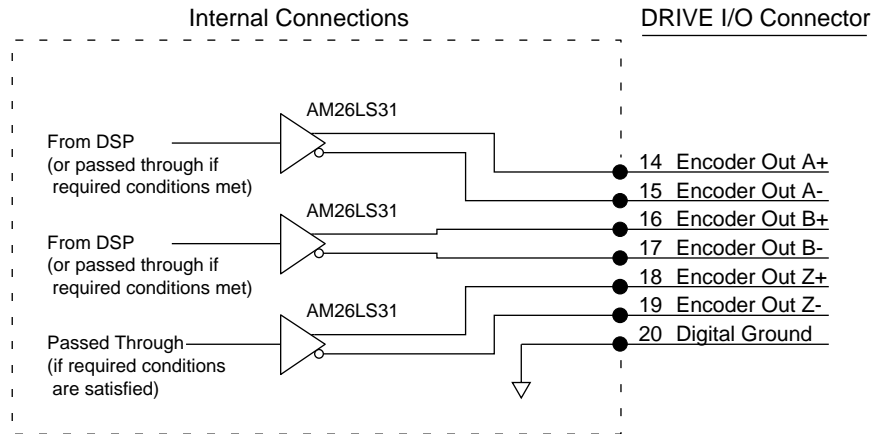

Encoder Outputs

You can use the ORES command to configure the encoder outputs.

Analog Monitor (optional)

Two analog monitor outputs are available on pins 21 and 22. Use pin 25 as a ground reference for these monitors.

Analog Monitor Specifications:

- Maximum Output: $\pm 10V$ (scalable)
- Resolution: 8 bits peak to peak (for full scale signal)

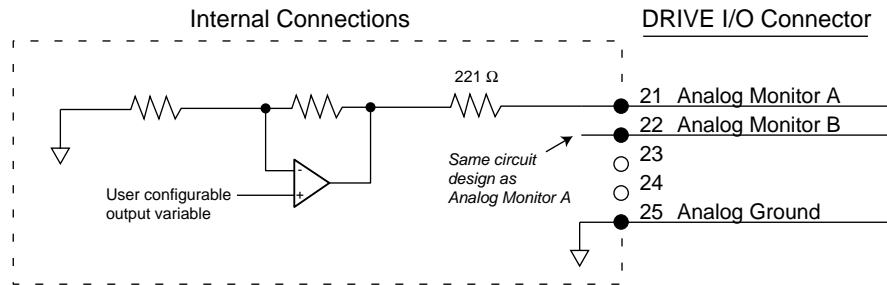

Analog Monitors

You can configure the analog outputs to monitor many different variables, such as current, velocity, temperature, etc. You can also scale the outputs. See the DMON commands in *Chapter 3 Configuration* and the *Gemini Programmer's Reference* for more information.



WARNING



Do not use Analog Monitors as control signals. Because of offsets, limited resolution and accuracy, use the analog monitor outputs only for oscilloscope monitoring.

Feedback Devices

This section describes inputs for encoder feedback, resolver feedback, motor thermal switch, and Hall effects located on the drive's 26 pin MOTOR FEEDBACK connector. The next drawing shows the pinout of the connector.

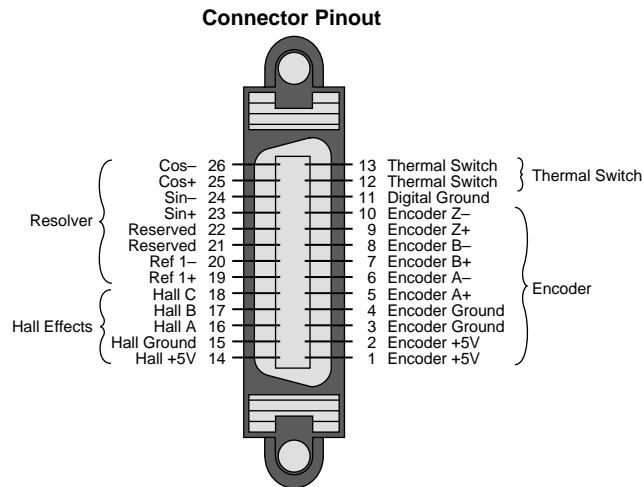

Motor Feedback Connector

Connector Specifications:

| | Gemini Drive: | Mating Connector* (not provided; see note): |
|------------------|----------------------|--|
| Manufacturer: | AMP | AMP- |
| Connector Model: | CHAMP .050 Series II | CHAMP .050 Series II |
| AMP Part Number: | 2-178238-4 | 2-175677-4 |
| Wire Gauge: | not applicable | use 28 AWG (0.08 mm ²) |

* Note: Mating connectors are not provided with Gemini drives; Compumotor cables are available with mating connectors attached. If you make your own cables, you must use a "jack screw" style fastener, not "spring clip" style. The mating connector listed above is an insulation displacement connector (IDC), intended for use with molded cables.

Soldercup Connector

The soldercup connector and plastic screw lock backshell listed below will fit onto the Gemini's MOTOR FEEDBACK connector. Because the backshell is plastic, it should not be used in CE applications.

| | | |
|-----------------|---------------------|----------------------|
| Connector Type: | Soldercup Connector | Screw Lock Backshell |
| Manufacturer: | 3M | 3M |
| 3M Part Number: | 10126-3000VE | 10326-52A0-008 |

Encoder

If you use a motor with encoder feedback, connect your encoder to pins 1 – 10, as shown in the figure below.

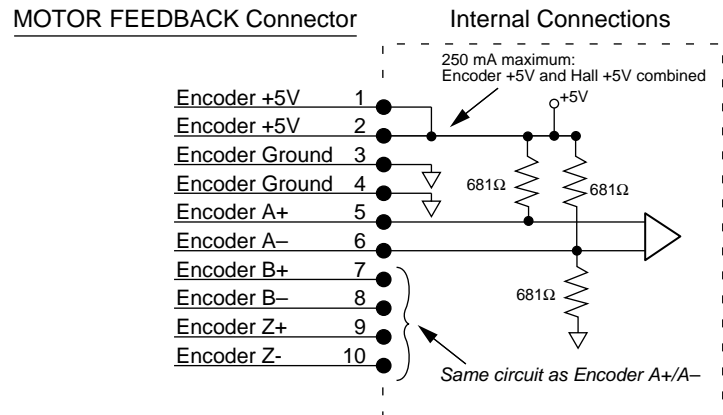

Encoder Input Connections

Because the wire used in many encoder cables is very thin, we provide two pins for encoder +5VDC (pins 1 and 2) and for encoder ground (pins 3 and 4). Connect two wires in your encoder cable to the +5VDC pins, and connect two wires to the encoder ground pins. We recommend that you splice each pair of wires to a larger diameter wire, as shown in the next drawing.

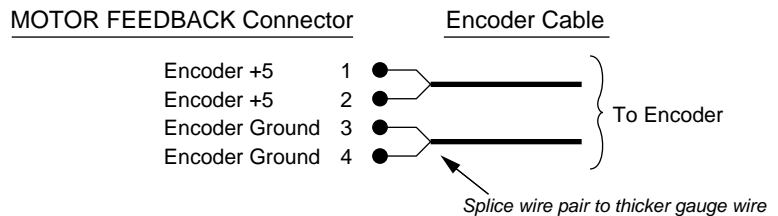

Splicing Wires Together

Splicing to a larger wire provides more wire for current conduction, minimizing voltage drop at the encoder. (Gemini motor feedback cables use this technique.)

Resolver

If you use a motor with resolver feedback, connect the resolver to pins 19 – 26, as shown in the figure below.

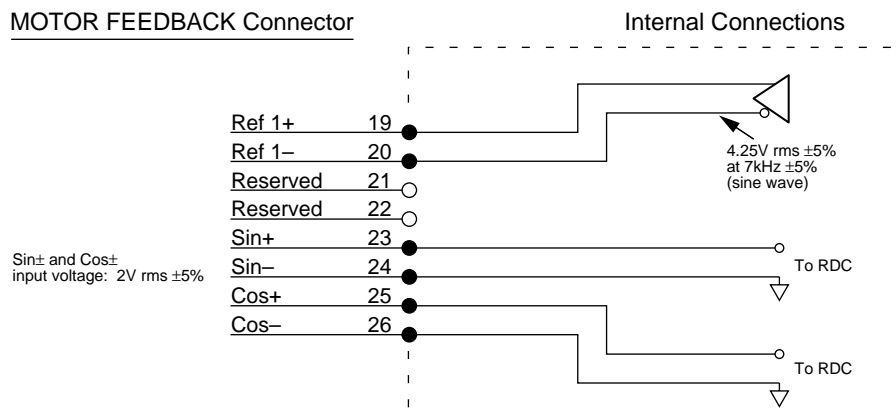

Resolver Input Connections

Motor Thermal Switch Connections (optional)

Connect your motor's thermal switch wires to pins 12 and 13 on the MOTOR FEEDBACK connector.

The drive checks for electrical continuity between pins 12 and 13. This continuity is usually provided by a normally-closed thermal switch mounted on the motor. If the motor overheats and the thermal switch opens, the loss of continuity triggers protection circuitry in the Gemini drive. The drive will turn off power output to the motor, illuminate the left LED red, and set the motor fault and drive fault bits. You can monitor the fault bits with the TAS and TASX commands.

To resume operations after the motor cools and its thermal switch closes, cycle power or issue a DRIVE1 command.

If your motor does not have a thermal switch, short pins 12 and 13 together. The drive will experience a motor fault if neither a thermal switch nor a jumper wire is attached to pins 12 and 13.

Hall Effects

Connect your motor's Hall effect wires to pins 14 – 18 on the MOTOR FEEDBACK connector.

The Gemini GV drive is designed to be used with motors that have single-ended, open collector Hall outputs. Internally, the drive pulls these signals up to +5V. The Hall effect circuit is shown below.

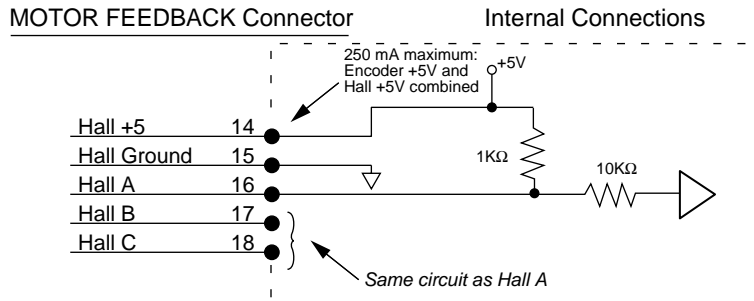

Hall Effect Connections

The Gemini drive uses the Hall effect inputs to synchronize the encoder with the motor's internal magnets at the start of motion. Initial commutation is trapezoidal; once the drive establishes synchronization it changes to sinusoidal commutation based on encoder position.

Dimensions

Drive Dimensions

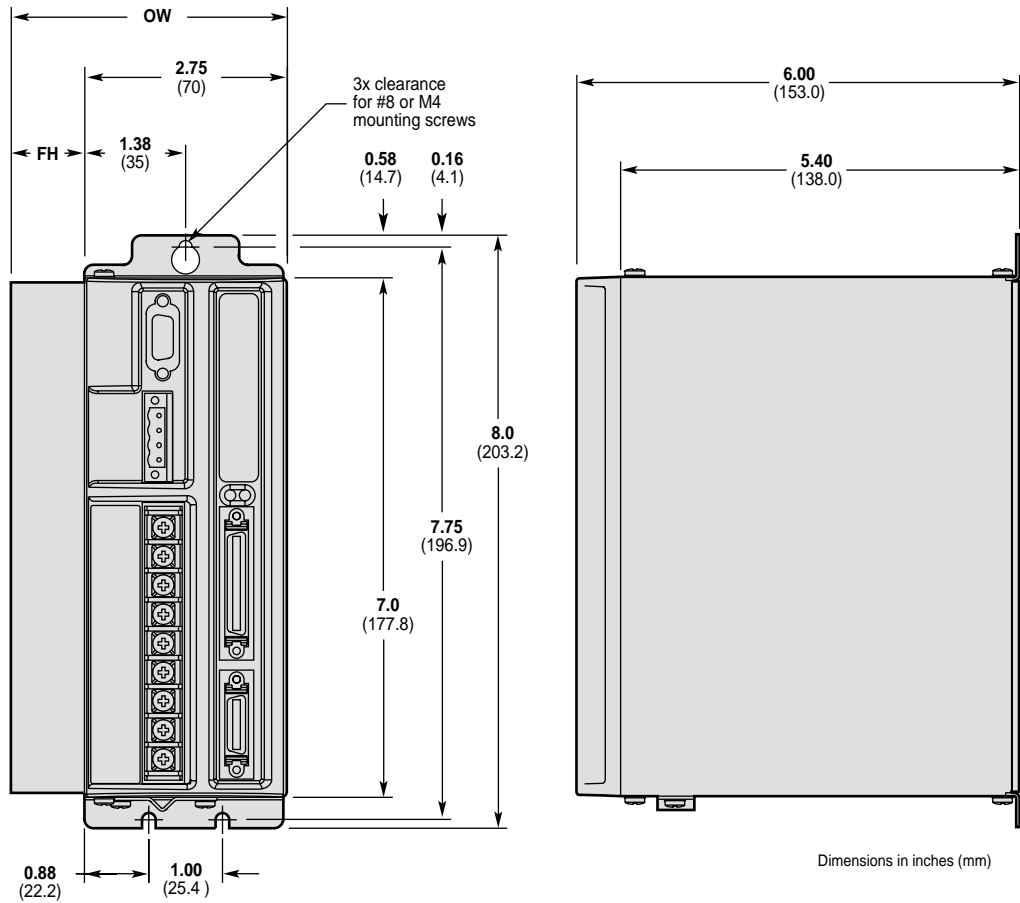

Dimensions in inches (mm)

| Product | OW Overall Width inches (mm) | FH Fin Height inches (mm) |
|---------|------------------------------------|---------------------------------|
| GV-L3n | 3.13 (79.4) | 0.38 (9.5) |
| GV-U3n | 3.13 (79.4) | 0.38 (9.5) |
| GV-U6n | 3.75 (95.3) | 1.00 (25.4) |
| GV-U12n | 3.75 (95.3) | 1.00 (25.4) |

Dimensions (Shorter Enclosure)

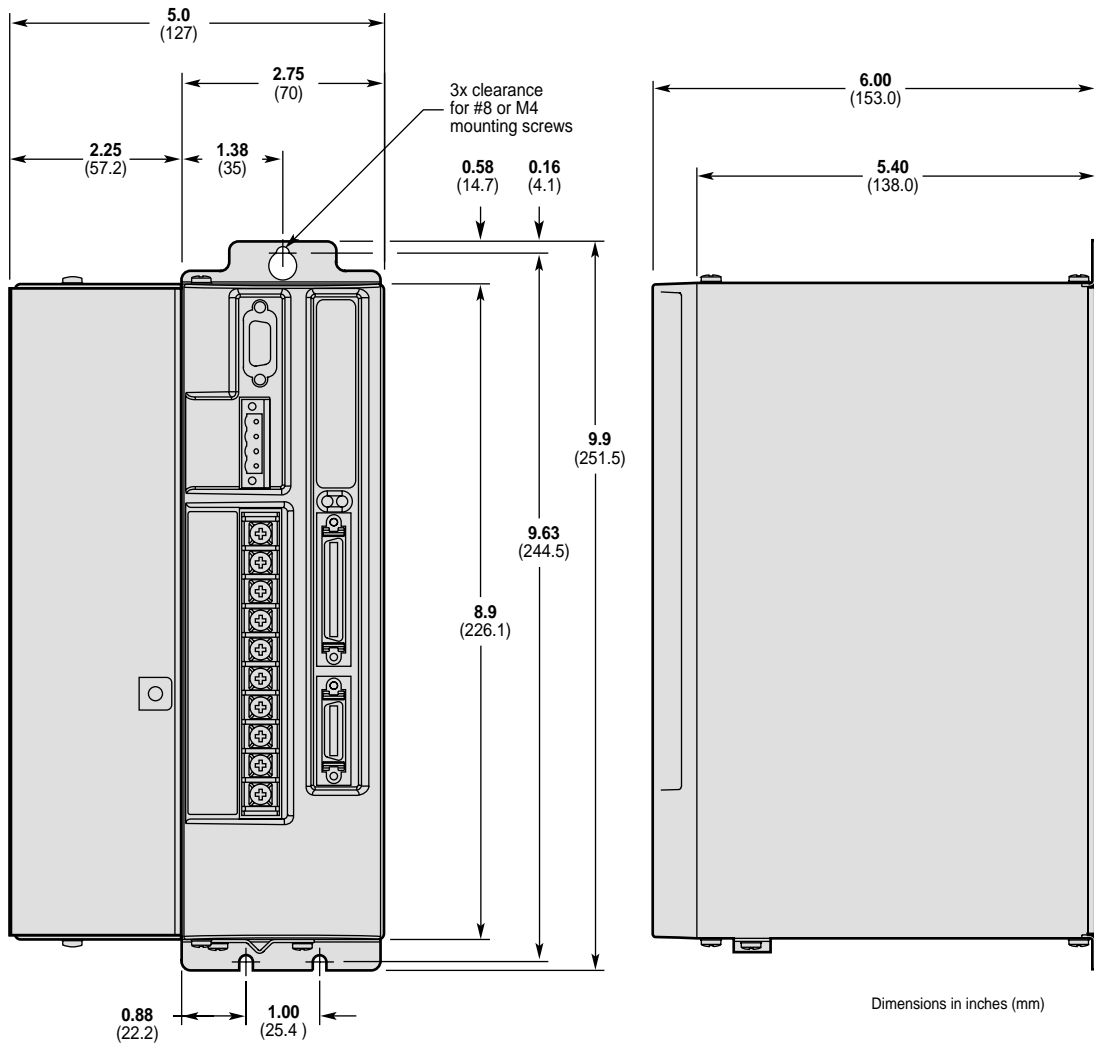

Dimensions – GV-H20n

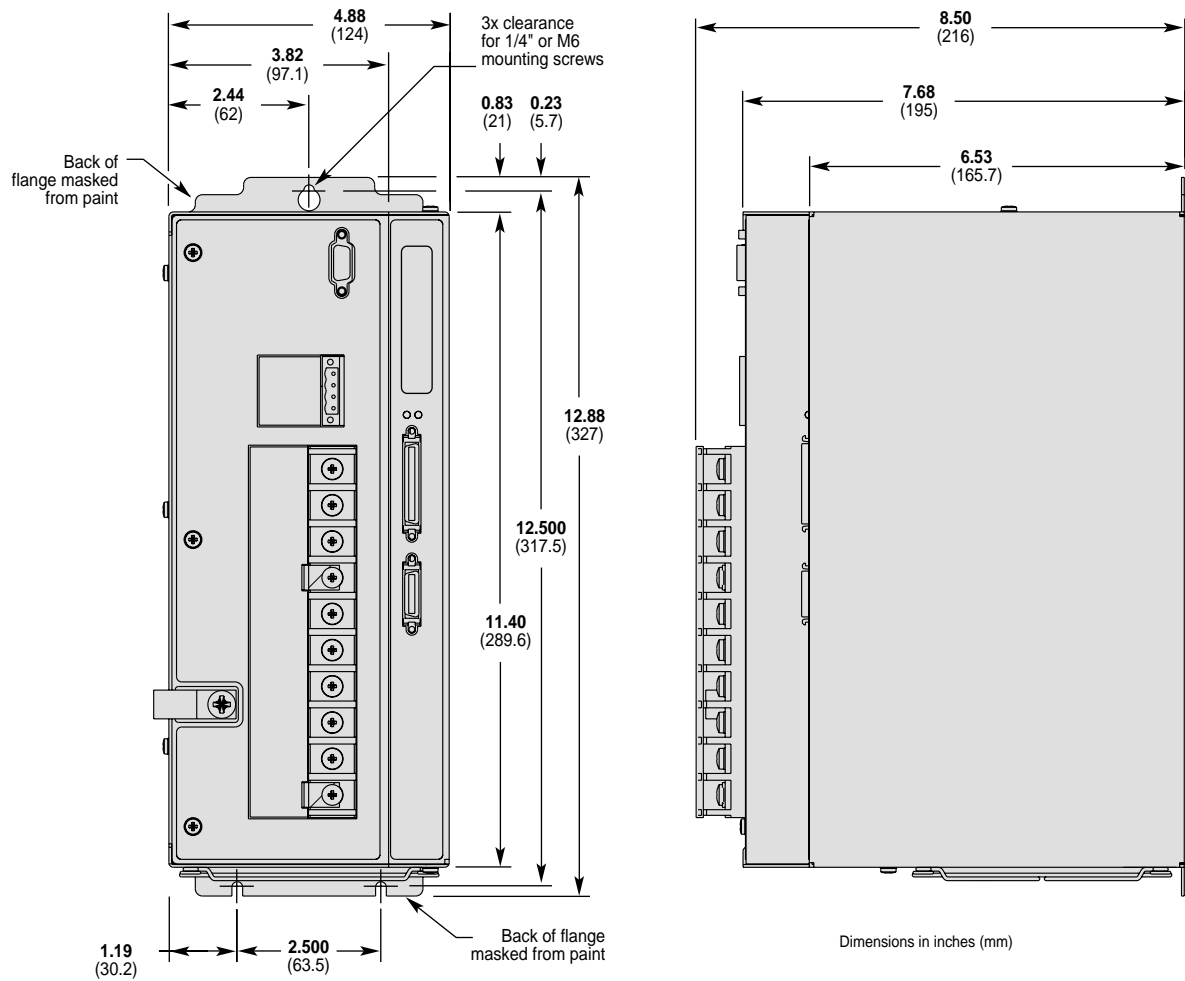

Dimensions – GV-H40n

Drive Mounting

The Gemini drive is a vented product. Mount it under an overhang to prevent material spilling into the drive.

Panel Layout Dimensions

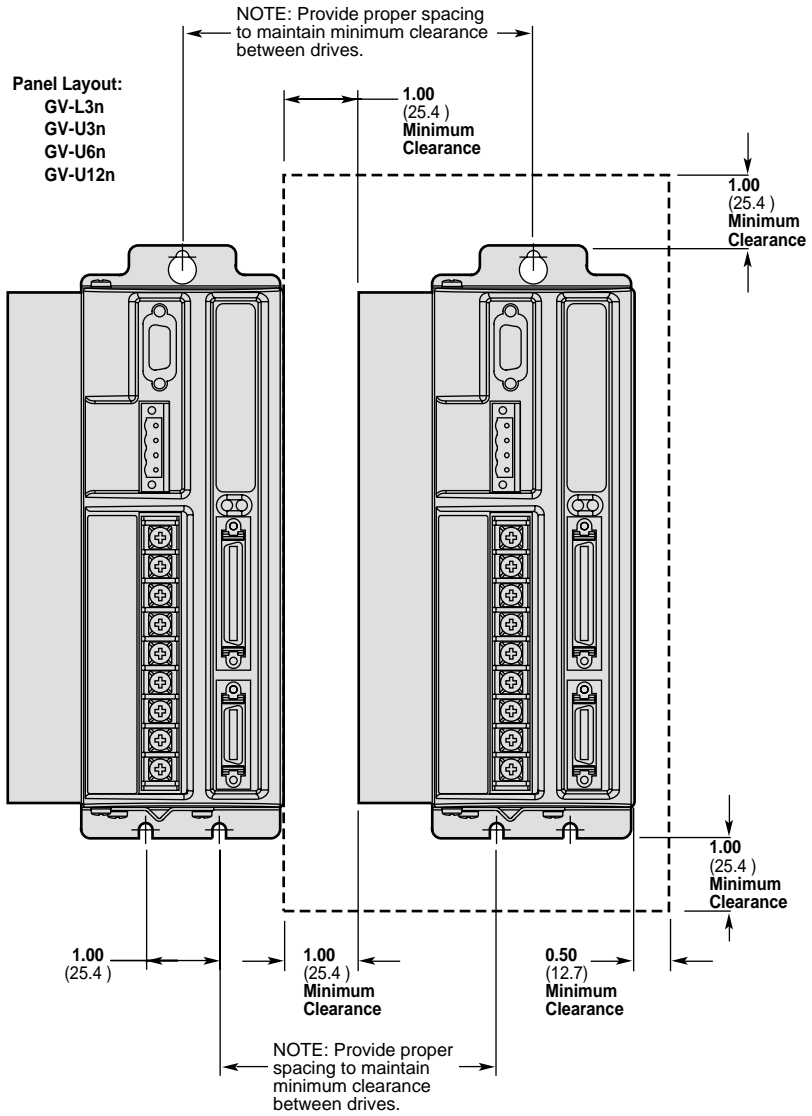

Panel Layout Dimensions – GV-L3n, GV-U3n/6n/12n

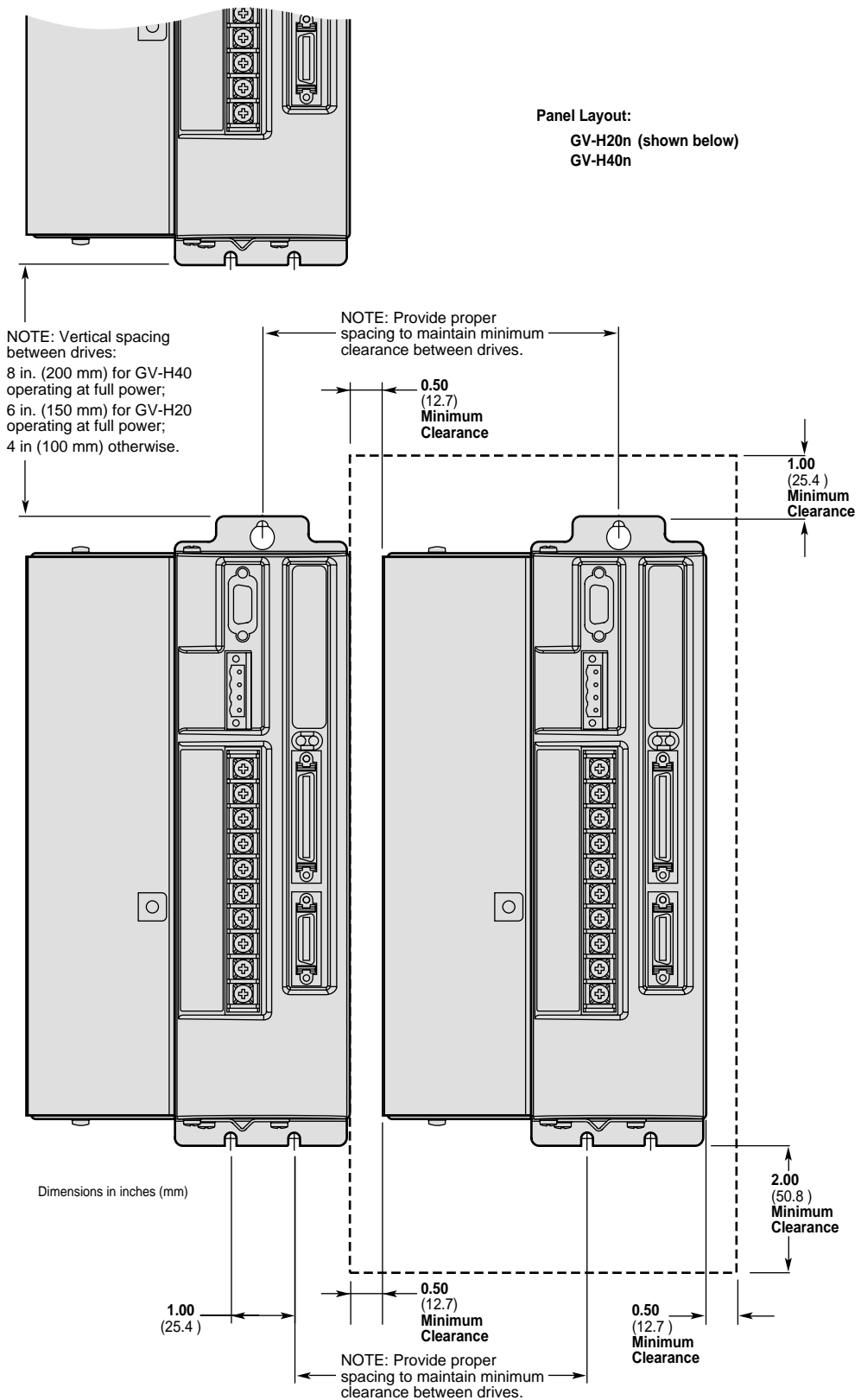

Panel Layout Dimensions – GV-H20n and GV6-H40n

Protective Circuits

Short Circuit Protection

The Gemini drive has an internal circuit that protects it from short circuits between one motor terminal to another (phase to phase), or from any motor terminal to earth. A short circuit fault is a latched fault.

| | |
|--------------------------------|---|
| Short circuit fault caused by: | Phase to phase short circuit Phase to earth short circuit |
| Results of Fault: | Power to motor is turned OFF LEDs: Left = illuminated RED; Right = off Fault output is activated Latched fault |

Inrush Current Protection

The Gemini drive has internal circuitry that protects it from high inrush current when power is initially applied to the drive. The circuitry works automatically.

| Drive | Inrush Current Limiter (ohms): | Current limiter bypassed with shorting relay: |
|---------|--------------------------------|---|
| GV-L3n | 5Ω | yes |
| GV-U3n | 10Ω | yes |
| GV-U6n | 10Ω | yes |
| GV-U12n | 10Ω | yes |
| GV-H20n | 10Ω | yes |
| GV-H40n | 20Ω | yes |

The shorting relay removes the inrush current limiter after drive startup. This allows maximum bus voltage during high acceleration/peak torque/maximum speed applications.

Inrush current is temperature dependent:

| Ambient Temperature: | Inrush Current Limit: |
|----------------------|-----------------------|
| 25°C (77°F) | less than 35 amps |
| 50°C (122°F) | less than 70 amps |

Drive Overtemperature Protection

The Gemini drive's overtemperature circuit monitors the drive's internal temperature sensors. If the sensors exceed the threshold temperature, the drive issues an overtemperature fault.

| | |
|------------------------|---|
| Threshold Temperature: | All drives except GV-H20n: 80°C (176°F) GV-H20n: 90°C (194°F) |
| Results of Fault: | Power to motor is turned OFF LEDs: Left = illuminated RED; Right = off Fault output is activated Latched fault |

Motor Overtemperature Protection

The Gemini drive has two motor overtemperature circuits:

| | |
|----------------------|--|
| Hardware Switch: | a thermal switch is embedded in Compumotor motor windings |
| P_t Thermal Model: | the drive's internal operating software predicts motor winding temperature, based on motor parameters. |

Undervoltage Protection

The Gemini drive's undervoltage protection circuit monitors AC input voltage. If the voltage falls below 75VAC while the drive is operating (85VAC for GV-H20), the drive issues an undervoltage fault and turns off power to the motor.

Undervoltage protection has the following features:

| | |
|--------------------|---|
| Threshold Voltage: | Voltage falling below 75VAC trips fault (85VAC for GV-H20n) |
| Results of Fault: | Power to motor is turned OFF LEDs: Left = illuminated RED; Right = off Fault output is activated Latched fault |

Overvoltage Protection

The Gemini drive's overvoltage circuit protects the drive from excessive regeneration. If the voltage on the motor output terminals rises above the threshold voltage, the drive disables its output terminals, and the motor will freewheel.

| | |
|--------------------|---|
| Threshold Voltage: | GV-L3n: 212VDC GV-U3n/6n/12n/H20n/H40n: 410VDC |
| Results of Fault: | Power to motor is turned OFF LEDs: Left = illuminated RED; Right = off Fault output is activated Latched fault |



CAUTION



Overvoltage protection monitors only the motor output terminals (DC motor bus). It does not protect against an overvoltage on the AC input terminals.

Current Foldback

The GV drive's current foldback circuit helps to protect the motor from damage due to prolonged high currents.

If your drive is operating above its continuous rating, use the figure below to predict the number of seconds until foldback will occur. For example, the figure shows that at the drive's peak current rating (250% of continuous), foldback will occur after six seconds.

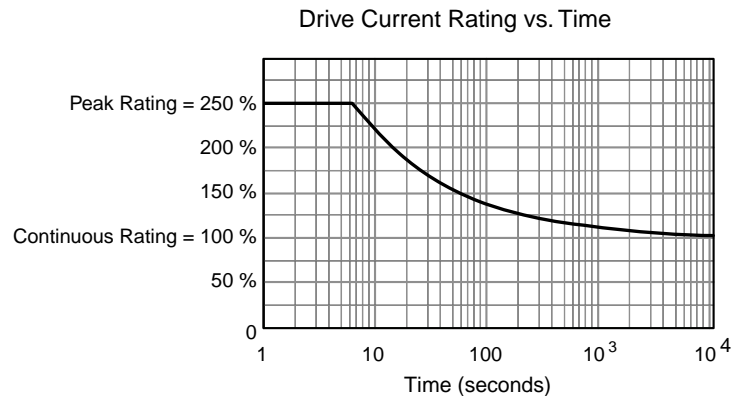

Time Until Foldback

See *Chapter 3 Configuration* for more information on how to configure the current foldback circuit to protect your motor.

Cable Specifications

This section contains specifications for Compumotor cables and cabling accessories you can use with Gemini drives.

CE Cables

Many Compumotor cables are *CE Cables*. If installed according to instructions in *Appendix C – Regulatory Compliance: UL and CE*, these cables are designed to aid the user in gaining European Compliance, and are thus an integral part of a CE system solution. CE cables add RF screening and bonding to reduce emissions, and provide high integrity safety Earth bonding. They also help to reduce problems in high electrical noise environments.

Non-CE Cables

Compumotor also offers non-CE cables, for applications where CE compliance is not required, and where ambient electrical noise does not cause problems. Because these cables are either unshielded, or contain simple foil shielding terminated by a drain wire, they do not provide significant shielding of electrical noise at high frequencies.

To help you select the correct cables for your application, see Compumotor's Technical Bulletin *TB269: Proper Cable Selection – CE vs. Non-CE Gemini Applications*.

Analog Command Cable

If you operate the drive in torque or velocity mode, use this cable to connect the Gemini GV drive to a Compumotor 6K controller.

NOTE: If you use the Gemini GV drive in step and direction mode, use the step and direction command cable.

| | | |
|---------------|--------------------------|-------------------------|
| CE Cable: | Part Number 71-016987-10 | 10 ft. (3 m) in length |
| Non-CE Cable: | Part Number 71-019863-04 | 4 ft. (1.2 m) in length |

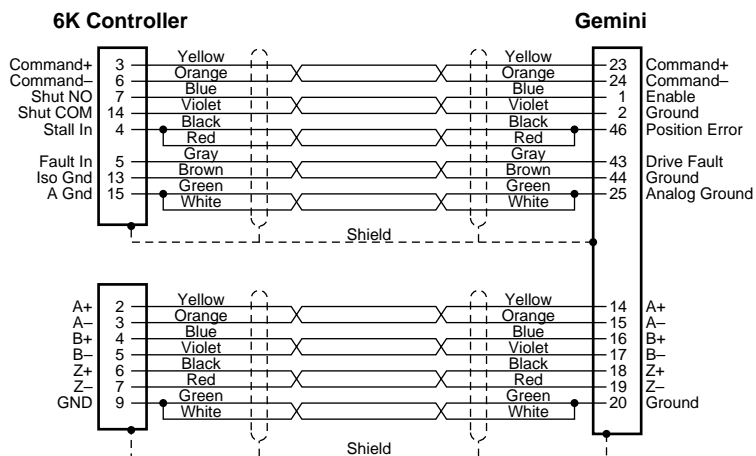

Cable – Analog Command (color code is for CE Cable)

Step and Direction Command Cable

If you operate the drive in step and direction (position) mode, use this cable to connect the Gemini drive to a Compumotor 6K controller

CE Cable: Part Number 71-016966-10 10 ft. (3 m) in length
 Non-CE Cable: Part Number 71-019862-04 4 ft. (1.2 m) in length

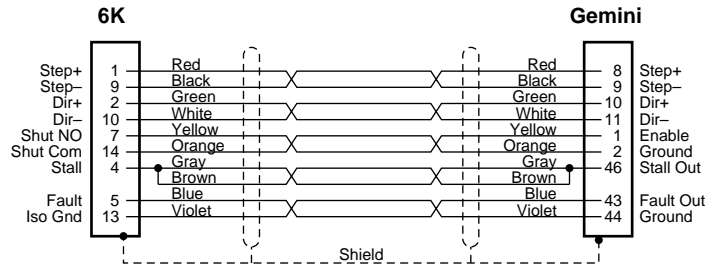

Cable – Step and Direction (color code is for CE Cable)

Gemini 50 Pin Connector to Flying Leads Cable

Use this cable to connect the Gemini drive's 50 pin connector to a Compumotor 6200, AT6n00, 6250, AT6n50 or non-Compumotor indexers/controllers.

NOTE: If using Compumotor 6000 Series *stepper* products, connect Gemini VINref (pin 26) to +5VDC, such as Gemini ENCODER +5 (pin 4 or 5). Do not connect Gemini VINref to any voltage higher than +5VDC. (This VINref connection is not necessary on 6000 Series *servo* products.)

CE Cable: Part Number 71-016943-10 10 ft. (3 m) in length
 Non-CE Cable: Part Number 71-019861-04 4 ft. (1.2 m) in length; and
 71-019861-10 10 ft. (3 m) in length

Compumotor 6200, AT6n00 Connections

The next drawing shows connections to a Compumotor 6200 or AT6n00 indexer.

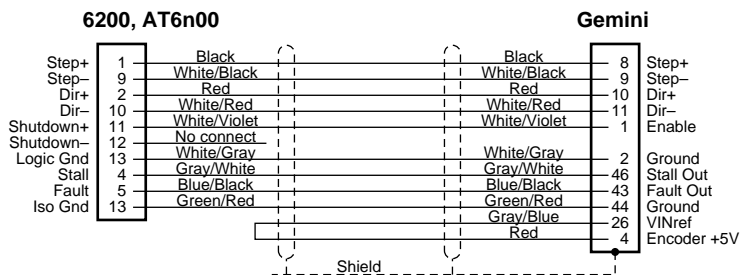

Cable – Flying Leads – 6200 Connections (color code is for CE Cable)

Compumotor 6250, AT6n50 Connections

The next drawing shows connections to a Compumotor 6250 or AT6n50 controller.

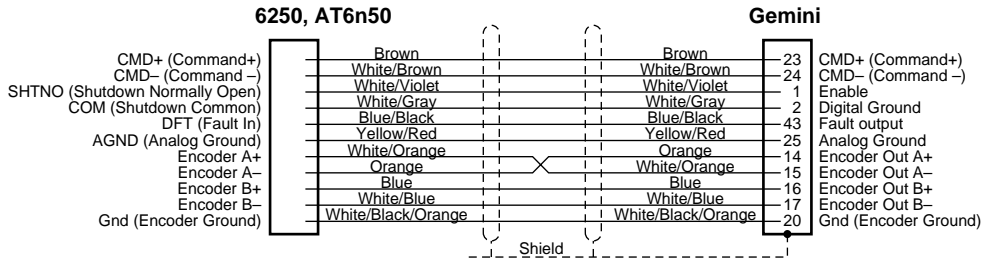

Cable – Flying Leads – 6250 Connections (color code is for CE Cable)

Flying Lead Cable – Color Code

The next drawing shows the color code for the 50 pin connector/flying lead cable. Note that the CE and non-CE cables have different color codes.

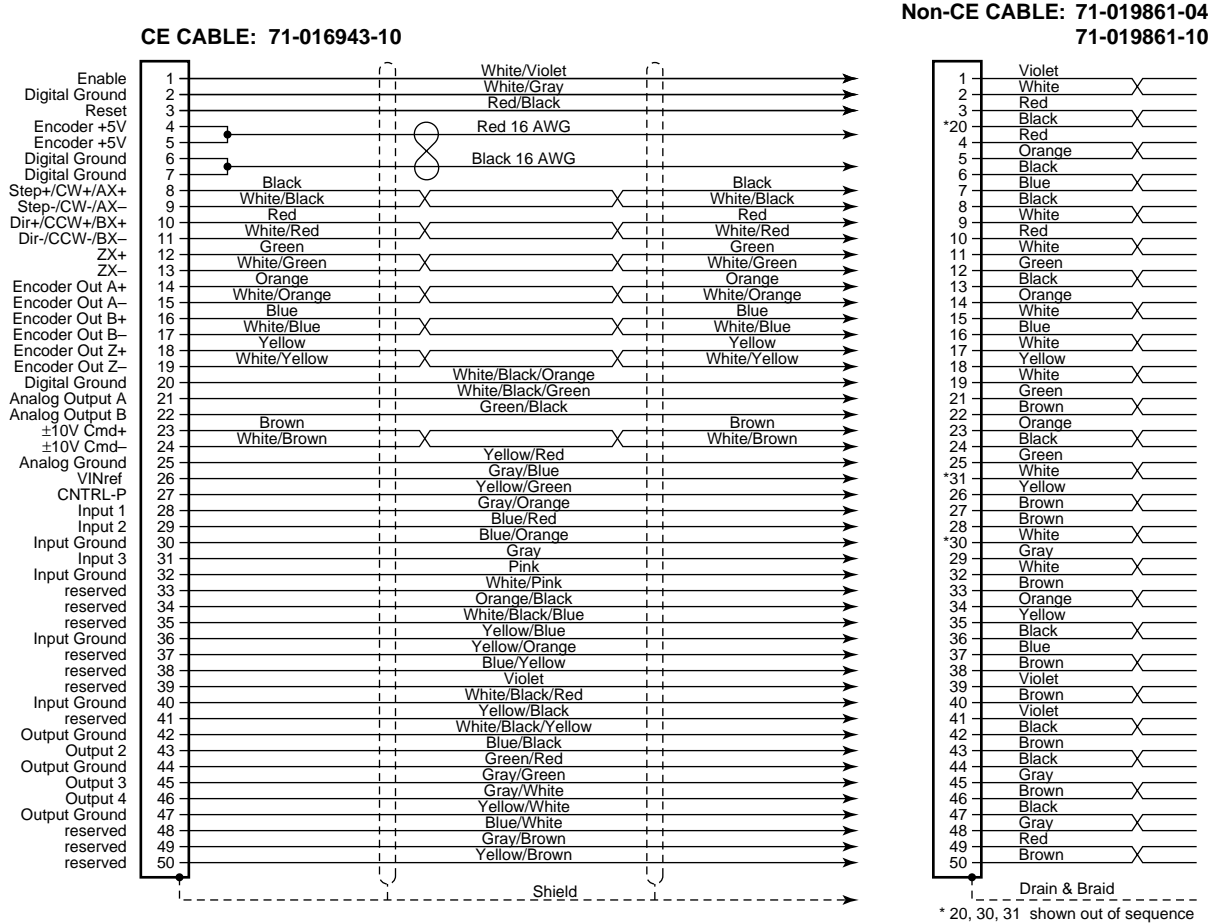

Cable – Flying Leads (color code for CE and non-CE cables)

Gemini 50 Pin Connector to 50 Pin D-Connector Cable

Use this cable to connect the Gemini drive's 50 pin DRIVE I/O connector to the 50 pin D-connector on the Gemini 50 pin breakout module (GEM-VM50).

CE Cable: Part Number 71-016945-03

This cable has the same pinout and color code as the CE version of the flying lead cable; instead of flying leads, it has a 50 pin D-connector on the end.

Gemini GEM-VM50 – 50 Pin Breakout Module

Use the 50 pin breakout module for access to individual terminals on the 50 pin connector. The GEM-VM50 includes the cable above.

| Description: | Part Number: |
|--|--------------|
| 50 pin Breakout Module (with Cable) | GEM-VM50 |
| 50 pin Breakout Module (without cable) | 01-016986-01 |

Null Modem Cable – 9 Pin D-Connector to 9 Pin D-Connector

Use this cable for RS-232 communications between the Gemini drive and a terminal. Note that this is not a "straight-through" cable; pins 2 and 3 are crossed, making it a "null-modem" cable.

CE Cable: Part Number 71-016939-10

Connector: 9 pin female D-subminiature connector on each end

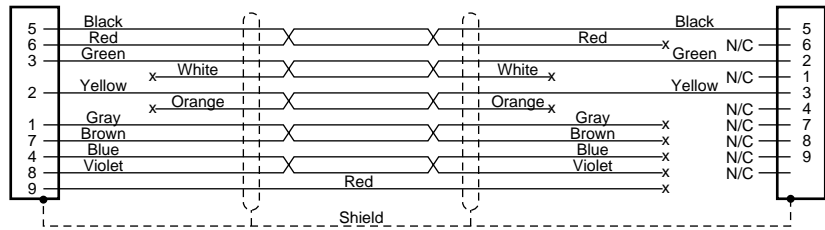

Cable – RS-232 Null Modem



Gemini GC-26 and GC-50 Connectors

Two breakout modules are available that connect directly to the Gemini's MOTOR FEEDBACK and DRIVE I/O connectors.

NOTE: These modules are recommended for system prototyping only—not for permanent installation.

| Description: | Part Number: |
|----------------------------------|--------------|
| 26 pin Connector/Breakout Module | GC-26 |
| 50 pin Connector/Breakout Module | GC-50 |

Dimensions are shown below.

CAUTION

Connect wires to the GC-26 and GC-50 *before* installing in the drive. This will avoid damage that may be caused by wiring the connector while attached to the drive.

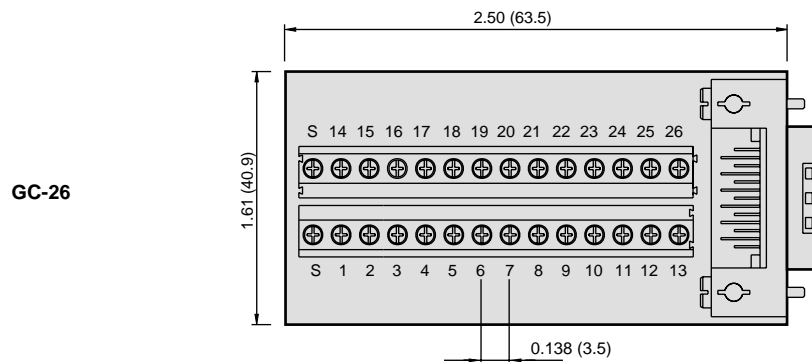
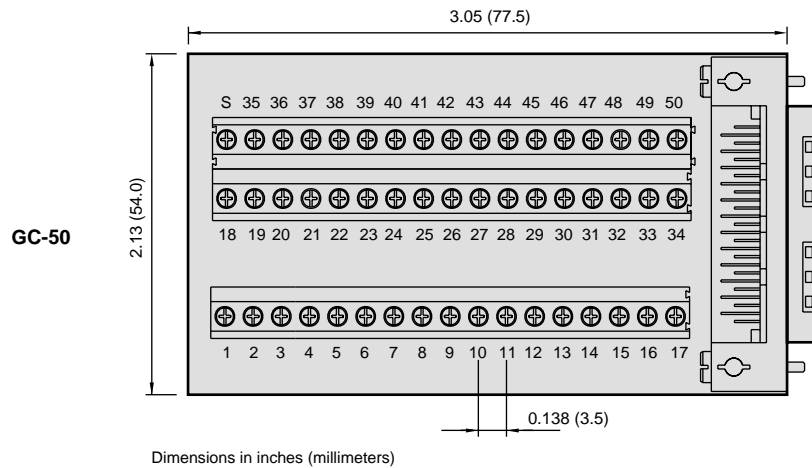

GC-26 and GC-50 Dimensions

Gemini 26 Pin Feedback Connector Kit

A cable connector backshell kit is available from Compumotor. The kit includes plug, cover, and all parts necessary to assemble the connector. It also includes spade lugs to install on the motor cable. The part number is:

GFB-KIT

The plug mates with the drive's 26 pin MOTOR FEEDBACK connector.